

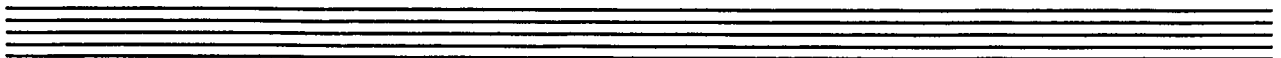

ATTENTION OWNERS

Thank you for purchasing the Kurzweil K1200 Pro 76. Your Pro 76 offers the same high-quality sounds and features as the 88-key K1200 Professional. The only difference is in the number of keys. Although this manual refers to the K1200 Professional, it also applies to the Pro 76, since the functions of both instruments are identical.

**Young Chang America
13336 Alondra Blvd.
Cerritos, CA 90701-2205
(310) 926-3200**



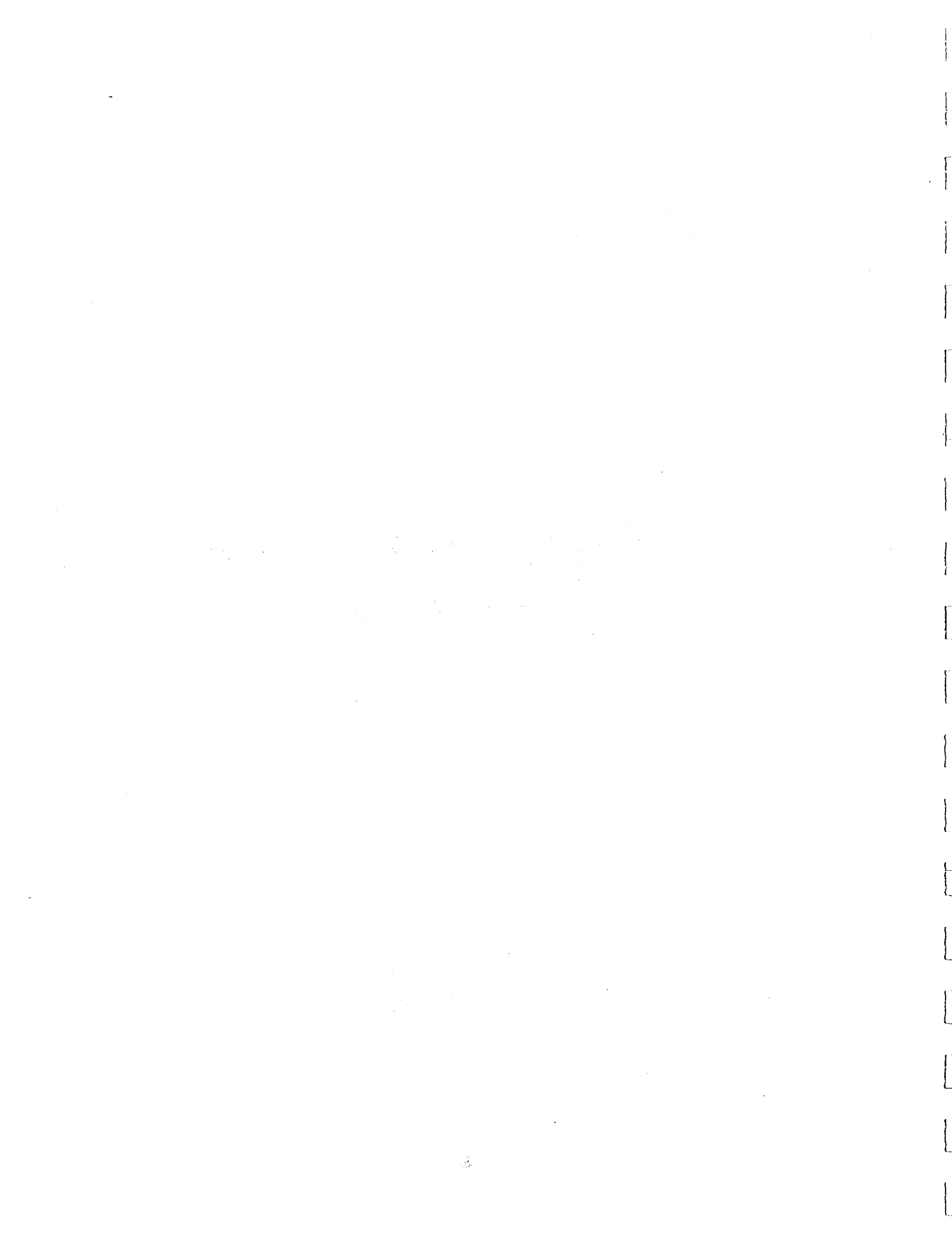

T A B L E O F C O N T E N T S

<i>Page</i>	<i>Section</i>
-------------	----------------

1	I. Introduction
2	1.1. About This Manual
2	1.2. Unpacking and Inspection
3	1.3. Summary of Precautions
3	1.4. Description of Features
3	1.4.1. The Kurzweil 1000 Series
4	1.4.2. K1200 Structure
5	1.4.3. Front Panel Controls & Display
7	1.4.4. Rear Panel Connectors
8	II. Connections
8	2.1. AC Power
10	2.2. Audio Outputs
10	2.2.1. Instrument Amplifiers
11	2.2.2. Stereo Systems
11	2.2.3. Mixing Consoles
12	III. Operation
12	3.1. Getting Started
12	3.1.1. Setting the Output Level
13	3.2. Automatic Demo
14	3.3. Exploring Programs
14	3.3.1. Selecting Programs By Number
14	3.3.2. Using the Bin Banks
16	3.4. PLAY Mode Performance Shortcuts
18	3.5. MIDI Operation
19	3.5.1. Typical MIDI Connections
20	3.6. MIDI Modes
20	3.6.1. Omni
20	3.6.2. Poly
20	3.6.3. Mult
21	3.7. Disabling and Deassigning Channels
22	3.8. MIDISCOPE
22	3.9. Resetting the K1200
23	3.9.1. Soft Reset
23	3.9.2. Hard Reset
23	3.10. Troubleshooting Reference
25	IV. Basic Editing
25	4.1. Introduction
25	4.1.1. Voice Structure in the 1000 Series

<i>Page</i>	<i>Section</i>
-------------	----------------

25	4.1.2. The Editing Process
28	4.1.3. Entering Edit Mode
28	4.1.4. The Compare Function
29	4.2. Creating Layers & Splits
29	4.2.1. Layered Programs
30	4.2.2. Split Programs
31	4.3. Using Compiled Effects
31	4.3.1. Selecting Effects
32	4.3.2. Modifying Effects
32	4.4. Naming & Saving Programs
32	4.4.1. Naming Programs
35	4.4.2. Saving Programs
36	4.5. Monophonic Output Setting
36	4.6. Advanced Program Editing

Part II—Programming Reference

37	V. Introduction
38	5.1. About This Manual
38	5.2. 1000 Series Objects
39	5.3. The Editing Menu System
40	5.4. About Control Sources
40	5.4.1. Control Source Configuration
40	5.4.2. Control Source Type
40	5.4.3. Descriptions of Control Sources
45	5.5. Reading The Next Sections
46	VI. The Master Menu
59	6.1. Channel Editing Submenus
62	6.2. Velocity Map Submenu
65	6.3. Intonation Table Editor Submenu
66	6.4. Pressure Map Editor Submenu
67	6.5. Default Control Sources Editor Submenu
69	6.6. Program List Editing Submenu
71	6.7. Bin Map Editor
72	6.8. Performance Setup Editor
79	VII. The Program Menu
81	VIII. The Layer Menu

<i>Page</i>	<i>Section</i>
90	IX. Modular Effects Editing
90	9.1. Introduction
90	9.1.1. Conceptual Model
90	9.1.2. Defining & Deleting Modules
92	9.1.3. Patching Modules
92	9.2. Low Frequency Oscillators
92	9.2.1. Local Low Frequency Oscillator 1
93	9.2.2. Local LFO2
93	9.2.3. Global LFOs
94	9.3. Attack Sustain Release Envelope Generators
94	9.3.1. Local ASR1
95	9.3.2. Local ASR2
95	9.3.3. Global ASRs
96	9.4. Mixers
97	9.5. Inverters/Negators
98	9.6. Amplitude Envelopes
98	9.6.1. Local Amplitude Envelope
103	9.6.2. Envelope 2
104	9.6.3. Envelope Control
105	9.7. Pitch Control
107	9.8. Amplitude Control
108	X. Programming Tutorial
108	10.1. Introduction
108	10.1.1. Initial Setup
109	10.2. Vibrato
110	10.3. Tremolo
111	10.4. Chorus
112	10.5. Leslie
114	10.6. Using Velocity Triggers to Change Sounds
115	10.7. Performance Setups and MIDI
116	10.8. Conclusion
118	XI. Reference
118	11.1. Buttons in the Naming Sequence
118	11.2. Performance Functions of Buttons, PLAY Mode
119	11.3. Compiled Effects Parameters
120	11.4. Control Source List
122	11.5. Standardized MIDI Control Numbers
123	11.6. The Master Menu
124	11.7. The Program Menu
125	11.8. The Layer Menu
126	11.9. Modular Effects Menus

<i>Page</i>	<i>Section</i>
130	XII. Appendix
130	12.1. Value Resolutions
130	12.1.1. Time Values
130	12.1.2. Rate Values
131	12.2. Self-Diagnostics
132	12.3. 1000 Series SysEx Messages
136	12.4. Demo Objects Format
138	12.5. K1200 Programs
142	K1200 Soundfiles
144	12.6. Audio Outputs
144	12.6.1. Choosing Cables
144	12.6.2. Audio Connector Wiring
144	12.6.3. Use of Direct Boxes
146	12.7. Specifications
148	XIII. Index

Part I

Performance Guide

Section I

INTRODUCTION

1.1 About This Manual

This manual has been designed to provide you with all the basic information you'll need to set up and operate your new K1200.

Section I provides introductory information that is of interest to every K1200 owner. Section 1.3 (*Summary of Precautions*) is particularly important. We urge you to read it before you connect and operate your new instrument.

Section II shows how to connect your K1200 Keyboard.

Section III tells how to operate your new instrument. Procedures from basic program selection to creating multi-timbral polyphony with MIDI sequencers are explained in a step-by-step fashion.

Section IV presents instructions for basic program editing. Here, you will learn how to create layers, keyboard splits, and to modify existing Programs; how to add pre-programmed "compiled effects" to your presets; and how to save presets to the K1200's internal memory (RAM).

The Kurzweil K1200 features the exceptional sonic quality of Kurzweil samples, coupled with the richness of digital synthesis and the flexibility of modular synthesizers. We urge you to study this manual carefully, and keep it with your instrument for reference, in order to make best use of your K1200's extraordinary musical potential. Once you've become familiar with the information in this part of the manual, you'll be ready to move on to Part II, the *Programming Reference*, and begin exploring the immense creative potential of your K1200.

Thank you for purchasing your new Kurzweil K1200!

1.2 Unpacking & Inspection

The Kurzweil K1200 is delivered in a single corrugated cardboard shipping container. Upon unpacking your K1200, immediately inspect it for shipping damage. If it has been damaged in transit, you must place a claim with the carrier or with your Kurzweil dealer. Kurzweil Music Systems assumes no responsibility for shipping damage.

The carton should contain:

- Your new K1200
- Two foot pedal switches
- A three-prong AC power cable
- This *Musician's Guide*
- A metal music rack
- A Warranty Registration Card

If any of these items is missing, contact your Kurzweil dealer.

When you first unpack your K1200, you'll notice that there is a strip of clear plastic tape covering the front-panel label plate. Its function is to protect the plate from scratches when the unit is being packed. You'll find that it peels off very easily.

We recommend that you save the shipping carton and protective inserts. For carrying and shipping, they provide the best protection short of a custom-made road case.

1.3 Summary of Precautions

- Keep this *Musician's Guide* and refer to it whenever you connect and operate your K1200 Keyboard.
- Make sure that your AC power connection conforms to the guidelines given in Section 2.1 of this manual.
- To protect against shock hazards and ensure proper operation, *never* cut or disconnect the power cable ground pin. Don't use the power cable if it appears frayed.
- If the fuse in your K1200 should blow, you must replace it with another of the same physical size and current rating. *Never* use a fuse with a higher rating, and *never* attempt to bypass the fuse with a hardwired connection.
- The Kurzweil K1200 is normally shipped ready to operate with a mains AC voltage of 100 to 120 volts. If your local AC service is 200 to 240 volts, you *must* set the unit for the higher voltage. Follow the procedure given in Section 2.1 of this manual. *Attempting to operate the K1200 at 200 - 240 volts AC without properly setting the voltage selector switch will cause extensive damage to the unit.*
- Do not open the K1200 case. There are no user-serviceable parts inside. Refer servicing to an authorized Kurzweil Service Center.
- Do not spill liquids into or on the K1200 chassis.
- Do not allow the K1200 to overheat. The K1200 will operate at temperatures from 0–55° C (32–131° F). Make certain that your setup allows adequate ventilation to maintain this temperature range.
- Do not connect the audio outputs or MIDI connections to a voltage source such as a battery, power supply, mains AC source or amplifier output.
- Use only standard MIDI cables for MIDI connections. Do not use ordinary recording studio DIN cables. If you are uncertain how a cable is wired, don't use it.
- If you try a Hard Reset, be sure to press only the A and B buttons, and no others, when you turn the K1200 back on. Pressing any other buttons while powering up may cause the unit to lock up. Refer to Section 3.9.

1.4 Description of Features

1.4.1 The Kurzweil K1200

The Kurzweil K1200 is a powerful, cost-effective electronic musical instrument for live performance and recording. Combining both sample playback and digital emulation of a traditional modular synthesizer in a single unit, the K1200 offers prodigious programming flexibility and sonic variety. It's multi-timbral, and is capable of responding to information on all 16 MIDI channels in any combination.

The K1200 is a 24-note polyphonic keyboard instrument combining 162 voice presets with a weighted 88-note keyboard, monophonic aftertouch, dual pedal switches and three 10-location programmable memory banks.

The Kurzweil K1200 inherits the sonic legacy of the legendary Kurzweil 250®, the sampling synthesizer whose extraordinary fidelity and realism have made it a mainstay of professional music. Through VLSI (Very Large Scale Integration) integrated-circuit technology, Kurzweil engineers have succeeded in packing the K1200 with 162 preset Programs based on 16-bit floating-point digitally-sampled sounds. As a result, identical voices played on the Model 250 and on a K1200 are virtually indistinguishable from one another.

Section I

The K1200 also incorporates extensive programming features, including both Compiled Effects (pre-programmed, adjustable effects such as Chorus, Vibrato, Tremolo and Leslie) and Modular Effects (the digital equivalent of a traditional modular synthesizer, with complete user control over patch configuration and settings). User-created Programs may be stored in RAM (Random Access Memory) locations; the RAM is battery-backed so that user programs are retained when the instrument is turned off or unplugged.* (Information on programming the K1200 is found in Part II, the Programming Reference.

The K1200 features a comprehensive and flexible MIDI implementation, with full user control over channel assignments, controller assignments, program change mapping and other parameters. Any of the instrument's voices may be assigned to any of the 16 MIDI channels for multi-timbral playback of sequences, and intelligent allocation of notes minimizes "note stealing." Finally, a unique, built-in MIDISCOPE function allows the instrument to provide a dynamic display of MIDI events as they are generated, and self-diagnostic routines help to pinpoint malfunctions, should they occur.

MONO PRESSURE

CAPABILITY—The K1200 has a sensing strip under the keys which enables it to send mono (channel) pressure signals both over MIDI and to the K1200's internal sounds.

CHANNEL ASSIGNMENT

MEMORY—The assignments you make in PLAY mode—enabling and disabling MIDI channels, and assigning Programs to them—are stored in a memory location called the MASTER Parameter Table. This table is part of the K1200's battery-backed RAM (Random Access Memory), and is retained when the unit is turned off. Thus, all channel assignments will be remembered the next time you power up.

SYSEX FOR CHANNEL EN-

ABLE AND MIDI MODE—You can use system exclusive messages from your computer or sequencer to enable or disable MIDI channels on the K1200. You may also change the MIDI mode—Omni On (Omni), Omni Off (Poly), or Multi (Mult)—via SysEx messages. Section 12.3 in the Programming Reference tells you how.

1.4.2 K1200 Structure

The Kurzweil K1200 is a multi-timbral instrument which allows flexible creation of split and layered timbres in many combinations. An individual timbre, or a fully-defined split and/or layered timbre setup, is termed a **Program**.

The K1200 features 162 preset Programs which reside in ROM (Read Only Memory). Each Program has a unique name (for example, Grand Piano or Jazz Organ) and one or more Program numbers (not the same as the PROG ID#, which we'll explain in Section VI (Parameter 009, PList). Factory Programs are numbered from 1 to 163, and 201 to 363. These two groups of Program numbers are actually the same Programs arranged in different combinations. This is a feature of the Program Lists stored in the K1200's RAM (see Section VI, Parameter 009).

Factory Programs cannot be erased; ROM is a permanent storage medium. You may, however, modify the Programs (by making a copy of the Program and changing the copy),

* You may also use ObjectMover™ software to dump Programs and other items to your personal computer. ObjectMover is available from your Kurzweil dealer.

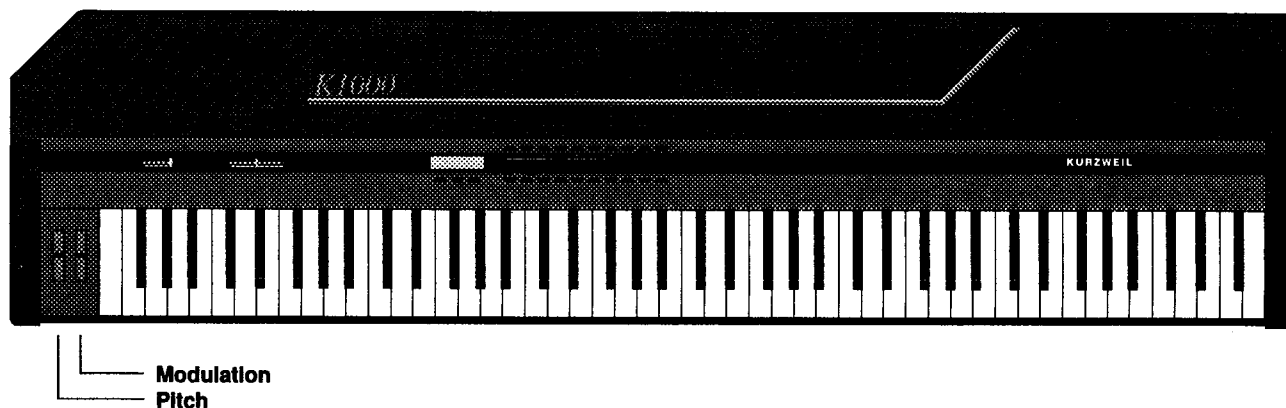

Figure 1-1 K1200 Front Panel

then rename them and store them in RAM. Program numbers 401 - 499 are reserved for User-defined Programs, but as you'll learn, they can be assigned to any Program number, using the Program Lists.

A Program may have up to four individual **Layers**. Each Layer may have its own **Soundfile**, or timbre, assigned to it, and each also may have a distinct set of **Effects** applied to that timbre. Individual Layers can be assigned to respond to any range of keys on the K1200 keyboard (or that of a separate MIDI controller), and the key ranges for successive Layers of a Program may or may not overlap. Programs having Layers whose key ranges do not overlap are referred to as **Split Programs**.

Programs can be assigned to Performance Setups, which allow you to split the K1200's keyboard into three Regions. Each Region can have its own MIDI channel and Program assignments, as well as its own

set of assignments for controls like Pitch and Mod Wheel, transposition, and foot pedals (there are limits to the use of continuous controls; see Section VI, "Region Modes").

1.4.3 Front Panel Controls & Display

As the K1200 front panel graphics indicate, several of the control buttons serve different functions depending upon the instrument's operating mode. The K1200 has two basic operating modes: PLAY and EDIT. For each button whose action changes with the operating mode, the upper label indicates its PLAY mode function and the lower, its EDIT mode function.

PLAY / EDIT — Toggles between the two operating modes of the K1200.

MODE / LAYER — In PLAY mode, this button selects MIDI receive modes (Omni, Poly, or

Mult). In EDIT mode, the LAYER button serves two functions. If you're editing Programs, you'll use this button to scroll through the Layers of the currently selected Program. When editing Performance Setups, the LAYER button scrolls through the Regions of the current Performance Setup.

CHANNEL / MENU — In PLAY mode, these buttons cycle through the 16 MIDI channels, wrapping at either end (for example, pressing the Down button when channel 1 is selected takes you to channel 16). In EDIT mode, they are used to access the various Edit Menus.

PROGRAM / PARAMETER — These buttons cycle through the Program numbers in PLAY mode, wrapping at either end. In EDIT mode, they select specific programming Parameters.

VALUE — In PLAY mode these buttons function only when the K1200 is set for Mult mode play; in this case, they act to

Section I

enable or disable the currently displayed MIDI channel (see Section 3.7). In EDIT mode, they are used to alter the value settings of Parameters (YES/UP increases the value, and NO/DOWN decreases it) or to respond to question prompts from the K1200 (for example, "Delete Program?").

Note — If you press and hold a button, its action will begin repeating rapidly after a brief interval. You can use this feature to move quickly through the range of a button's function.

DISPLAY — This back-lit, two-line, 32-character LCD (Liquid Crystal Display) indicates the current status of the instrument. In EDIT mode, it displays Menu choices, Parameter values and prompts. The Display also functions as a power indicator.

VOLUME — This slider controls the K1200's audio outputs.

DATA ENTRY — This slider provides a quick method for entering Values in Edit mode.

Pitch Wheel — This spring-loaded, center-detent controller is used primarily to bend notes. Its range and action are programmable (see the *Programming Reference*).

Modulation Wheel — The Mod wheel is also center-detented, but is not spring-loaded. It usually controls depth of modula-

tion, but may be programmed to control other functions.

The K1200 calibrates its controls when you turn it on, and the position of the Mod wheel at that time becomes its zero point. Be sure that the Mod wheel is at center before you turn on the K1200. If you hear Mod Wheel effects even when the Mod Wheel is centered, turn off your K1200, center the Mod Wheel again, and turn on the K1200 again.

A, B, C: Alphabetic buttons— These buttons select the K1200's Bin Banks (see Section 3.3.2).

0 - 9 Numeric Buttons — when you use one of the alphabetic buttons to select a Bank, the numeric buttons select a specific Bin in the selected Bank. The Bins usually contain Programs or Performance Setups, but they can hold any of seven different Object types. Please see Section 3.3.2 for a full description of Bin Banks and Bin Maps.

When in PLAY Mode, you'll use the numeric buttons with the ENTER button to select specific Program numbers. This is described in Section 3.3.1.

In EDIT mode, the buttons act as shortcuts for data entry. [0] represents the minimum allowable Value for the currently selected Parameter, and [9]

represents the maximum. The buttons in between divide the range of Values for the current Parameter in equal increments. Pressing two adjacent numeral buttons simultaneously gives you a Value between the Values corresponding to those two buttons when pressed individually. In all, the data entry buttons give you 19 Values between minimum and maximum for the currently selected Parameter.

ENTER/COMPARE—The ENTER/COMPARE button on the K1200 has a dual function. When in PLAY mode, it is used to select Programs by number, as described in Section 3.3.1. In EDIT mode, it activates the Compare function, which is described in Section 4.1.4.

STORE—In PLAY Mode, pressing the STORE button starts the process which lets you save Programs to the Bin Banks. In EDIT mode, pressing the STORE button will invoke the question "Save Program?" (or whatever Object you happen to be editing).

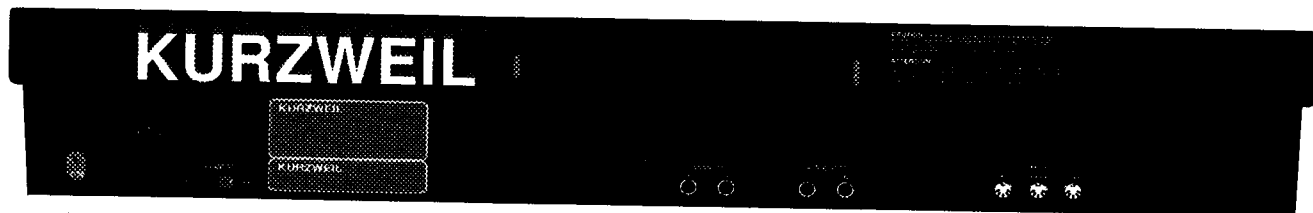

Figure 1-2 K1000 SE II Rear Panel

1.4.4 Rear Panel Controls & Connectors

AUDIO OUT — The K1200 features two outputs labeled LEFT and RIGHT, respectively. The connectors are standard 1/4 - inch monophonic phone jacks.

PEDAL — The K1200's pedals connect to these 1/4 - inch phone jacks. Normally, Pedal 1 controls Sustain and Pedal 2 Sostenuto. The pedals' functions are programmable.

The K1200 calibrates its pedals when you turn it on. If you hold a pedal down when turning on the K1200, its function will reverse. Be sure that the pedals are in the proper position when you turn on your K1200.

MIDI IN — This port receives data from a MIDI control source (such as another keyboard or a computer sequencer).

MIDI THRU — When MIDI data is received at the MIDI In port, the K1200 echos that data here.

The Thru port is used to chain MIDI devices together.

MIDI OUT — This is the K1200's output port for transmitting MIDI data to other devices (see Section 3.5).

AC Power Inlet — This three-pin NEMA connector mates with the power cable supplied with the K1200. To ensure safety and proper operation, *do not use an ungrounded power cord with your K1200.*

POWER — This switch controls AC power to the K1200.

Fuse Compartment — Your K1200 is protected by a 1 Amp, 125 volt fuse. To open the fuse compartment, remove the power cord and gently pry the compartment cover outward with a flat-blade screwdriver.

WARNING:

Never substitute a fuse with a higher rating, and never attempt to bypass the fuse.

Section II

CONNECTIONS

2.1 AC Power

Please read this section carefully before you set up your K1200. When making connections, be sure to follow the precautions given here and in Section 1.3.

The recommended sequence of steps for connecting your K1200 is:

- 1) Make certain that your K1200 is set for the correct AC line voltage. If not, follow the instructions in Section 2.1.
- 2) Plug the power cord into the AC Inlet of the K1200, then plug it into a grounded AC outlet.
- 3) Connect the K1200's audio outputs to your sound system.
- 4) Connect a standard MIDI cable from the K1200's MIDI Out port to the MIDI In port of the next instrument in your setup (optional).
- 5) Turn on the K1200 (it takes about 3 seconds to power up), then turn on your sound system.

The specific information that you need to perform these steps is given in this chapter. Refer to Figure 2-2 when you make your connections, and be sure to keep track of the Left and Right audio channels.

Before connecting your K1200, check to be sure that it is set for the correct line voltage. The line voltage selector is located on the rear panel, at the end nearest the AC power inlet (see Figure 2-2). Its setting is visible through a small opening in the panel.

To change the setting, insert a flat-blade screwdriver through the opening into the switch slot. Turn it gently clockwise until the switch clicks into place, then remove the screwdriver and inspect the switch to be sure that its setting corresponds to the local line voltage.

Caution: Operating the K1200 at 220 volts without setting the voltage selector switch properly will seriously damage the unit.

Your K1200 is supplied with a three-prong power cable, and will operate best if it is connected to a grounded AC outlet. This type of outlet is standard in the United States and is now quite common, although older buildings may have simple two-prong ungrounded outlets.

If your outlet is not fitted for a ground pin, you will have to use an adapter, as shown in Figure 2-1. You can purchase adapters like this at any hardware store. Notice that the adapter's ground wire (or lug) must be attached to the outlet plate mounting screw. *Don't cut or break off the ground pin on your K1200's power cable.*

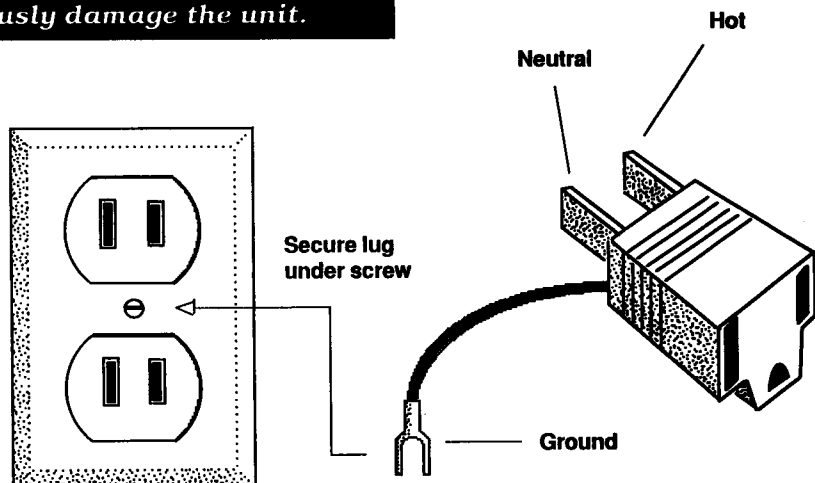

**Figure 2-1 Grounding AC Adapter
(Use ONLY on Ungrounded Outlets)**

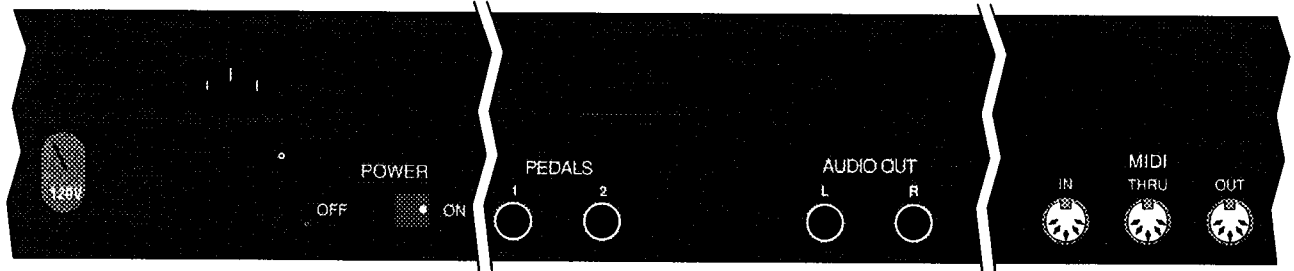

Voltage
Selector
Switch



To 110 Volt AC
grounded outlet

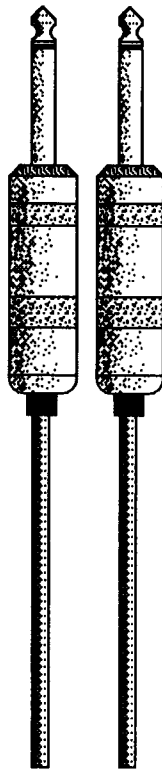

Sustain Sostenuto
Foot pedals
(supplied)

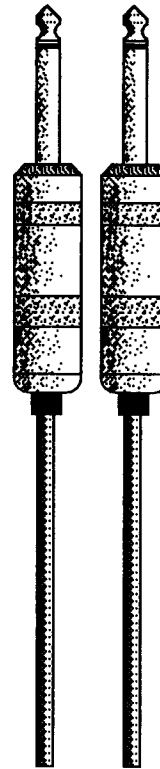

L R
To sound
system inputs



MIDI
cable

To 1200 Expander
or other MIDI-
controlled unit
(optional - see
Section 3.5)

Figure 2-2 Connecting The Kurzweil K1200

Section II

2.2 Audio Outputs

The K1200 Keyboard is actually a specialized computer and, like other types of computers, it is susceptible to AC power surges (these may cause it to “freeze up” unexpectedly or, in the worst case, could damage the internal circuitry). For this reason, you should make sure that the unit is connected to a source of clean AC power of the proper voltage and line frequency.

Note —You can protect your K1200 from power surges by purchasing and using a “surge suppressor” outlet. (Again, check with your local hardware store or a computer dealer.)

To connect the K1200 to your audio system, you’ll need to know two things:

Input sensitivity — Identify the *least sensitive* input (that is, the input which “expects” the highest signal level).

Input connectors — Determine what type of connector that input requires.

The K1200 delivers a line-level (-10 dBV, or 0.3 Volts) stereo signal, and its output connectors are standard 1/4 - inch monophonic phone jacks. Most sound systems are designed to handle this type of output directly. If yours is not, then you may need to use special cables or adapters.

This section offers guidelines for connecting to various types of systems. Look for more information in the manual for your sound system.

2.2.1 Instrument Amplifiers

Instrument amplifiers are generally monophonic, and they usually feature inputs that are designed to connect directly to a guitar or other low-level source. The input connector is invariably a monophonic 1/4 - inch phone jack.

You can connect the K1200 directly to an instrument amplifier using a standard audio cable (guitar cord), as shown in Figure 2-3(a). If your amplifier has dual inputs, you may connect each output to one of the inputs.

If your amplifier has only one input, use an audio cable to connect one K1200 output to it (it doesn’t matter which), then turn to Section 4.5 of this manual and use Master Parameter 020 to set your instrument for mono output. **Don’t try to use a “Y” adapter to connect both outputs to a single input.**

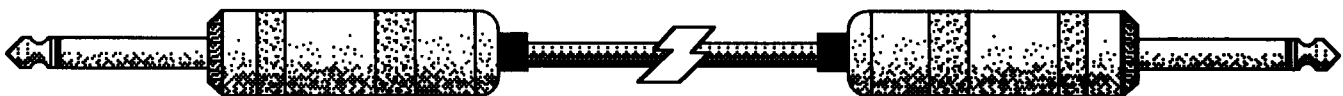

Figure 2-3(a) Standard Audio Cable (Phone to Phone)

Be aware that, since the K1200 puts out a stronger signal than a guitar does, you may have to lower the VOLUME setting to avoid distortion.

2.2.2 Stereo Systems

Home stereos normally have several inputs designed to handle a variety of sound sources. The K1200 is compatible with so-called "line level" home stereo inputs; these will be labeled LINE, AUX, TAPE, TUNER or CD IN. **Don't use the PHONO inputs.**

The connector required will usually be an RCA-type male (sometimes called a "pin jack"). While you can buy adapters that will fit on the end of a standard audio cable and mate with an RCA input, we don't recommend that you use them. You'll get much better results if you use 1/4 - inch phone to RCA cables, as shown in Figure 2-3(b).

2.2.3 Mixing Consoles

Mixing consoles come in many shapes and sizes, with correspondingly varied capabilities and requirements. With consoles, it's particularly important to read and follow the recommendations given in the equipment's instruction manual.

Small semi-professional and DJ-type mixers usually incorporate LINE inputs with either 1/4 - inch phone or RCA-type connectors (on DJ mixers, the line-level inputs may be labeled TAPE). The K1200 is entirely compatible with such inputs; use whichever of the cables in Figure 2-3 is appropriate.

Some larger home recording consoles offer a choice of using either LINE or MIC inputs for line-level sources. (You can identify such consoles by looking for a MIC pad switch and/or trim control on the

input strip.) The LINE input connectors may be either 1/4 - inch phone or RCA; with consoles of this class, the MIC connectors are normally three-pin XLR-type.

In this case, you can easily connect the K1200 to the LINE inputs — but sometimes there are distinct advantages to using MIC inputs. To do so, you'll need either a pair of adapters or cables with 1/4 - inch phone connectors on one end and XLR-type on the other (or you might use either a direct box or impedance-matching transformers; see the Appendix). If your Kurzweil dealer doesn't stock the cables you need, try a home electronics store. You may not be able to find adapters or cables like this off-the-shelf, however, so you might have to get out the soldering iron. Refer to the Appendix of this manual for information on making your own cables.

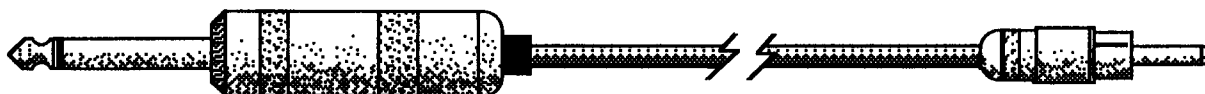

Figure 2-3(b) Adapter Cable (Phone to RCA)

Section III

OPERATION

3.1 Getting Started

Before you power up your K1200, set its VOLUME slider to minimum (fully to the left). Turn on the K1200 and wait for the display to initialize (about three seconds), then turn on your sound system.

When you first turn on the K1200, the front-panel display should look similar to Figure 3-1. This is a typical PLAY mode display, showing the current MIDI mode and channel, the currently-selected Bin Bank (see Section 3.3.2), the Program number and the Program name.

If your display reads "No PRG Assigned," press either of the PROGRAM buttons to select a Program other than number 000.

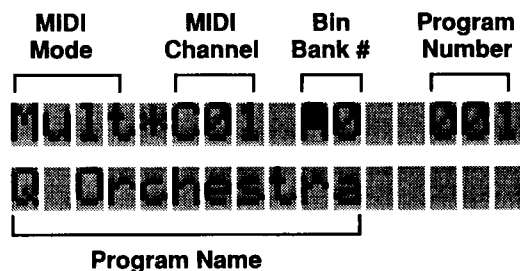

Figure 3-1 PLAY Mode Display

3.1.1 Setting the Output Level

The VOLUME slider allows you to match the level of the K1200's audio outputs to the input sensitivity of your sound system. In general, you should use the highest setting that does not overload the sound system input; this will result in the best audio quality with the least noise.

Instrument amplifiers — Most instrument amplifiers are designed to work with very low-level sources, and the K1200 can easily overload them. To avoid distortion, you'll have to use a fairly low VOLUME setting.

Starting with the K1200's VOLUME slider at minimum, set the amplifier's volume control to about 20% to 30% of full volume. Then, while playing the keyboard, slowly bring up

the K1200 volume until the sound just begins to distort. (If it gets too loud, back off on the amp's volume control.) Now, reduce the K1200 volume just until the sound is clear again, and use the amp's volume control to adjust for a comfortable listening level.

Home stereos — With home stereos, you normally should be able to leave the K1200's volume at maximum and set the stereo's volume control to taste. If you get distortion, try backing off on the VOLUME slider until it disappears. *Use caution; the K1200 can generate more very-high and very-low frequency energy than the typical record, tape or CD. These signals can damage your loudspeakers unless you keep the volume at a modest level.*

Mixing consoles — If you are using a LINE input, set the VOLUME slider to maximum and back it off only if distortion appears at normal fader settings.

With MIC inputs, use the pad (if there is one). Set the K1200 VOLUME to maximum, and use the console input trim control to adjust for nominal OVU readings when the console faders are set to the unity gain position (usually marked '0' or highlighted on the panel markings). If you can't get enough level, try switching the pad out.

3.2 Automatic Demo Feature

If you don't get sound:

- Make sure that everything is turned on (don't laugh — even the most experienced pros get caught by this one!).
- Use MIDISCOPE to make sure the keyboard is sending information to the sound engine (see Section 3.8).
- Check your audio connections against Figure 2-2.
- If you're using a mixing console, be sure that the correct channels are enabled and assigned, the masters (and submasters, if applicable) are up, and the monitor is correctly assigned and turned up.
- Be sure that you haven't selected Program 000; it's not a sound.
- Turn the K1200 off, then on.
- Try replacing your audio and/or MIDI cables.
- Perform a Soft Reset (see Section 3.9).
- Perform a Hard Reset (see Section 3.9).
- Call your Kurzweil dealer.

Included with your new K1200 is a RAM-based set of demonstration sequences. These sequences highlight the K1200's sounds and multi-timbral capabilities. You can start these Auto-demo sequences directly from PLAY Mode.

Start the Demo (enter DEMO Mode) by pressing the following three buttons simultaneously: the PLAY/EDIT button and both the PROGRAM buttons. In a few seconds, the first Demo sequence will begin to play. The Demo will automatically play through all the sequences in the Demo set, in the order of their Object ID numbers. When the highest-numbered sequence has been played, the demo will repeat.

While the sequences are playing, the K1200's display will show the word "Demo" in the upper left corner. As each sequence begins, the display will show the name and number of the sequence for a few seconds, then will return to the DEMO Mode display. (The only difference between the DEMO Mode display and the PLAY Mode display is that the word "Demo" appears where the MIDI mode information normally is seen.)

While the Demo is running, you can use the ENTER and numeric buttons to select different Programs, or you can scroll

through the Program Lists with the PROGRAM buttons.

The Demo may be stopped at any time by pressing the PLAY/EDIT button and PROGRAM buttons together. This returns you to PLAY Mode. The next time you enter DEMO mode, the Demo will begin with the next sequence in the list—unless you have done a Soft reset or powered down since the last time you played the Demo. If so, the Demo will begin with the first sequence in the list.

If you want to free up some memory space, you can delete the Demo sequences by doing a hard reset (Section 3.9). This will erase them **permanently**. If you're going to do this, you should do it before you save any of your own programming work, since a hard reset deletes all RAM information.

You also can use Parameter 035 to delete individual songs.

You can use ObjectMover™ to manipulate Demo sequences. ObjectMover is a patch librarian application available through your Kurzweil dealer. Macintosh and Atari versions are available; an IBM-compatible version is currently under development.

When you open the K1200 using ObjectMover, the Demo sequences will appear individually in the K1200 window with all the other RAM Objects. Their

Section III

Object type is indicated by the characters "DEMO" followed by an Object ID number and the name of the sequence.

ObjectMover can be used to change a Demo sequence number or name, and to load, save or delete a Demo sequence—in other words, ObjectMover treats DEMO Objects like any other 1000 Object.

Macintosh ObjectMover diskettes contain an application called Demo File Converter 1.0, which will enable you to convert any type 0 (zero) standard MIDI file to the K1200's format. If you have a sequencing program or hardware sequencer which can save sequences as type 0 MIDI files, you can convert them into DEMO Objects. If the converted sequence files are 64K bytes or smaller in size, they can be loaded into the K1200's RAM and played back in DEMO Mode. A 64K DEMO Object is roughly equivalent to 8,000 notes. If your computer is not a Macintosh, and you're interested in writing your own file conversion program, you can get the Demo Object data format documentation from Kurzweil User Support.

If you already own Macintosh ObjectMover, or if you purchase a Macintosh ObjectMover package which does not include Demo File Converter 1.0, you can get the conversion program

(Mac version only) from your Kurzweil dealer.

If you're interested in developing your own demonstration sequences to load into the K1200's RAM, turn to Appendix Section 12.4 for a description of the DEMO Objects' file formats.

3.3 Exploring Programs

Now that you've got everything working, you're ready to explore the world of great sounds that your K1200 offers!

Use the PROGRAM buttons to change Programs: the UP button increases the Program number, and the DOWN button decreases it. To move rapidly through several Programs, press and hold one of the buttons. After a brief delay, the K1200 will scroll through the Program list.

If you press both PROGRAM buttons at the same time, the K1200 will jump to the beginning of the next Program List (Programs 101, 201, 301, etc.). This dual press technique is used for many of the K1200's functions, allowing you to bypass long lists or get to frequently-used elements.

To provide the greatest ease of operation in a variety of practical situations, the K1200 actually offers three different ways to select Programs. The simplest and most direct is the one described above — using the PROGRAM buttons to scroll through the Program list.

In performance situations, you'll want to change Programs more quickly. The K1200 allows you to do this in two ways: you can use the ENTER button and numeric keys to select Programs by number, or you can select them from any of the K1200's three Bin Banks (please see Section 3.3.2).

3.3.1 Selecting Programs By Number

If you know the number of the Program you wish to select, you can select it directly:

Press ENTER. The lower line of the display will show:

Program #:

Using the numeric buttons, enter the number of the Program that you want. (You don't have to enter leading zeros; for example, to get to Program 023, just press '2' and '3.') The display will show the numbers as you enter them.

Press ENTER again, and the K1200 will revert to the standard PLAY mode display, with

the Program that you selected ready to play.

You can enter a Program number from 0 to 999 using this method. If, however, you select a Program number which doesn't have a Program stored there, the display will show "not found" briefly, then will return to the previously selected Program.

3.3.2 Using the Bin Banks

SELECTING PROGRAMS: For even faster Program access, the K1200 has a set of three Bin Banks. These Banks, labeled A, B and C, each contain ten "Bins," where you can store any ten Programs that you choose.

To select a Program from a Bin Bank, first press A, B, or C to select a Bank. The display's upper line will show which Bank has been selected. The letter indicating the selected Bank will be followed by a hyphen, prompting you to press a numeric button. When you do, the Program stored in that Bin is instantly selected, and you're ready to play.

Once a Bank is selected, you can select any of the Programs in that Bank simply by pressing one of the numeric buttons. The Bank will change only when you press one of the Bank (alphabetic) buttons.

When you select a Program from the Bin Banks, the K1200 automatically creates a temporary Performance Setup (see Section 6.5) that defines the performance characteristics of that Program. This temporary Performance Setup can be changed in PLAY Mode, using the front panel buttons in special "shortcut" combinations. See Section 3.4. Performance Setups can be modified in EDIT Mode, also, using the Performance Setup Editor in the Master Menu (section 6.8). You also can edit the default characteristics of the temporary Performance Setup using the Default Control Sources Editor in the Master Menu (section 6.5). This will affect the performance of every Program you select from the Bin Banks.

STORING PROGRAMS: To assign a Program to a Bin Bank, press STORE, and the display will show something like this:

A0 = PSetup 3
(current)

This means that Bank A, Bin 0 is currently selected, and that PSetup 3 is ready to be stored in that Bin Bank location.

Press the CHANNEL DOWN button once to change "PSetup" to "Program." The K1200 can store several different types of Objects. The first step is to

select the type of Object to store—in this case a Program.

Now press A, B or C to select the Bank you wish to use. The display will show your selection. Now press one of the numeric buttons to select the desired Bin.

Now that you've selected the Bank and Bin, select the Program you wish to store there by using the PROGRAM buttons to scroll through the Program list (dual presses skip to 101, 201, etc.) You can change the Bank, Bin and Program as many times as you like.

When you have selected the Bank, Bin and Program you want, press STORE again. The lower line of the display will show "Stored!" for about a second, then will return to where it was before you began the Store operation.

Most of the K1200's Bin Banks are preprogrammed to contain Programs with a variety of timbres. If, however, pressing the Bin buttons uncovers items like VelMaps, PrsMaps, or ITbls, see the discussion of Parameter 011 in Section VI.

OTHER USES FOR BIN

BANKS: As you have discovered already, the Bin Banks can store not only Programs, and Performance Setups, but several other features as well.

Section III

These include Bin Maps (Section 6.7), Velocity Maps (Section 6.2), Pressure Maps (Section 6.4), Intonation Tables (Section 6.3), and Songs (DEMO Objects—see Section 3.2). Any of these items—which we call “Objects”—can be stored in any Bank and Bin. Once you’ve become familiar with the features of each of these Objects, you’ll store them in various combinations in the Bin Banks to give yourself enormous control over your K1200’s performance configuration.

To store any of the Objects we’ve just mentioned into a Bin Bank, start the same way as you did to store a Program: press the STORE button. The display will look something like this:

A0 = PSetup 3
(current)

Now press either of the CHANNEL buttons to scroll through the list of Object types which can be stored; there are seven of them. The list will wrap around when you get to the end.

When you see the **type** of Object you wish to store, use the PROGRAM buttons to scroll through the available Objects of that type. If the display does not change, there aren’t any other Objects of that type available.

When you find the specific Object you want to store, make sure the Bank and Bin assignments are correct, then press STORE. The lower line of the display will show “Stored!” briefly.

The Bin Banks give you 30 memory locations, where you can store any of seven different types of Objects. The K1200 thinks of those 30 locations as a single Object called a Bin Map. The K1200 is capable of storing dozens of these Bin Maps, which you can create, modify and select using the Bin Map Editor. This will be explained more fully in Section 6.7.

3.4 PLAY Mode Performance Shortcuts

When you turn on your K1200, it’s ready to perform (hence the term “PLAY Mode”). The keyboard triggers notes, the Pitch and Mod wheels have their respective effects, the foot pedals have their effects, and so on. These and many other features make up what we call the K1200’s Performance Setup. Your K1200 has a default Performance Setup, which instructs the various features and controls to function the way they do now.

You can modify the default Performance Setup, then rename it and save it in RAM.

You can create as many Performance Setups as you like in this fashion. By storing the Performance Setups in the Bin Banks, you can select an entirely different configuration for your K1200 (and other MIDI devices) by pressing a single button!

Each Performance Setup (we’ll abbreviate the name as PSetup from now on) features three keyboard regions. Each region can play a different Program, and can transmit on a different MIDI channel. Each region also can have its own assignments for controls like Pitch and Mod wheel, and foot pedals.

A full discussion of how to edit Performance Setups is given in Section 6.8. For now, we’ll give a brief description of the special features you can use in PLAY Mode.

SELECT MIDI CHANNEL The default PSetup’s center Region covers the entire K1200 keyboard, and transmits on MIDI channel 1. (The other two Regions also transmit on channel 1.) Use either of the CHANNEL buttons to change the transmission channel for the currently selected Region.

SELECT PROGRAM NUMBER You can change Program numbers by scrolling with the PROGRAM buttons, by pressing

ENTER - Program number - ENTER, or by pressing a numeric button to select from the currently selected Bin Bank.

SELECT CURRENT PSETUP REGION The PLAY Mode display indicates the currently selected PSetup Region: L for Left, C for Center, R for Right. The default PSetup makes the center Region current. If you want to select another Region, to change its Program or its transposition, use the following buttons:

Press A and B together to select the Left Region;
Press B and C together to select the Right Region;
Press A and C together to select the Center Region.

SELECT BIN MAP If you have a large number of Programs (or other Objects) that you use frequently, you probably will find that the 30 Bin Bank locations are not enough. By using the Bin Map Editor (Section 6.7), you can create numerous collections of Bin Bank assignments. Each of these Bin Maps contains 30 memory locations which correspond to buttons A0 - C9. These Bin Maps can be selected in the Master Parameter Menu, or directly from PLAY Mode.

To select a Bin Map from PLAY Mode, press the 0 and 1 buttons together. The lower line of the display will change to show:

Select Bin Map?

Simply press any of the numeric buttons, and the Bin Map with that ID number will be selected. The ID number is not normally visible, but you can see it when in the Bin Map Editor—see Section 6.7.

Note that only two Bin Maps—Bins and QuickMaps—are present in the K1200's memory when it arrives from your Kurzweil dealer. If you select a number which does not have a Bin Map assigned to it, the display will tell you that no map was found, and will return to normal PLAY Mode.

SET SPLIT POINTS Each PSetup has two split points associated with it. The split points define the lowest and highest keys of the Center Region. You can set these split points in the Performance Setup Editor, or you can set them using the numeric buttons and the keyboard.

To set the split points for the currently selected PSetup:

Press 2 and 3 together. The lower line of the display will show:

Strike 1st key!

Strike the key you wish to be one of the split points. The display will show:

Strike 2nd key!

Strike the key you wish to be the other split point. The lower line of the display will briefly show the keys you struck. They become the low and high notes of the Center Region. The Left Region is every note lower than the low note; the Right Region is every note higher than the high note. The display then returns to the normal PLAY Mode information.

You can press NO or PLAY/EDIT any time before striking the second key—this will cancel the operation.

SET TRANSPOSITION You can quickly transpose the currently selected Region—as well as the sounds of connected MIDI devices—to enable you to play in any key you wish. To transpose from PLAY Mode:

Use the A, B, and C buttons, if necessary, to select the Region to be transposed.

Press 4 and 5 together. The lower line of the display will show:

Strike any key!

When you strike a key, the K1200 measures, in semitones, how far away the key you struck is from Middle C (C4, MIDI note number 60). The K1200 then transposes its internal sounds, and its MIDI

Section III

output, by that number of semitones. The display shows how many semitones the K1200 has been transposed.

You can cancel the transposition by pressing NO or PLAY/EDIT before striking a key.

Another way to look at this transposition is to imagine that you are "moving" the pitch of the key you strike so that it is played by Middle C. For example, if you wanted to transpose up a fourth (five semitones), you would strike F4. This would transpose the K1200 up by five semitones, so that playing Middle C would result in a note that was five semitones higher, namely F4.

SEND MIDI PROGRAM CHANGE You can send a single MIDI Program Change command at any time, on any MIDI channel. To do this:

Press 6 and 7 together. The lower line of the display will show something like:

Chan 1 Prog 1

Use the CHANNEL buttons to change the MIDI channel you want to use for the message. Use the PROGRAM buttons to change the Program number you wish to send. Or enter the Program number using the numeric buttons.

Press NO or PLAY/EDIT to cancel. Press YES, ENTER, or STORE to send the change.

MIDI allows Program change numbers of 0 - 127 to be sent. The K1200 will not allow you to select Program numbers higher than 127, since they're undefined in the MIDI spec.

ALL NOTES OFF MIDI messages sometimes get garbled or misinterpreted by the receiving device. One example of this kind of error is the "stuck note." If a Note On message is received, but no corresponding Note Off message is received to turn the note off, the note will sound indefinitely (until the next Note Off for that note number is received). There is a special All Notes Off message that can be sent to eliminate any notes that are sounding after they should be.

To send an All Notes Off message from the K1200 while in PLAY Mode:

Press 8 and 9 together. The lower line of the display will briefly show "All Notes Off!" then will return to normal PLAY Mode status.

3.5 MIDI Operation

MIDI (Musical Instrument Digital Interface) is an international

standard for data communication among musical instruments.

One of MIDI's most basic features is that it allows one instrument to be played remotely from the keyboard of another (termed the "master" keyboard), or from a computer sequencer. MIDI also permits transmission of a wide variety of messages and commands such as program changes, pitch bender and aftertouch information, as well as "system exclusive" messages that can be unique to a particular brand of synthesizer.

MIDI-equipped instruments may be chained together so that a single master controller can play several synthesizers at once. In order to allow independent control of each unit in a multi-instrument system, MIDI provides for allocating data across a total of 16 "channels" in any combination. Just like a television, a MIDI synthesizer can be set to receive information on a single channel (normally termed the instrument's "basic channel") while ignoring all other channels.

In addition to its solo performance features, the K1200 is a powerful MIDI instrument as well, offering a broad range of controls for both transmitting and receiving MIDI information.

3.5.1 Typical MIDI Connections

MIDI music systems range from very simple to extremely complex, depending upon the capabilities of the instruments and the demands of the application. Regardless of complexity, however, every MIDI system may be understood in terms of very simple models.

In live performance applications, many keyboardists use MIDI to control banks of synthesizers and outboard "expander" modules (such as the 1200 Series Expanders), broadening their selection of timbres, and fattening their sounds through layering.

Figure 3-2(a) shows a simple MIDI setup of this type. The K1200 MIDI OUT port is connected to the MIDI IN of a 1200 Series Expander, and the

Expander's MIDI THRU port is connected to the MIDI IN of another 1200 Expander. MIDI control signals from the K1200 flow to the 1200 Expander and are echoed from its THRU port to the second 1200. This setup permits a variety of doubling and soloing combinations through control of MIDI channel assignments and the settings of individual instruments.

When composing or recording, many musicians use a MIDI sequencer to record and play back individual musical "tracks" (much like a multitrack tape recorder), controlling one or more synthesizers over MIDI.

A simple MIDI sequencing setup based on the K1200 is shown in Figure 3-2(b). The K1200 MIDI OUT port is connected to the MIDI IN port of the sequencer, and the sequencer's MIDI OUT port returns to the K1200 MIDI IN. The K1200 MIDI THRU port

is routed to a 1200 Pro Expander. You'll need to activate the Echo feature of your sequencer (also called Patch Thru or Soft Thru) to hear the 1200 Pro.

In this case, MIDI messages from the K1200 flow to the sequencer input and are recorded in computer memory. During playback, the MIDI data stream passes from the sequencer back to the K1200 MIDI IN and is echoed to the 1200 Expander from the K1200 MIDI Thru port. Individual recorded tracks are assigned separate channel numbers, and the instruments are set to respond accordingly. This seemingly simple setup is capable of complex textures (up to 44 stacked notes utilizing up to 32 distinct timbres).

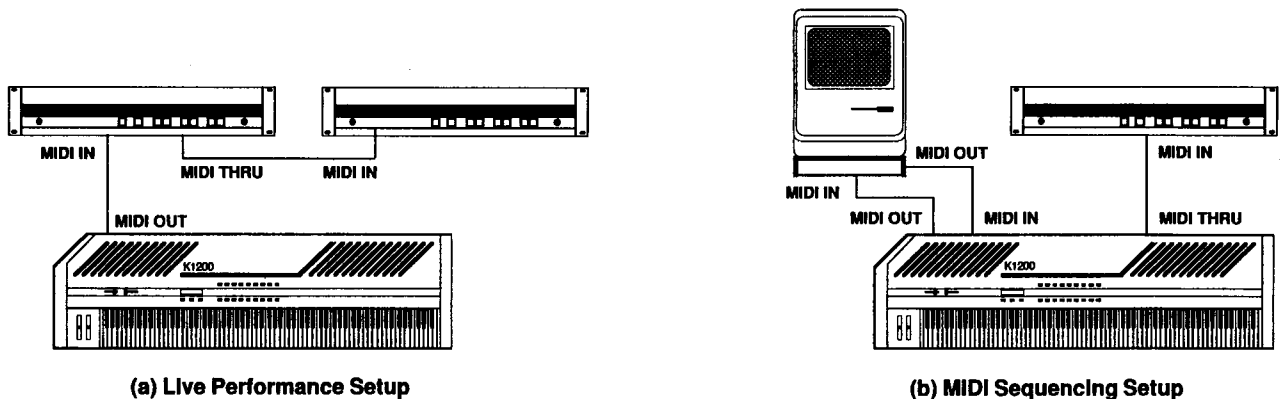

Figure 3-2 Typical MIDI Connections

Section III

3.6 MIDI Modes

The MIDI specification includes a set of "Modes" which determine how an instrument will respond to incoming MIDI data. Normally, MIDI-equipped synthesizers are designed so that they can be switched among three or more different standard MIDI Modes. Each Mode has separate uses in multi-synthesizer and MIDI sequencer environments.

The K1200 features three different MIDI Modes: Omni, Poly and Mult. In all three MIDI modes, the K1200 operates *polyphonically* and *multitimbrally* (that is, it is capable of playing more than one note and more than one sound at a time). The polyphonic limit of the K1200 is 24 notes, and the multitimbral limit is 16 (one sound for each MIDI channel).

MIDI Modes are selected by pressing the MODE switch in PLAY mode.

You can change the K1200's MIDI Mode via MIDI. In OMNI Mode, it will respond to Mode change messages on all channels. In Poly Mode, it will respond only on the basic channel. In MULT Mode, it will respond on all active channels.

3.6.1 Omni

When the K1200 is set to Omni, it will respond to all incoming

MIDI data regardless of channel assignments, and will play everything using the currently displayed Program.

Omni is the simplest of the K1200's MIDI Modes. As a rule, however, Omni Mode is appropriate only when the K1200 is the only instrument receiving data from a MIDI controller (therefore MIDI channel assignments are irrelevant). In multi-instrument systems, setting the K1200 to Omni will cause it to double *all* the instruments from which it receives MIDI data.

3.6.2 Poly

When set to Poly, the K1200 will recognize only MIDI data that it receives on its basic channel (which in Poly mode is the currently selected channel). If you change the current channel with a CHANNEL button, the basic channel changes accordingly.

Poly Mode is useful for multi-instrument systems, when each instrument is set to receive on a single different MIDI channel. It allows independent control of the K1200, with full 24-note polyphony available to the currently-selected Program. When doing multi-track playback from a MIDI sequencer, you might also choose to use your K1200 in Poly mode if it is playing only one part.

3.6.3 Mult

In Mult mode, the K1200 is capable of responding to all 16 MIDI channels in any combination, *with a different Program assigned to each*. In other words, the K1200 can play channel 1 notes using Grand Piano, channel 2 notes using Acoustic Bass, and channel 5 notes using Clarinet — all at the same time!

Clearly, Mult mode is extremely useful for sequenced multitrack playback (Figure 3-2(b)), particularly if you have few synthesizers but want to create complex textures with several instrument sounds. It's also the Mode used by the K1200's PSetups, to allow them to transmit on multiple channels. Mult Mode is automatically selected when a PSetup is selected.

When the K1200 is set to Mult mode, the CHANNEL buttons scroll among the 16 MIDI channels. While only one channel may be displayed at a time, the others remain active and retain their Program assignments.

The PROGRAM buttons are used to select the Program for the channel that is currently displayed. By scrolling sequentially through the channels and assigning a different Program to each, you can very quickly set

up a complex multiple-instrument ensemble.

While the concept of a "basic channel" has little meaning in Mult mode, the K1200 nevertheless remembers its basic channel assignment if you switch to Poly. In the Mult mode display, the basic channel is indicated by an asterisk next to the channel number, as shown in Figure 3-3(a).

3.7 Disabling & Deassigning Channels

There will be times when you will find it desirable to turn off a particular K1200 channel or group of channels. You may, for instance, wish to silence one or more channels when playing back a recorded sequence.

The K1200 offers two methods for doing this: a channel may be *disabled* or it may be *deassigned*. Each method has particular advantages.

Disabling Channels — To disable a channel, press one of the CHANNEL buttons until the channel that you want to disable appears in the display, then press the VALUE NO button. The display should look something like Figure 3-3(b).

A disabled channel will ignore all MIDI data including note events, program changes, and controller events. It retains its current Program assignment, however, and can be re-enabled simply by pressing the VALUE YES button when the channel is displayed.

The channel disable function is very useful when you are slaving several MIDI devices to a single controller. You can easily instruct the K1200 to ignore information on any channel simply by shutting the channel off.

Note that this function works only in Mult mode, and that you

cannot disable the K1200's basic channel.

Deassigning Channels — To deassign a channel, first select the channel using the CHANNEL buttons, then press the two PROGRAM buttons at the same time until the assigned Program is number 000 (or use the ENTER button procedure). The display should look like Figure 3-3(c).

A deassigned channel simply plays a "null" Program. It still responds to MIDI note and controller events, but it won't be heard, since Program 000 is not a sound. To reassign the channel, you must select a different Program for it.

The deassign function is useful when you wish to turn channels on and off automatically over MIDI. (You might, for example, want to do this to control doublings in live performance.)



(a) Basic Channel



(b) Disabled Channel



(c) Deassigned Channel

Figure 3-3 Channel Displays

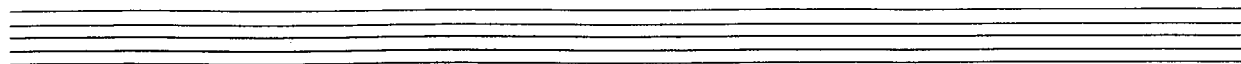

Section III

3.9 Resetting The K1200

To deassign a channel automatically, send it a MIDI program-change message that selects Program 000. You may have to use the Program List feature of the K1200 for this, since you may not be able to select Program 000 directly from your controller. See section 6.6 for an explanation of Program Lists.) To reassign the channel at the appropriate time, send it another program-change message to select the Program that you want it to play.

The deassign function works in all MIDI modes, and does not affect the K1200's transmission of note data.

3.8 MIDISCOPE

The K1200 incorporates a convenient function, called MIDISCOPE, which allows you to see and analyze MIDI events. To run MIDISCOPE from PLAY mode, press the PLAY / EDIT, CHANNEL UP and CHANNEL DOWN buttons simultaneously. The display will read:

MIDI Scope
any button quits

This message will remain until the K1200 receives a MIDI event at its MIDI IN port or from the keyboard. As soon as a MIDI event is received, the display

will look something like Figure 3-4.

The upper line of the display shows the time in milliseconds since the last MIDI event, and the type of MIDI event that has been received. The lower line displays the MIDI channel over which the current event was transmitted, along with specific information about the event (in the case of note events, the key number with attack and release velocity values; for controller events, the MIDI control number and value).

Pressing any front-panel button will cause the K1200 to exit MIDISCOPE and revert to PLAY mode.

Note that you will not hear any sound from your K1200 while in MIDISCOPE. This is normal.

On rare occasions, you may find that you will need to reset your K1200 to get back in action.

A momentary power surge, for example, might "freeze up" the unit, making it unable to respond either to MIDI messages or to any of the front-panel buttons. Likewise, other unforeseen irregularities — such as SCR dimmer noise on the power line or electrical noise on the earth ground connection — may confuse the K1200's digital circuitry, resulting in unexpected behavior. The only solution to such problems may be to reset the unit.

The K1200 allows two types of resets: Soft and Hard.

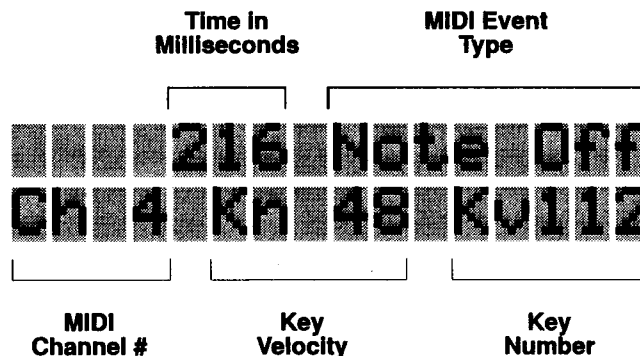

Figure 3-4 Typical MIDISCOPE Display

3.10 Trouble Shooting Reference

3.9.1 Soft Reset

A Soft Reset is the first option to try. It's a convenient way, for example, to reset all MIDI channels to their default states without editing each one individually. To perform a Soft Reset, press the VALUE NO, VALUE YES and PLAY / EDIT buttons together. The K1200 should return to PLAY mode.

A Soft Reset re-initializes the K1200, but it preserves all Program and MIDI mode settings, and also leaves RAM-based user Programs intact.

3.9.2 Hard Reset

The Hard Reset is a last-resort measure, since it not only re-initializes the K1200 but also resets all user-defined settings. In a Hard Reset, all RAM objects are deleted (including Demo songs), and all Parameters of the K1200 are returned to factory settings.

To perform a Hard Reset, first turn the K1200 off. Then, press and hold the A and B buttons simultaneously. While holding them down, turn the K1200 back on. The K1200 will revert to PLAY mode. You also can use Parameter 037 to do a hard reset.

Sustain doesn't seem to be working

This is likely to be due to an All Notes Off message being generated by one or more devices in your MIDI system. For example, some Roland MIDI devices (keyboard, sequencers, MIDI interfaces) will send an All Notes Off message whenever the MIDI data stream stops (for example, if all keys are released on your MIDI keyboard).

The Master Parameter Menu contains a Parameter (023) for adjusting the K1200's response to All Notes Off messages. There are two values: Hard and Soft. If this Parameter is set to Soft, then the K1200 will respond to an All Notes Off message by terminating all notes which are not held on by a MIDI control (like Sustain). Notes held by Sustain or another control will decay normally. At a setting of Hard, all notes will be terminated regardless of any control information. Hard is the default setting.

If you are having trouble getting Sustain to work properly, select this Parameter and set it to Soft. This should take care of the problem.

The Display flickers rapidly and the K1200 hangs up

This can occur in MIDI systems using a computer or sequencer, especially when Program Change information is being generated by either the K1200 or another connected MIDI device. In many cases it will be due to MIDI information bouncing back and forth from your K1200 to a computer or sequencer. If you have a MIDI loop between your K1200 and another MIDI device (the K1200's MIDI Out is connected to the other device's MIDI In, and the other device's MIDI Out is connected to K1200's MIDI In), then MIDI information may be cycling endlessly between the two machines. You'll need to disrupt the loop.

If your K1200 is connected to a MIDI sequencer or a computer running sequencer software that has an echo feature (often called Patch Thru, Play Thru, or Echo), try turning it off. This should correct the problem.

You can always disconnect one of the MIDI cables from the K1200, although this may defeat the purpose of your MIDI system.

Section III

Phasing Effect

Another possible problem related to the MIDI loop described above is a phasing effect in the K1200's sounds. If a patch sounds unusually out of tune or if it sounds as though more than one note is being played at a time (a chorusing effect) you may be accidentally sending many identical Note On commands when you only intend to send one. What is actually happening is that the K1200 is playing a sound twice. This means that one or more of the other devices in your MIDI system is receiving the same Note On information as the K1200, and is passing it through to the K1200. This causes the K1200 to receive two Note On messages for every one that you intended. The delay between messages—even a few milliseconds between the first and second triggering of the sound—can create an unintended phasing effect.

This is easily stopped by disabling Echo (Patch Thru, Play Thru, etc.) on your computer or sequencer. Or you might disable Local Control (Master Parameter 042) on your K1200 rather than disabling Echo in your computer or sequencer. In this case, the K1200 would not play itself, but would send the note information to the computer or sequencer, which would pass it through to the K1200.

Section IV

BASIC EDITING

4.1 Introduction

When you edit your K1200 Programs, you make the instrument truly your own by tailoring its response to your playing style and its sound qualities to your musical taste.

This section covers the basics of editing the K1200, providing the necessary foundation for personalizing your instrument. Once you are familiar with this material, you'll be ready to move on to Part II, the *Programming Reference* and further explore the world that lies "behind the panel" of your instrument.

4.1.1 Voice Structure In The K1200

Figure 4-1 illustrates the hierarchical relationships among the major programming features of the K1200.

Each voice Program originates in a digitally coded waveform, called a **Soundfile**. The Soundfile may be a sampled acoustic sound (such as Fast Strings, Trumpet, and so on) or a digital representation of a basic electronic waveform (a Sine, Sawtooth or Square Wave, for example). The Soundfile is the

primary determinant of the timbre, or sound quality, of the Program.

Soundfiles are assembled into a Program in **Layers** (one Soundfile per Layer). Within each Layer, the assigned Soundfile is treated to add unique characteristics, or to fine-tune its timbre and playing response. Layer treatments consist of **Effects** — which may be either **Compiled** or **Modular** — as well as a number of standard **Layer Parameters**.

A Program may have from one to four distinct, individually-programmed Layers, each of which may be defined to span any portion of the total range of the keyboard. All of the Layers of a given Program are subjected globally to a set of **Program Parameters**, which determine playing characteristics for the Program as a whole.

Finally, every Program in the K1200's memory is subject to a set of **Master Parameters** which determine the overall playing characteristics of the instrument.

4.1.2 The Editing Process

Editing the K1200 is a process of moving among Menus, selecting Parameters within each Menu, and manipulating the Values of those Parameters.

Parameters — A Parameter is an individual programmable function of the K1200 (for example, Master Tuning or Pan). Parameters are selected using the PARAMETER UP and DOWN buttons while in EDIT Mode. By pressing both PARAMETER buttons at once, you can skip to frequently-used Parameters without having to scroll through a long list.

Values — Each Parameter has a Value which determines the way in which the K1200 executes the corresponding function. Most Parameter Values are numerical and, where possible, scaled to musically or technically rational units (tuning Values are in semitones, quartertones or cents, for instance). Figure 4-2 is a list of numerical Value units used by the K1200, along with their abbreviations as they appear in the K1200 display.

* Compiled Effects are preset sound-modifying programs that have been developed by Kurzweil's engineers to simulate various types of standard signal processing, such as Tremolo, Chorus, and Leslie effects. Modular Effects are sound-modifying programs that you design yourself, much as you would with a modular synthesizer. Editing of Modular Effects is covered in Part II of this manual, the *Programming Reference*.

Section IV

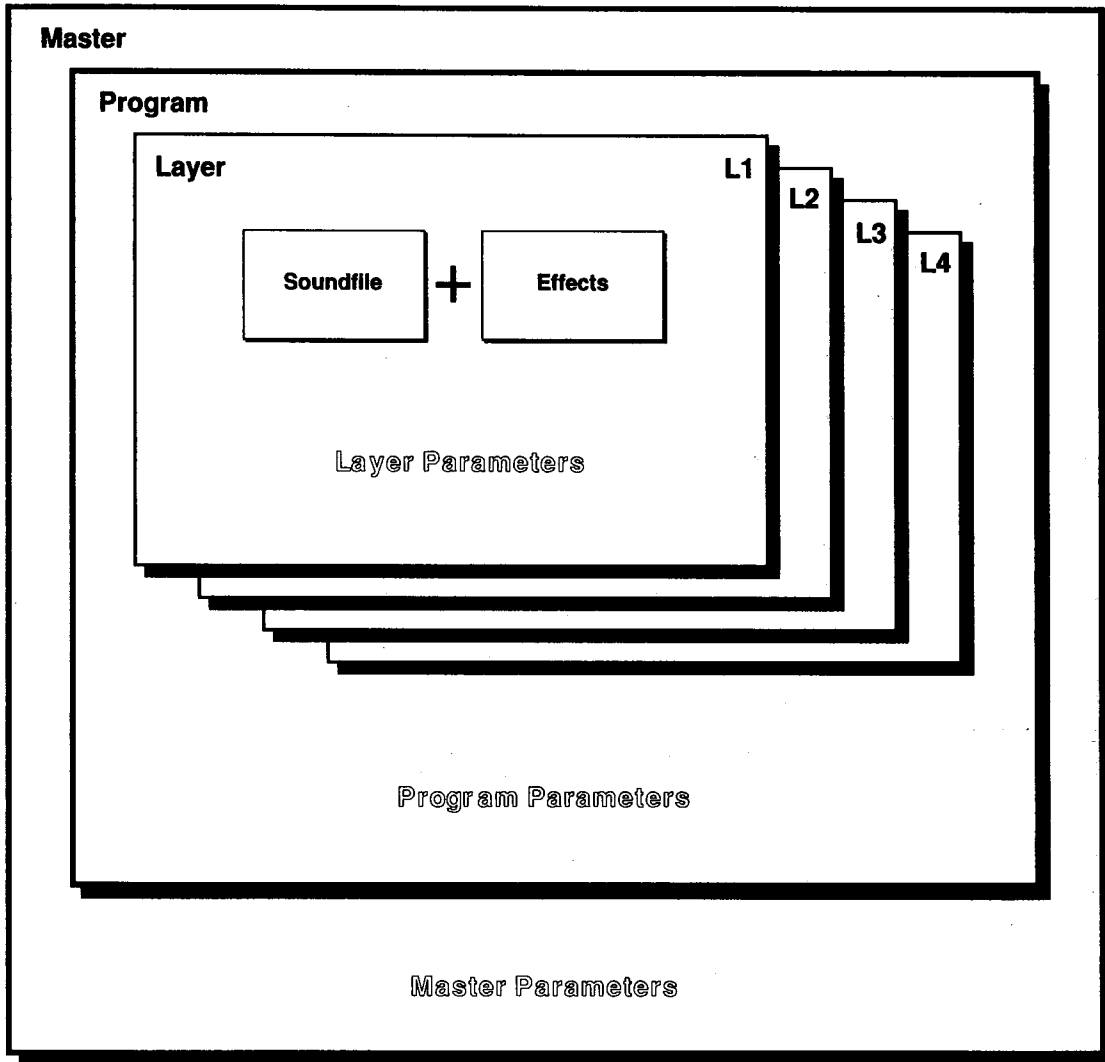

Figure 4-1 K1200 Programming Hierarchy

In some cases, a Value may be expressed as a word (the name of a Soundfile, for instance), or a logical yes/no value (usually a response to a question prompt from the K1200). Values are assigned by pressing the VALUE YES and NO buttons; for numerical Values, YES increases the Value and NO decreases it.

Menus — To make the editing process as convenient and efficient as possible, Parameters with similar or related functions are organized into numbered Menus. The individual Parameters within each Menu are also numbered, and their numbering relates to the Menu number. For example, the sixth Parameter of the Master Menu (which

is Menu number 000) is number 006. Similarly, the sixth Parameter of the Layer Menu (Menu number 200) is number 206.

Navigating — You might visualize the K1200's Parameters as being organized by number into the pages of a book. The MENU buttons move you from one page to another, while the PARAMETER buttons allow you to select specific entries on the currently viewed page.

You can jump from one Menu to another at any time. If you return to a Menu, the Parameter that you selected just before you left it will reappear in the display (as long as you have stayed in Edit Mode).

Instant Feedback — The K1200 remains fully functional and responsive to your control while in Edit Mode. Each change in the Value of a Parameter is quickly entered, so you can hear the effect of your edits by playing the keyboard as you change Values (provided, of course, that the Parameter you modify is assigned to affect the current Program).

None of your changes will be permanent, however, until you save the Program into RAM. Furthermore, it's impossible to erase or permanently replace the ROM-based factory Programs. So, while you can hear the effects of all your edits, you needn't worry about being able to get the original Program back.

Feel free to experiment. When you have the sound you want, you can save it for future use.

Confirmations — Whenever you elect to make an edit that can't be undone (for example, deleting a Program), the K1200 will first ask you "Are you sure?" This gives you a last chance to change your mind; answering YES will cause the edit to be executed. You may turn off the confirmation function, once you become proficient at editing, using Master Parameter 029.

Unit	Display
Semitone	ST
Quartertone ($1/2$ ST)	QT
Cent ($1/100$ ST)	ct
Hertz (cycles per second)	Hz
Percent	%
Decibel	dB
Second	s
Degree	deg
MIDI Velocity	vel

Figure 4-2 Numerical Value Units

Section IV

4.1.3 Entering Edit Mode

To switch from PLAY to EDIT Mode, first select a Program to edit, then press the PLAY / EDIT button. The display should resemble Figure 4-3.

You are now in the Layer Menu. All of the Parameters in this Menu affect the individual Layers of a Program. The upper line of the display gives the current Layer number, the Menu name and the Parameter number. The lower line indicates the name of the current Parameter (Soundfile, in this example) and information associated with that Parameter — in this case, the name of the Soundfile assigned to this Layer.

The only time that you will not see this display upon entering EDIT mode is when you have selected Program 000, a null Program. In this case, only the Master Menu will be available.

By pressing the LAYER button, you can cycle through the Layers of the current Program and identify the Soundfile that is assigned to each one. If the Layer button appears to have no effect, then the Program has only one visible Layer (some Programs contain invisible Layers; see page 30).

The K1200's software has been designed to jump directly to Parameter 206 of the Layer menu because one of the most common (and most powerful) edits that you can make to a Program is to change its assigned Soundfile(s). You can try this now with the current Program: just press the VALUE UP or DOWN button to cycle through all of the Soundfiles. By playing the keyboard as you change Soundfiles, you can hear the effect of your changes. Using this method, you can quickly and easily create new voices.

Each Menu in EDIT Mode has a Parameter which normally appears when you select that Menu. Usually it is a Parameter that you'll be likely to use frequently. This is the Parameter you'll see when you select a given Menu for the first time upon entering EDIT Mode (this could be the first time after powering up, after a reset, or simply when returning to EDIT Mode after exiting to PLAY Mode). If, however, you leave a Menu then return to it **without** leaving EDIT Mode, then you will return to the Parameter which was displayed when you were last in that Menu.

4.1.4 The Compare Function

The Compare function allows you to hear the differences between your Programs before and after editing. To use the Compare function while editing,

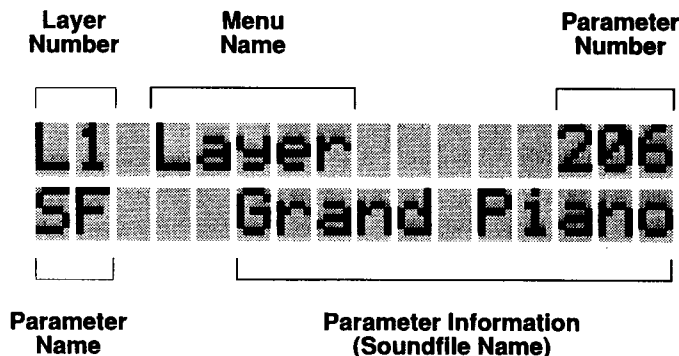

Figure 4-3 Edit Mode Display

simply press [COMPARE] after you have changed some aspect of the currently selected Program. The display will indicate the name and number of the unedited program, and when you strike a key, you will hear the original, unedited Program. Press [COMPARE] again, and the display will return to the normal EDIT mode configuration, showing you the Value for the currently selected Parameter.

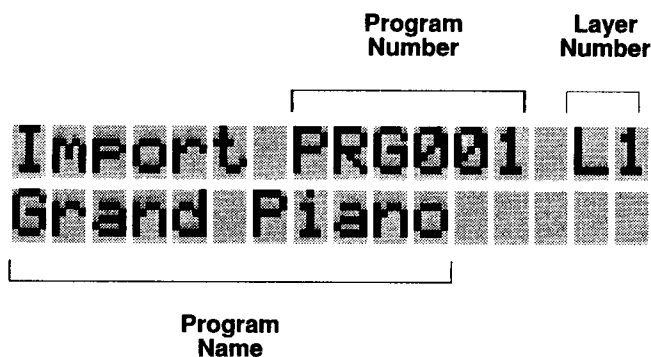

Figure 4-4 Importing a Layer

4.2 Creating Layers & Splits

The techniques of layering voices and creating keyboard splits are among the most powerful and widely-used tools in the synthesist's repertoire. The K1200 accommodates both of these techniques in a few simple editing commands, all of which are within the Layer Menu.

4.2.1 Layered Programs

Layered voices are Programs which play two or more sounds each time a key is pressed.

For example, one very popular layering combination is piano and strings: when the keyboard is played, the instrument produces the sound of a piano doubled by a string section. The effect allows a single accompanist to simulate a large ensemble. This combination is

included as a factory preset on the K1200; it's Program 207, "Piano & Slow Strings."

The K1200's software provides two basic ways to create your own layered Programs. First, you may Import a Layer, along with all of its Effects and playing parameters, from another existing Program into the one that you are editing. (This procedure allows you to use some of the more complex voice setups that come with your K1200 without getting deeply into Modular Effect editing.) Second, you can create a new Layer from scratch.

Getting Started — To create a layered Program, begin in PLAY mode and select a base Program upon which to build. Then switch to EDIT mode and scroll through the Program's Layers

with the LAYER button, so that you know how many Layers are available. (It's easiest to start with a Program having only one Layer, so that you have room to build on.)

Importing a Layer — Once you are sure that there is space to add another Layer, press the PARAMETER DOWN button to get to Parameter 203 of the Edit Menu. The screen display will read:

L1 Layer
203

Import Layer?

Answer YES to the prompt, and the display will resemble Figure 4-4.

The K1200 has jumped to the first Layer of Program 001, the default for importing. From

Section IV

here, you can use the PROGRAM and LAYER buttons to scroll through the available Programs and Layers, trying out different Layers to import. While doing so, you can play the keyboard to hear the effect of your changes.

When you find a layered combination that you like, press YES to confirm your selection. The selected Layer will be added to your current Program, and the display will confirm the operation by showing:

Layer n
Imported

('n' will be the number of the new Layer). You've just created a layered Program. If you want to save it, turn to Section 4.4.2, *Saving Programs*. You can continue importing until you've created four Layers, which is the maximum the K1200 allows. If you have used all available Layers and you try to import another, the K1200 will tell you that no more Layers are available.

Some Compiled Effects require one or two additional "hidden" Layers in order to achieve their effect. These added Layers don't show up when you scroll through the Program with the LAYER button. In some cases, then, you may not have room for another Layer in a Program, even though it may look as though you should. This can occur either because the Pro-

gram has more Layers than are shown in the display, or because the Layer that you wish to import has hidden Layers associated with it. You may be able to circumvent this restriction by selecting different Effects (see Section 4.3).

Creating a New Layer — Adding a new Layer will give you a mostly empty, "fresh" Layer to work with.

Use the PARAMETER buttons to select Parameter 201 of the Edit Menu. The display will read:

L1 Layer 201
New Layer?

Answer YES, and the K1200 will add a new Layer to the current Program. The display will briefly show:

Layer n created

('n' will be the number of the new Layer). The default Soundfile for the new Layer will be Grand Piano, and the Effects Level will be set to Compiled with no Effect selected.

You may now use Parameter 206 to try out various Soundfiles, playing the keyboard to hear the results in each case. Once you have selected a Soundfile and are ready to add Effects to the new Layer, turn to Section 4.3 of this manual. To save the Program, consult Section 4.4.2, *Saving Programs*.

4.2.2 Split Programs

A Split Program is one in which different voices are assigned to different ranges of the keyboard.

For example, in live performance, you might want to be able to play acoustic bass with your left hand and vibes with your right. This would require a keyboard split in which the lower keys are assigned to a bass sound and the upper keys to vibes. The K1200's design easily accommodates splits.

To create a keyboard split, first build a layered Program incorporating the voices that you want to use. Then, use the PARAMETER buttons to select Parameter 209. The display will read:

L1 Layer 209
Set MIDI Range?

Parameter 209 allows you to assign each Layer in a Program to a specific range of keys. Use the LAYER button to select a Layer for editing, then press YES.

The display will prompt you to "Strike 1st key." Press the key on the keyboard that corresponds to one extreme of the range that you want this Layer to cover. The display will ask you to "Strike 2nd key." Press the key corresponding to the other extreme of the desired range.

4.3 Using Compiled Effects

The display will return to the "Set MIDI Range?" prompt. The range of the current Layer now includes the lowest and highest keys that you struck, plus all the notes in between. (Notice that you can strike the keys in any order — lowest first, or highest first.)

You can now select another Layer with the LAYER button and assign it to the range you desire. The ranges of successive Layers can even overlap, if you wish.

Fine Tuning — You can check and adjust the MIDI key range for any Layer using Parameters 210 ("Low Note") and 211 ("High Note"). Each displays the corresponding extreme of the current Layer's key range as a musical note Value (for example, C4 for middle C). Use the LAYER button to scroll through the Layers in your Program, and the VALUE buttons to adjust the range if necessary. The VALUE buttons step in semitone increments; pressing both at the same time will step upward by octaves. In either case, you can press and hold to scroll rapidly through note Values.

Effects are sound-modifying processes that add richness and character to your Programs.

In professional performance and recording, external effects units are almost always used to enhance the sound of electronic instruments. These "outboard" signal processors are powerful tools for making a track more distinctive and increasing its impact. They can also represent a substantial investment for the working musician.

The K1200 incorporates a set of built-in Compiled Effects similar to those of popular outboard processors. Designed by Kurzweil engineers to give you quick access to commonly-used synth effects, these Effects enable you to give your Programs the variety and complexity that contemporary music requires. Most importantly, you can apply different types of Effects separately to each Layer

of your Programs — so you can achieve results that are much more complicated and subtle than those of external effects units.

4.3.1 Selecting Effects

In order to use Compiled Effects, you must make certain that the Effects Edit Level of the Layer that you're working on is set to "Compiled."

In the Layer Menu, select Parameter 215, "Effects." If the current Effects Level is Modular, the display will read:

```
L1 Layer    215
FX          Modular
```

In this case, the current Layer already employs Modular Effects. These Effects contribute to its sound quality. Remember that a single Layer may use only one type of Effect: if you change to Compiled Effects,

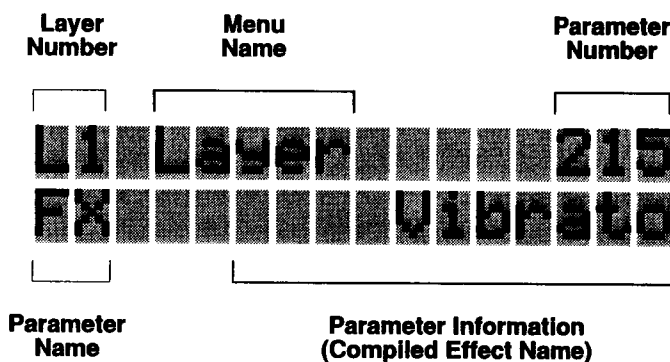

Figure 4-5 Selecting a Compiled Effect

Section IV

you'll lose whatever contribution the Modular Effects provide. This may be fine — the change may not be extreme, and you might discover a new sound in the process. Just be aware that the results may be unexpected.

To change to Compiled Effects, press the appropriate PARAMETER button to select Parameter 216 and answer YES to the "Change Effects Edit Level?" prompt. If Master Parameter 029 ("Confirmation") is set to ON, the K1200 will ask if you are sure. Answer YES, and the K1200 will respond that the Effects Edit Level is changed to Compiled. You can now return to Parameter 215 and select an Effect.

When the current Effects Edit Level is Compiled, the display at Parameter 215 will resemble Figure 4-5. The upper line of the display shows the current Layer number, the name of the Menu (Layer) and the Parameter number (215). The lower line gives the Parameter name (FX) and the name of the currently-selected Effect. If no Effect is selected, the Effect name will be "None."

Use the VALUE buttons to scroll through the list of available Compiled Effects. While you change Effects, you can play the keyboard to hear the results.

When you find an Effect that you like, you can do one of three things:

- Save the current Program as it is (see Section 4.4.2)
- Press LAYER to select the next Layer of your Program and add Effects to it
- Experiment with modifying the current Effect to fine-tune your sound

4.3.2 Modifying Effects

Once you have chosen a Compiled Effect that suits your taste, you can adjust its characteristics using the Parameters in the Effects Menu (#300).

Press one of the MENU buttons to reach Menu 300, then use the PARAMETER buttons to scroll through the available Parameters. You may change the value of any Parameter with the VALUE buttons. Play the keyboard as you change Values to hear the results.

The Effects Menu Parameter list varies depending on which Compiled Effect has been selected. Figure 4-6 summarizes the Parameters for each Compiled Effect. (See also the *Programming Reference*.)

4.4 Naming & Saving Programs

Once you have edited a Program to your satisfaction, you'll want to save it to a RAM location so that you can recall it when you need it.

If you've already made some basic edits and tried switching back to PLAY Mode, you know by now that the K1200 automatically gives you a chance to save an edited Program when you exit EDIT Mode. The series of dialogs that it takes you through is exactly the same as that described in Section 4.4.2, *Saving Programs*. This feature is very useful if you are editing "on the fly" and want to get back into PLAY Mode quickly, but it bypasses the step of renaming the Program.

The K1200's software also offers a more thorough and orderly way of manipulating Programs in memory, allowing you to give each Program a unique name and then save it without leaving EDIT Mode. All of the commands that are involved are found in the Program Menu (Menu 100).

4.4.1 Naming Programs

While the K1200 keeps track of Programs by number rather than name — and, in fact, allows you to have two or more Programs with the same name — you'll find it much easier to keep your Programs organized if you get into the habit of naming

Vibrato		Vibrato / Chorus 2*	
[301]	Maximum Depth	[301]	Maximum Rate
[302]	Maximum Rate	[302]	Maximum Depth
[303]	Shape	[303]	Shape
[304]	Depth Control	[304]	Rate Control
[305]	Rate Control	[305]	Depth Control
		[306]	Transpose
Delay Vibrato		[307]	Detune
[301]	Maximum Depth	[308]	Delay
[302]	Maximum Rate	[309]	Enable
[303]	Shape	[310]	Pan 1
[304]	Delay	[311]	Pan 2
[305]	Ramp		
[306]	Rate Control		
		Phaser 2*	
Tremolo		[301]	Maximum Rate
[301]	Maximum Depth	[302]	Depth
[302]	Maximum Rate	[303]	Ramp
[303]	Shape	[304]	Shape
[304]	Depth Control	[305]	Rate Control
[305]	Rate Control	[306]	Detune
		[307]	Delay
Delay Tremolo		[308]	Pan 1
[301]	Maximum Depth	[309]	Pan 2
[302]	Maximum Rate		
[303]	Shape	Leslie 2*	
[304]	Delay	[301]	Rate
[305]	Ramp	[302]	Depth
[306]	Rate Control	[303]	Ramp
		[304]	Trigger
Leslie		[305]	Pan 1
[301]	Rate	[306]	Pan 2
[302]	Depth		
[303]	Ramp	Chorus 3*	
[304]	Trigger	[301]	Transpose
		[302]	Detune
Chorus 2*		[303]	Delay
[301]	Transpose	[304]	Enable
[302]	Detune	[305]	Pan 1
[303]	Delay	[306]	Pan 2
[304]	Enable	[307]	Pan 3
[305]	Pan 1		
[306]	Pan 2	Echo 3*	
		[301]	Delay
Tremolo 2*		[302]	Decay
[301]	Maximum Rate	[303]	Enable
[302]	Maximum Depth	[304]	Pan 1
[303]	Shape	[305]	Pan 2
[304]	Rate Control	[306]	Pan 3
[305]	Depth Control		
[306]	Pan 1		
[307]	Pan 2		

*Uses additional "invisible" Layers.

Figure 4-6 Parameters of the Effects Menu

them before you save them. To name or rename a Program, press one of the MENU buttons to get to the Program Menu (100), then press the PARAMETER UP button to select Parameter 101. In answer to the prompt "Name Program?" press the VALUE YES button.

The display should now resemble Figure 4-7. The bottom line of the display shows the current Program name. An underscore cursor appears beneath the first letter of the name, indicating that the K1200 is prepared to accept changes to that character.

The K1200's front-panel buttons take on special editing functions in the naming sequence, as shown in Figure 4-8.

PLAY / EDIT — Pressing the PLAY / EDIT button deletes the character above the cursor. All characters to the right of the cursor will move one position to the left.

LAYER — Pressing the LAYER button inserts a space at the cursor location. The character above the cursor (and all the characters to the right of it) will move one position to the right.

MENU UP and DOWN — The MENU buttons serve as cursor controls. MENU UP moves the cursor to the right, while DOWN moves it to the left. Pressing both MENU buttons at once

4.4.2 Saving Programs

Once you have named your Program, press the PARAMETER UP button to select Parameter 102. The K1200 will respond with the prompt, "Save Program?"

If you answer YES to the "Save Program?" prompt, one of two things will happen. If you began by editing a preset (ROM) Program, the K1200 will display the next available RAM Program ID# (starting at #255 and moving *downward*) and will suggest that your Program be given that ID# and that it be stored at the Program number displayed at the left of the LCD. If you began by editing a RAM Program, the K1200 will ask you if you want to replace the displayed Program. Use the PROGRAM buttons to select a different ID# if you wish.

Answering YES again will cause the K1200 to save the Program with the ID# and Program number assigned as displayed. (If you answer NO instead, at this point, the K1200 will ask you if you want to discard your changes. YES will abort the save. NO will return to the Save Prog? prompt.)

When you save a Program, then after a second or so, the display will ask you if you want to update the Program List. The upper line of the display will show you the previously se-

lected Program number (the one you had selected before you entered EDIT Mode), and the ID# assigned to it. If you answer YES, the K1200 will automatically map the ID# of the new Program to the displayed Program number. This gives the new Program the Program number of the old, unedited Program, and removes the old Program from the current Program List. If you answer NO, the K1200 will assign the new Program to the next available User Program number (they begin with Program number 401).

You'll want to update the PList when you've made adjustments to Programs you've been using, and plan to keep using after you've made the adjustments. If, on the other hand, you've created an entirely new, significantly different Program, you probably won't want to update the PList. You can always reassign the Program number later by editing the PList.

If this is unclear to you, the example in Section 6.6 will help.

The number of Programs you can create and save depends on their complexity. Once the K1200's memory is full, you won't be able to save any additional Programs without erasing existing ones. If you have ObjectMover,[™] you can avoid this limitation by saving

Programs and other Objects to disk. See Section 5.2.

It's possible to save RAM Programs to the ID#s of the K1200's ROM (preset) Programs. If you do this, the new Program will "overwrite" the older ROM Program. This does not erase the ROM Program, but "hides" it "behind" the RAM Program. If you delete the RAM Program, the ROM Program will "reappear."

4.4.3 Deleting Programs

Deleting a Program (or any other Object) should be done with care, because once it's deleted, it's gone forever unless you have a backup. To delete a Program, simply answer YES to Parameter 103. If Parameter 029 is set to On, the K1200 will ask you if you are sure you want to delete the Program. If you answer YES again, the Program will be deleted. Answer NO to cancel the deletion sequence.

Section IV

4.5 Monophonic Output Setting

There may be occasions when you won't be able to take advantage of the K1200's stereo output capability.

Your present sound system may have only one input, for example. Or you might be undertaking a particularly complex project with a lot of sound sources, and need to free up every channel of your mixer that you can spare. Under these circumstances, if you connect just one of the K1200's two outputs, you will lose some proportion of the sound of every stereo Program unless you set the K1200 for monophonic output.

To do so, use the MENU buttons to reach the Master Menu (number 000), then press the PARAMETER UP button to

select Parameter 020, "Mono Output." The display will look like Figure 4-9.

The upper line of the display shows the current Layer number, the Menu name (Master) and the Parameter number. On the lower line is the Parameter name and default Value, OFF.

You may use either VALUE button to toggle the Value on and off. A Value of ON will cause the K1200 to add its two audio channels and output the sum at both Output connectors, overriding all Pan settings of every Program. Note that this does not *erase* any Pan settings, however.

To restore stereo output capability, set this Parameter to OFF.

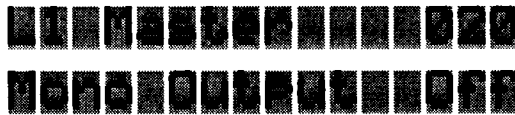

Figure 4-9 Setting the K1200 for Monophonic Output

4.6 Advanced Program Editing

Now that you are familiar with the basic principles of editing — accessing Parameters within Menus, changing their Values, and saving the results as a new Program — you have the skills to begin getting into advanced editing procedures.

At the advanced level, you'll start from scratch with a digital emulation of a traditional modular music synthesizer, putting together building-block elements to create Modular Effects. (The Compiled Effects that you've been working with were actually built using this same technique, and can be studied as examples of Modular Effect editing.) Advanced editing also gives you more control over the playing response of the K1200, allows you to explore alternate tuning systems, and permits extensive control over MIDI functions.

Advanced editing is covered in Part II, the *Programming Reference*. When you're ready to explore advanced Program editing, we recommend that you set aside some time to study the *Programming Reference* carefully. You'll find that time spent at the outset to gain a clear overview of the K1200's software will pay off later in the efficiency of your work and the quality of your Programs.

Have fun!

Part II

Programming Reference

Section V

INTRODUCTION

5.1 About This Manual

This section of the manual has been designed to provide you with all of the information you will need to program your new K1200.

Section V introduces basic programming concepts and software features of the 1000 Series. This information is essential to understanding the following sections.

Section VI covers the Master Menu and its submenus. The Parameters of these menus affect all Programs, and determine general playing characteristics of the instrument.

Section VII presents the Program Menu, whose Parameters affect Programs individually.

Section VIII covers the Layer Menu. The Parameters of this Menu separately determine the characteristics of each Layer in a Program.

Section IX presents editing of Modular Effects, which represent the digital equivalent of a traditional modular synthesizer. The Parameters of the Modular Effects Menus provide very fine control of a Program's timbre.

Section X contains programming examples that are designed to demonstrate practical applications of the K1200's EDIT Mode.

Section XI is a quick-reference guide for use in programming the K1200. Charts and illustrations from both this part and from Part I, the *Performance Guide* are reproduced together here, so that you can find them quickly and easily. This Section also contains supplementary information that is not covered elsewhere in the manual.

Section XII, the Appendix, provides information on Value resolutions in the K1200 and describes self-diagnostic routines for the K1200. These routines can be very helpful if you suspect a malfunction in your instrument.

Important: *Entering the diagnostics will erase the K1200's RAM. Don't use them if you don't have a way to avoid losing the results of your programming.*

Also included in the appendix is technical information on interfacing your K1200 with the "outside world." If you are making your own cables, or if you plan to use your K1200 in professional performance and recording studios, you'll want to refer to this section. Finally, you'll find detailed technical specifications for the K1200.

Part One of this manual, the K1200 *Performance Guide* contains important basic information about your new

instrument. If you have not already done so, please take time to familiarize yourself with that section before proceeding through this *Programming Reference*.

5.2 1000 Series Objects

At many points in this manual, you will see references to Objects.

"Object" is a generic term which refers to programming features of 1000 Series instruments: items which can be named, saved, deleted, defined or programmed are termed Objects. Programs, Velocity Maps and Intonation Tables, for example, are Objects. So are the Effects Modules that are discussed in Section X of this manual.

Having already studied your *Performance Guide*, you are familiar by now with the procedures for naming, saving and deleting Programs. Similar procedures apply in the case of some other Objects: Velocity Maps (programmed features that define how the K1200 responds to MIDI Velocity data), MIDI Program Maps (which determine both the transmission and reception of MIDI Program Change data), and Intonation Tables (which permit special tuning systems such as Just Intonation) are all treated in the same way.

5.3 The Editing Menu System

In addition to using the programming features of your K1200, you can also manipulate Objects with ObjectMover™, an application developed by Kurzweil for popular personal computers. ObjectMover is a basic patch librarian program, enabling you to move 1000 Series Objects between two or more 1000s, and to program your 1000 from your computer screen. It also enables you to save Objects to disk in Library files.

ObjectMover is available for the Macintosh computer (512K RAM or more) and the Atari ST (520 or 1040). An IBM-compatible version is currently under development.

As described in Section IV of your *Performance Guide*, the K1200's EDIT Mode Parameters are grouped into Menus for convenient and efficient editing.

The first Parameter of each Menu is the name, or heading, of that Menu. All Menu heading numbers end in "0." Values are not assignable to Menu headings, so no Value or unit of measurement appears in the lower line of the display when a heading is shown. You can usually select the Menu heading or the first programming Parameter in a Menu with one or more dual presses of the PARAMETER buttons.

The system of Menus available for editing varies depending upon the current Effects Edit Level of the current Layer. When Compiled Effects are selected, for example, the Menu associated solely with Modular Effects editing will not appear in the display. Similarly, when Modular Effects are selected, Menu number 300 (the Effects Menu, which contains Compiled Effects Parameters) cannot be accessed.

Figure 5-1 summarizes the Edit Mode Menus that are available for each Effects Edit Level.

000	MASTER
100	PROGRAM
200	LAYER
300	EFFECTS (Compiled Effects only)
700	Amp ENV (Amplitude Envelope 1)
900	ENV Ctl (Envelope Control)

(a) Compiled Effects Selected

000	MASTER
100	PROGRAM
200	LAYER
410	LFO1 (Local Low Frequency Oscillator 1)
420	LFO2
430	gLFO1 (Global LFO1)
440	gLFO2
510	ASR1 (Local Attack-Sustain-Release Envelope 1)
520	ASR2
530	gASR1 (Global ASR1)
540	gASR2
600	MXR (Mixer)
650	INV/NEG (Inverters and Negators)
700	Amp ENV (Amplitude Envelope 1)
800	ENV2 (Envelope 2)
900	ENV Ctl (Envelope Control)
920	Pitch Ctl (Pitch Control)
940	Amplitude Ctl (Amplitude Control)

(b) Modular Effects Selected

Figure 5-1 The Edit Mode Menus

Section V

5.4 About Control Sources

As you work through this *Programming Reference*, you will often see "Control Source List" given as the Value for a Parameter. The K1200 enables you to use a large number of internal and external Control Sources to modify dynamically the Values of Parameters and the functions of Effects Modules.

Mod wheels, footswitches and breath controllers are examples of Control Sources. MIDI data from a master keyboard, such as afterpressure, attack velocity and so on, also are Control Sources. The complete 1000 Series Control Source List is shown in Figures 5-2a and 5-2b (pages 41 and 42).

The assignment of Control Sources is an extremely powerful programming tool in the 1000 Series software. Notice that the Control Source List is very extensive. The K1200 has been designed to offer maximum versatility and flexibility in programming. A wide variety of sonic and musical functions is easily achieved simply by navigating through the Edit Menus and systematically assigning Control Sources to various Parameters.

Naturally, some Control Sources will be logical choices for certain Parameters, but not for others. In general, Control Sources appear in the display as possible Values for a Para-

meter only if they can actually be used to control that Parameter.

5.4.1 Control Source Configuration

Control Source data are expressed within the 1000 Series as a number between -1 and +1. The *configuration* of a Control Source determines how its output signal varies within that range. A given Control Source may have a unipolar, bipolar, or logical configuration.

Unipolar Control Sources generate signals ranging from 0 to +1.

Bipolar Control Sources generate signals between -1 and +1.

Logical Control Sources are Unipolar Sources whose signal values are limited to 0 and +1, with no intermediate values.

For example, the Sustain Pedal is a Logical Control Source: it generates +1 when the pedal is pressed down, and 0 when it is released.

A slider (such as the Volume or Data Entry slider) is Unipolar: it generates 0 at minimum, +1 at maximum, and +0.5 at its midpoint. The Mod Wheel Control Source is also Unipolar, generating 0 when the wheel is at center and +1 at either extreme.

Many of the K1200's Effects Modules are Bipolar. The Low Frequency Oscillators, for instance, generate waveshapes which vary between -1 and +1 (LFOs also can be made unipolar; see Section 9.2).

5.4.2 Control Source Type

The K1200 provides two *types* of Control Sources: local and global.

Global Control Sources affect every note that is generated by a given Program, with all notes receiving the same control signal. The MIDI Pitch Wheel is an example of a Global Control: if you hold two notes and move the Pitch Wheel, both notes will be bent equally at the same time and in the same direction.

Local Control Sources affect each note individually. Even when played at the same time, multiple notes each receive their own Local Control signals. MIDI polyphonic afterpressure is an example of a Local Control Source.

5.4.3 Descriptions of Control Sources

Please refer to Figure 5-2, the Control Source List, throughout this discussion.

None — Indicates that no Control Source has been assigned to the currently selected Parameter. When you create

Name	Display	Config	Type
Off	OFF	Logical	Global
On	ON	Logical	Global
None	None	—	—
Modulation Wheel (MIDI 01)	M Wheel	Unipolar	Global
Breath Controller (MIDI 02)	Breath		
MIDI 03	MIDI 03		
Foot Switch (MIDI 04)	Foot		
Portamento Time (MIDI 05)	PortTim		
Data Entry (MIDI 06)	Data		
Volume (MIDI 07)	Volume		
Balance (MIDI 08)	Balance		
MIDI 09	MIDI 09		
Stereo Pan (MIDI 10)	Pan		
Expression (MIDI 11)	Express		
MIDI 12	MIDI 12		
MIDI 13	MIDI 13		
MIDI 14	MIDI 14		
MIDI 15	MIDI 15		
Performance Control A (MIDI 16)	Ctl A		
Performance Control B (MIDI 17)	Ctl B		
Performance Control C (MIDI 18)	Ctl C		
Performance Control D (MIDI 19)	Ctl D		
MIDI 20	MIDI 20		
MIDI 21	MIDI 21		
MIDI 22	MIDI 22		
MIDI 23	MIDI 23		
MIDI 24	MIDI 24		
MIDI 25	MIDI 25		
MIDI 26	MIDI 26		
MIDI 27	MIDI 27		
MIDI 28	MIDI 28		
MIDI 29	MIDI 29		
MIDI 30	MIDI 30		
MIDI 31	MIDI 31		
Sustain Pedal (MIDI 64)	Sustain		
Portamento Switch (MIDI 65)	Port Sw		
Sostenuto Pedal (MIDI 66)	Sost Pd		
Soft Pedal (MIDI 67)	Soft Pd		
MIDI 68	MIDI 68		
Freeze Pedal (MIDI 69)	Frez Pd		
MIDI 70	MIDI 70		
MIDI 71	MIDI 71		
MIDI 72	MIDI 72		
MIDI 73	MIDI 73		
MIDI 74	MIDI 74		
MIDI 75	MIDI 75		
MIDI 76	MIDI 76		
MIDI 77	MIDI 77		
MIDI 78	MIDI 78		
MIDI 79	MIDI 79		

Figure 5-2(a) 1000 Series Control Source List

new Effects Modules, they usually default to this Value, which is equivalent to Off.

OFF — This is a constant Control Source value of 0. It is usually used to turn something off, or to hold a Parameter at its minimum value.

ON — This is a constant Control Source value of +1. It may be used to turn something on, or to hold a Parameter at its maximum value.

MIDI 01-31 & 64-95 — Many MIDI Control Numbers (often called Destinations) are standardized for certain functions by the MIDI 1.0 Specification that manufacturers use as a guideline for their MIDI implementation. MIDI 07, for example, is normally associated with Volume.

Unlike most synthesizers, which ordinarily feature pre-programmed MIDI Control Number assignments that cannot be changed, the K1200 offers full flexibility in its MIDI implementation. Parameters requiring Control Sources can be assigned to be controlled by almost any MIDI Control Number from 1-31 or 64-95. Control Numbers 1-31 are intended for use with continuous controllers like Volume. Control Numbers 64-95 are for use with switch controllers like a Sustain pedal.

Section V

Control Numbers 33–63 are reserved for use as the LSB (Least Significant Byte) for destinations 1–31, respectively. This allows greater resolution in the K1200's processing of control signals.

The Reference Section (Section XI) of this manual includes a list of the Control Numbers whose functions are standardized by the MIDI 1.0 Specification. Refer to the documentation of your master controller for information regarding its MIDI implementation.

Pitch Wheel — The Pitch Wheel Control Source generates -1 when the MIDI controller's Pitch Wheel is at one extreme, and +1 at the other. The polarity (+ or -) of the value relative to the wheel's position (up or down) depends on the setting of the Bend Range Parameter (number 224, in the Layer Menu) for each Layer of the Program.

Monophonic Pressure — If you want one of your K1200's Parameters to be controlled by the Monophonic (channel) afterpressure from the keyboard, assign this Control Source to that Parameter.

Polyphonic Pressure — Allows you to apply afterpressure signals on an individual basis to single notes (providing that you use a MIDI controller which will transmit this data).

Name	Display	Config	Type
Performance Control E (MIDI 80)	Ctl E	Unipolar	Global
Performance Control F (MIDI 81)	Ctl F		
Performance Control G (MIDI 82)	Ctl G		
Performance Control H (MIDI 83)	Ctl H		
MIDI 84	MIDI 84		
MIDI 85	MIDI 85		
MIDI 86	MIDI 86		
MIDI 87	MIDI 87		
MIDI 88	MIDI 88		
MIDI 89	MIDI 89		
MIDI 90	MIDI 90		
MIDI 91	MIDI 91		
MIDI 92	MIDI 92		
MIDI 93	MIDI 93		
MIDI 94	MIDI 94		
MIDI 95	MIDI 95		
Pitch Wheel	P Wheel	Bipolar	Global
Monophonic Afterpressure	M Press	Unipolar	Global
Polyphonic Afterpressure	P Press	Unipolar	Local
Attack Velocity	Att Vel	Unipolar	Local
Release Velocity	Rel Vel	Unipolar	Local
Note State	Note St	Logical	Local
Key State	Key St	Logical	Local
Key Number	Key Num	Unipolar	Local
Local LFO 1 Output	LFO1	Bipolar	Local
Local LFO2 Output	LFO2	Bipolar	Local
Local LFO1 Phase	LFO1ph	Bipolar	Local
Local LFO2 Phase	LFO2ph	Bipolar	Local
Global LFO1 Output	gLFO1	Bipolar	Global
Global LFO2 Output	gLFO2	Bipolar	Global
Global LFO1 Phase	gLFO1ph	Bipolar	Global
Global LFO2 Phase	gLFO2ph	Bipolar	Global
Local ASR1 Output	ASR1	Unipolar	Local
Local ASR2 Output	ASR2	Unipolar	Local
Global ASR1 Output	gASR1	Unipolar	Global
Global ASR2 Output	gASR2	Unipolar	Global
Mixer 1 Output	MXR1	Bipolar	Local
Mixer 2 Output	MXR2		
Inverter 1 Output	INV1		
Inverter 2 Output	INV2		
Negator 1 Output	NEG1		
Negator 2 Output	NEG2		
Amplitude Envelope	Amp ENV	Unipolar	Local
Envelope 2	ENV2	Bipolar	Local
Velocity Trigger 1	VTrig1	Logical	Local
Velocity Trigger 2	VTrig2	Logical	Local
Inverted Attack Velocity	InvAVel	Unipolar	Local
Inverted Release Velocity	InvRVel	Unipolar	Local
Playback Rate	PB Rate	Unipolar	Local
Absolute Pitch Wheel	Abs P-Whl	Unipolar	Global
Bipolar Mod Wheel	Bi M-Whl	Bipolar	Global
Channel State	Chan St	Logical	Global

Figure 5-2(b) 1000 Series Control Source List

Attack Velocity — This Control Source causes a Parameter or Module to be controlled by the MIDI Attack Velocity of a given note.

The value generated by this Source depends not only on how hard you strike your K1200's (or other MIDI controller's) keys, but also on which Velocity Map you have selected in the Master Menu. Values tend toward +1 with hard strikes, and toward 0 with soft strikes. A MIDI Attack Velocity signal is sent with each Note On message, and is translated into a dynamic level through the Master Velocity Map.

Keystrike Dynamic	Attack Velocity
fff	1.0
ff	0.9
f	0.8
mf	0.6
mp	0.4
p	0.2
pp	0.1
ppp	0.05

Figure 5-3 Approximate Attack Velocity Values

The table of Figure 5-3 shows the relationship between the force of your keystrikes and the approximate value generated by this Control Source.

Release Velocity — The MIDI Release Velocity signal is transmitted with each Note Off message, and is processed similarly to the Attack Velocity signal. The value of this Control Source will be 0 until a Note Off message is received.

Note State — This logical Control Source is directly related to the on/off state of the current note. It will be +1 (On) as long as the key that triggered the note is pressed or the note is sustained by the sustain, sostenuto, or freeze pedal

functions. The value will be 0 (Off) if the key is released with no sustaining functions activated, or when the sustaining function is released.

Key State — This Source is similar to Note State, but is related only to the actual key that triggers a given note. When the key is pressed, it will generate a value of +1 (On); when the key is released, it will generate a value of 0 (Off) *regardless of whether a sustain function has been activated.*

Key Number — This Source's value is 0 when the lowest key of the related Layer is played, and +1 when the highest key of the Layer is played. Values for keys in between are interpo-

lated linearly between 0 and +1. For example, if the low note of a Layer is C4 (middle C) and the high note is C8, then playing middle C will cause the Key Number Control Source to generate a value of 0; C8 will generate +1; and C6 will generate +0.5 (See Section VIII, Parameters 209–211).

Inverse Attack Velocity — This is an inverted version of Attack Velocity. The value of this Control Source is equal to +1 minus the Attack Velocity.

Inverse Release Velocity — Similar to Inverse Attack Velocity, the value of this Source is equal to +1 minus the value of Release Velocity.

Section V

Playback Rate — This is a complicated Control Source that depends on the playback rate of the root sample associated with the currently-played note.

A K1200 Soundfile is actually a collection of several root samples, and transpositions of each of them, distributed in regions across the keyboard. Each root has a different playback rate, as does each of the notes associated with that root.

This Control Source generates a signal approaching zero as the playback rate of the current note nears the minimum for its region, and approaching +1 as the playback rate nears maximum. Seemingly random variations between 0 and +1 can be attained using this Source.

Effects Modules — This group of Control Sources (LFOs, ASRs, Mixers, Inverters and Negators) consists of Kurzweil 1000 programming Modules. All are explained in Section IX.

LFO Phase (for each of LFO 1 and 2, and gLFO 1 and 2)— The "phase" of an LFO is given in degrees, with 360 degrees representing one complete cycle of the LFO. This control source linearly converts the current phase of the LFO into a control signal of ± 1 . $0^\circ = -1$, $359^\circ = +1$. Turn to section IV of your *Performance Guide* for a refresher on the K1200's interpretation of control signals. These Control Sources appear in the Control Source List as LFO1ph, LFO2ph, gLFO1ph, and gLFO2ph.

Channel State (Chan St in Control Source List)—A simple On/Off control, Channel state is On when *any* note is triggered or held by the keyboard or a control. This Control Source is useful for triggering global ASRs, or for selecting between layers (used in conjunction with Layer Enable and Enable Sense) for legato response.

Absolute Pitch Wheel Value (Abs P-Whl in Control Source List)—When the pitch wheel is at center, the value of this Control Source is 0. The value progresses linearly from 0 to 1 as you deflect the pitch wheel in either direction (maximum pitch wheel deflection gives a value of 1). Use this Control Source to trigger an effect any time you bend pitch.

Bipolar Mod Wheel Value (Bi M-Whl in Control Source List)—Like Abs P-Whl, the value of this Control Source is linked to the deflection of the Mod Wheel on your MIDI controller. Bi M-Whl is bipolar, however, which means that it sends a value of 0 with the Mod Wheel at center, -1 with the Mod Wheel at minimum, and +1 with the Mod Wheel at maximum.

5.5 Reading The Next Sections

Sections VI through X of this manual are devoted to explaining the functions of all of the Parameters in each of the Edit Mode Menus. These Sections are organized somewhat like a dictionary, with the Parameters of each Menu treated in strict numerical order.

At the beginning of each Menu Section, you will see a flowchart that summarizes the Parameters within that Menu and their relationships to one another. The chart also indicates which Parameters you can jump to with a dual press of the PARAMETER buttons. (In the text, these Parameters are numbered in outline type.) Refer to the flowchart when you are reading through the Section.

In the text, each individual Parameter description is headed as shown in Figure 5-4 (we have used Parameter number 208 as an example).

The Parameter number is followed by the name (often abbreviated) of the Parameter. For example, the name of Parameter 208 appears as "Kbd Tilt."

The black "bullet" item gives the range of possible Values for the Parameter—in this case, ± 48 dB. If the Parameter can take several distinct Values, they are listed sequentially as they will appear in the display with repeated presses of the VALUE UP button.

The white bullet item tells you how the Parameter is affected by a dual press of the VALUE buttons (here, a dual press moves to the next highest multiple of 6 dB). When a dual press of the VALUE buttons is not recognized, the white bullet item is omitted.

As you can see, the material has been organized to make it as easy as possible for you to find the information that you need when programming your K1200. We recommend, however, that you read through all of the text once, in order to gain familiarity with the programming principles of the instrument's software and the range of capabilities at your command.

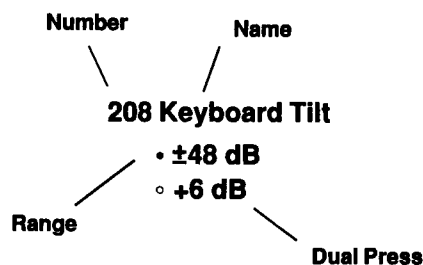

Figure 5-4 Format for Parameter Headings

Section VI

MASTER MENU

The Parameters in the master Menu affect all of the K1200's sounds—unlike the Program Menu Parameters, for example, which affect only the Program whose Parameters you change.

The Master Menu is always available, even if you have selected Program 000. Values for all Master Parameters are preserved when you turn off your K1200 (except Local Control, which always returns to "On").

000 Master

This is the Menu heading.

001 Edit Channels •Yes

You'll need to use this Parameter only when your K1200 is receiving MIDI data from another controller, or a sequencer. It enables you to set independent performance specifications for each MIDI channel—volume levels during mixdown, for example. When you answer Yes to this Parameter, you will move to a special list of Channel Editing Submenus for each MIDI channel (see Section 6.1).

The Channel Editing Submenu Parameters, when modified, will override all corresponding Layer assignments, enabling you to maintain performance characteristics for a particular MIDI channel even when you change the Program assigned to it.

002 Reset Channels

- Yes

Enables you to clear all changes you have made with Parameter 001. If you answer YES to this Parameter, you will disable all of the Channel Parameters, returning control to the Layer Parameters of each Program. You'll receive one or more warnings about the loss of data when you answer YES to this Parameter.

003 Transmit Program Change (Xmit Prg Chg in display)

- On
Off
Extended (Ext)

This Parameter determines how the K1200 sends Program Change messages from its MIDI Out port when you select a Program from its front panel—using any of the three methods: PROGRAM buttons, ENTER and numeric buttons, or Bin Banks. This Parameter also affects Program Change messages sent when a PSetup is selected.

With Parameter 003 set to On, the K1200 will send a Program Change message with the same Value as the Program you select—for Program Change numbers from 0 - 99. The K1200 will simply ignore the hundreds digit in Program change numbers of 100 or

higher, sending the lowest two digits only. For example, selecting Program number 121 would result in Program number 21 being sent from the K1200's MIDI Out port.

Use one of the VALUE buttons to set this Parameter to Off if you want to change Programs from the K1200's front panel without sending Program Change messages to connected MIDI devices.

Select a Value of Extended (the default) when you are using the K1200 to control other Kurzweil keyboards or expanders with Version 5 software. You also will want to use the Extended setting when recording to a sequencer that you will use to control the K1200 (or other v5 Kurzweil 1000s or 1200s) on playback. A Value of Extended enables the K1200 to send the "extended" Program Change messages that simplify Program mapping with the K1200 (please see the separate discussion of Extended Program Changes on page 52).

004 Receive Program Change (Rcv Prg Chg in display)

- On
Off
Extended

The Master Menu

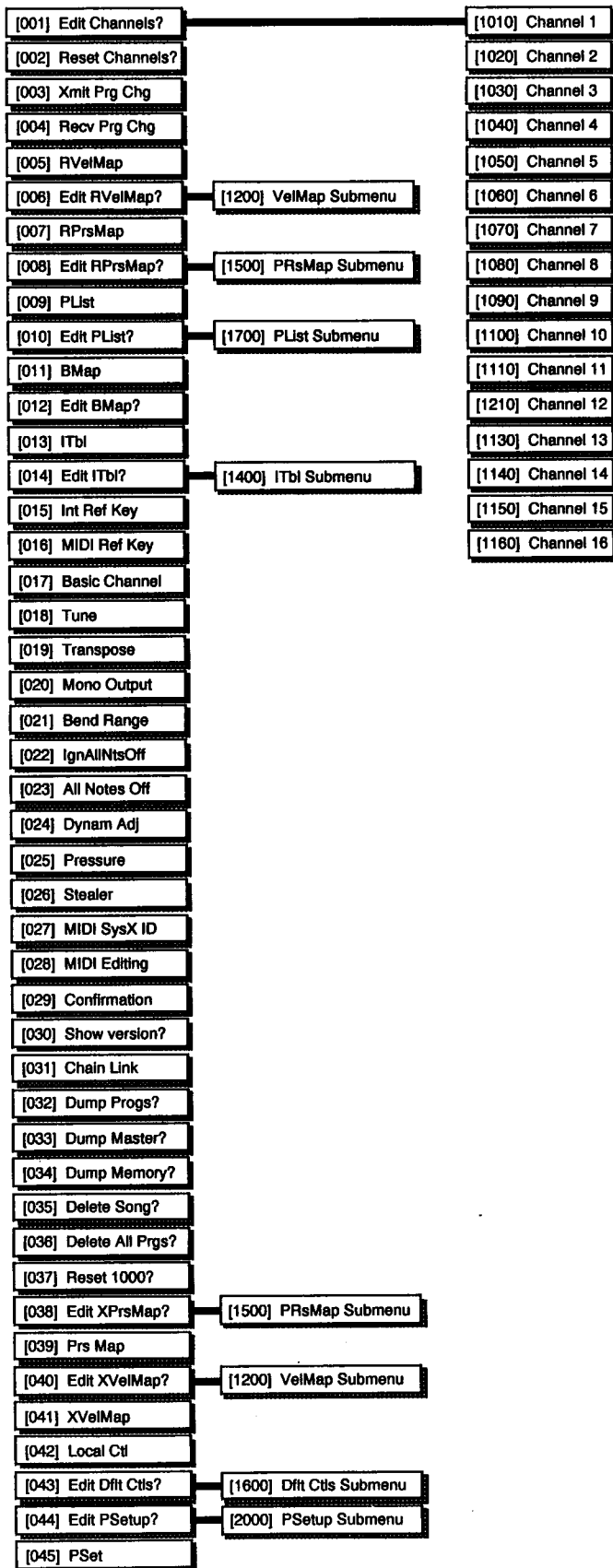

Section VI

Use this Parameter to determine how the K1200 will respond to Program Change messages sent from connected MIDI devices.

The default Value is Ext. Use either of the VALUE buttons to change the Value to Off if you do not want the K1200 to receive Program Change messages.

Select a Value of Extended when the K1200 will be receiving "extended" Program Change messages from another MIDI device. See the discussion of Extended Program Changes on page 52 if you need further information.

005 Receive Velocity Map (RVelMap in display)

- Hardest
- Harder
- Hard
- Medium
- Easy
- Easier
- Easiest
- DX7 Hard
- DX7 Medium
- DX7 Easy
- Linear

Velocity Maps determine the relationship between keystrike velocity and the dynamics (loudness) and brightness of the sound produced by the K1200. Different Velocity Maps allow you to customize the dynamic

response of the K1200 to different MIDI controllers and playing styles.

This Parameter is important only if your K1200 is the MIDI Slave for another MIDI device (the other device's MIDI Out port is connected to the K1200's MIDI In port). In this case, the K1200's dynamics will change as you select different Receive Velocity Maps.

In general, the "harder" the setting, the more velocity the K1200 will require to achieve maximum dynamic levels. The "easier" the setting, the less velocity required to reach full dynamics.

Velocity Maps also may be edited, renamed and saved in non-volatile RAM. You'll want to select different VelMaps for use with different MIDI controllers or playing styles. See Parameters 006 and 1200 through 1212 (Section VI) for more information.

006 Edit Receive Velocity Map

- Yes

Answering YES to this Function Parameter will take you to the Velocity Map Submenu (See Section 6.2). You then will be able to edit the currently selected Velocity Map. (Be sure to select the Velocity Map you wish to edit **before** editing.)

007 Receive Pressure Map (RPrs Map in display)

- Linear
- Low Bias
- Easier
- Easiest
- Dual Switch

This is another Parameter that is important only when your K1200 is receiving MIDI information from some kind of MIDI controller. The K1200 will respond to both monophonic (channel) and polyphonic (key) pressure (aftertouch). This Parameter enables you to select different pressure maps, thus modifying the K1200's response to pressure messages from your MIDI controller.

Your ears will give you the best comparison among the various pressure maps, but in general, the Linear map provides a consistent increase in effect as you increase the pressure. The Low bias setting will give you a greater initial effect with less pressure, tapering off as you add pressure. Easier and Easiest give progressively greater effect at lower pressures. Dual switch provides a map with a large "gap" between effects at low and high pressures. This can be very effective when pressure is used as a Control source—for example, if MPress is used as the Layer

Enable control for Layer 2 of a two-layer Program, then setting the RPrsMap to Dual switch will give you a convenient on/off switch for Layer 2, triggered by the amount of aftertouch you apply to your controller.

008 Edit Receive Pressure Map
(Edit RPrs Map? in display)

When you answer YES here, you will enter a Submenu containing Parameters 1500 - 1508. See Section 6.4.

009 Program List
(PList in display)

- **Browser I**
- **Browser II**
- **Library I**
- **Library II**
- **RAM Library**

Program Lists (often called "maps," because they map one Program number to another) are a feature you'll use only if your K1200 is connected to another MIDI device. If the K1200 is the Master MIDI device, the Program Lists will affect the way the Slave device responds to Program Change messages sent from the K1200. If your K1200 is the Slave device, the Program Lists will determine how the K1200 responds to MIDI Program

Change messages sent to the K1200 from the Master device.

Program Lists give you the flexibility to work around a significant limitation of the MIDI specification. The limitation is this: when using MIDI commands to change Programs, you can send Program Change Values of 0 to 127 (or 1 to 128)—and no higher. If your system includes MIDI devices which use Program numbers outside this range, you'll need to use Program Lists to select those Programs using MIDI. In the sidebar beginning on page 50, you'll find a general overview of the K1200's Program mapping architecture. Also discussed are the basics of Program List editing.

010 Edit PList?

When you answer YES to this Function Parameter, you'll enter the Program List Editing Submenu, containing Parameters 1700 - 1705. See Section 6.6.

011 Bin Map

- **Bins**
- **QuickMaps**

You can create specific sets of Programs and store them in memory. These sets of ten

Program numbers, called Bins, can be stored in any of three Banks, labeled A, B, and C. These Bin Banks can store 30 different Programs, allowing you to select them with a single press of the numeric buttons.

If you want to store more than 30 Program numbers, you can save the settings for your original Bin Banks in a Bin Map, and create additional Bin Maps, each containing a different set of 30 Program numbers.

Master Parameter 011 is used to select a Bin Map, both for performance and for editing. In PLAY mode, when you select a Program using the Bin Banks, the Program will be selected according to the numbers assigned to the current Bin Map. You also can select Bin Maps from the front panel in PLAY Mode. See Section 3.4.

The Map called Bins contains a selection of K1200 Programs. The Map called QuickMaps contains Velocity Maps in Bank A, Pressure Maps in Bank B, and Intonation Tables in Bank C.

012 Edit Bin Map

Answer YES here, and you will enter Submenu 1800, Bin Btn Map. See Section 6.7.

Section VI

Program Lists in the K1200

The K1200 is a computer, rapidly processing blocks of information in response to the control messages you send. The K1200 stores and processes many specialized blocks of information which we call "Objects." The K1200 recognizes an Object by looking at its Type (Program, Bin Map, Intonation Table, etc.) and ID number (which Object of any particular type, since there are many of each type).

Programs are just one of the K1200's many types of Objects, all of which follow the same rules: every Object has a Type (PROG, in this case), and a unique ID number to distinguish it from other Objects of the same type.

When you select a K1200 Program, the K1200 finds it by looking for all Objects of type PROG, then searching through the Program Lists to find the ID number that corresponds to the Program number you selected. What is important to understand is that the ID number of the Program is **not necessarily** the same as the Program number you see in the K1200's display. This is because the K1200's Program List feature allows you to map any Program ID number to any display Program number. Often they will be different. Although this may seem difficult to understand at first, there are several advantages to this approach.

One major advantage concerns the MIDI limitation we mentioned earlier: MIDI allows the transmission of Program numbers from 0 to 127 (or 1 to 128) **only**. This means, for example, that a K1200 Program (a PROG Object, to be precise) with ID number 255 cannot be selected directly from a MIDI controller. By editing a Program List, however, and mapping the PROG Object with ID 255 to a Program number from 0 to 127 (36, for example), you can select the Program from your MIDI controller by sending a Program Change number of 36. The K1200 will receive the message, look to the appropriate Program List to see which PROG ID number is assigned to Program number 036, and will select that PROG Object, displaying its Program number. As far as the MIDI controller is concerned, you have just selected Program 036.

Figure 6-1 will help you visualize the relationship between PROG Objects (the information the K1200 uses to generate its sounds) and the Program number (as seen in the K1200's display) to which the PROG Object is assigned. There also is a detailed description of Program List editing in Section 6.6.

Another sizable advantage of the K1200's Program List structure is that it offers an easily accessible library of 1000 Program numbers—ten Program Lists, each of which has 100 entries. Keep in mind that this does not mean that the K1200 has a thousand Programs—it simply means that there are a thousand different Program numbers to which you can assign any of the PROG Objects currently stored in the K1200's ROM and RAM.

You might think of the Lists as being numbered like this: List 1, List 2, List 3, etc. You won't actually see the Lists numbered in the display—you'll see only the names of the Lists. Nevertheless, the Lists are easy to

PROG Object ID #	Program Number
159	000
2	001
13	002
35	003
43	004
70	005
.....
.....
.....
.....
.....
.....
.....
.....
82	094
71	095
26	096
100	097
150	098
139	099

Figure 6 - 1. Program ID#s map to Program numbers

Program Lists in the K1200 (continued)

identify by their first digit. Program numbers 000 to 099 are contained in List 1 (Called "Browser I," unless you've changed it). Program numbers 100 - 199 are contained in List 2 (Browser II), and so on. Remember that these numbers are the numbers of the Programs as they appear in the K1200's display—don't confuse them with the actual PROG Object ID numbers. The Program Lists take care of relating the PROG ID numbers to the Program numbers.

Remember that you won't need to do any Program List editing unless you're connecting your K1200 with other MIDI devices. If you're using the K1200 as a solo instrument, Program changes are extremely simple. You can select any Program number from 000 to 999 using the ENTER and numeric buttons. As long as a PROG Object is assigned to that Program number, it will be selected instantly. If the selected Program is not in the same Program List as the current Program, the K1200 instantly switches to the appropriate List.

To select Program 925, for example (assuming you had already stored a PROG Object at Program number 925), you would simply press ENTER, 9, 2, 5, ENTER. Unlike many other instruments, you do not have to select the List first, selecting the Program afterward. You actually select the List and Program in one function. Pressing the 9 selects List 10 (Program numbers 900 - 999), then the 2 and 5 select Program number 25 within that List. All you need to remember is that the lead sound for your opening tune is Program number 925.

If you select a Program number which doesn't have a Program (PROG Object) assigned to it, the K1200 will tell you that that Program number was not found. You then will return to the previously selected Program.

If you're wondering how you're going to select Program number 925 from your MIDI controller, or insert Program Change number 925 in a sequencer track, you'll find the answer in the sidebar entitled "Extended Program Changes," on page 52.

013 Intonation Table

- Equal
Classic Just
Just w/b 7th
Harmonic
Just Harmonic
Werkmeister
1/5th Comma
1/4th Comma
Indian Raga
Arabic
Bali/Java1
Bali/Java2
Bali/Java3
Tibetan
CarlosAlpha
Pyth w/aug4
Pyth w/dim5

Selects from a list of temperament tables which define the intervals between notes within the octave.

Intonation tables are listed by name. The default Value is Equal temperament, which is the temperament used on a standard piano.

All of the Intonation Tables preserve octave relationships (all Cs, for example, are spaced one octave apart), but each Table has different tunings for the intervals between semitones. In the "Equal" Table, for example, the interval between each semitone is 100 cts.

Section VI

Extended Program Changes

The K1200 allows its Programs to be numbered from 000 to 999, yet all 1000 Program numbers are accessible from any standard MIDI controller, by sending Program Change numbers from 0 to 127 (or 1 to 128). The K1200's Extended Program Change feature makes it possible. Actually, the K1200 responds normally only to Program Change numbers from 0 to 99. Above 99, the K1200 either ignores the hundreds digit (if Parameters 003 and/or 004 are set to On), or it interprets them as signals to select PLists (if Parameters 003 and/or 004 are set to Ext).

Any of the K1200's Program numbers can be selected with no more than two Program Change messages from an external MIDI controller. Here's how it works. Any time the K1200 receives a Program change number of 0 to 99, it responds by selecting the Program (PROG Object) stored at that Program number in the currently selected Program List. For example, if List 3 (Program numbers 200 - 299) is the currently selected PList, and you send the K1200 a Program Change number of 64, the K1200 will select Program number 264 (you'll see the number "264" in the display).

When Parameter 003 is set to Ext, the K1200 sends an extra Program Change message when you select Program numbers above 99. The first Program Change number specifies the hundreds digit, and the second specifies the tens and ones. For example, if you selected Program number 925 from the front panel, the K1200 would send Program Change number 109, then 25.

To select different PLists from an external MIDI controller, send Program Change numbers of 100 - 109. Program Change number 100 selects PList 1 (Programs 0 - 99). Program Change number 101 selects PList 2 (Programs 100 - 199) 103 selects PList 3, and so on. If, for example, the currently selected Program is Program number 264, and you want to select Program number 009, send the following Program Change numbers: 100 (selects PList 1) and 9 (selects Program number 9 in the current PList). It doesn't matter which of these Program Change messages you send first, although if you are inserting these Program Change numbers in a sequence track, make certain that they don't occur too close together, because some sequencers will not send two Program Change messages on the same tick. Set the Program Change messages to different ticks, or beat fractions, or whatever units your sequencer uses.

014 Edit Intonation Table

• Yes

Enables you to edit the current Intonation Table (the one selected with Parameter 013).

The Intonation Table Editor allows you to specify the size of each of the twelve chromatic intervals in an octave, relative to the tonic (reference key). You select the Values for one octave, then the K1200 extrapolates those intervals to the remaining octaves in its range.

Pressing YES in response to this Parameter takes you to the Edit Intonation Table Submenu, Parameters 1400 to 1414 (see Section 6.3). Be sure you have used Parameter 013 to select the Intonation Table that you want to edit before you start making changes.

015 Intonation Reference Key

• C, C# . . . B

Establishes a reference key (by specifying the tonic note of that key) for whichever Intonation Table is selected using Parameter 013. The default Value is C.

The reference key determines which key you should play in to make the Intonation Table sound "correct." It is important because the K1200 cannot guess which key you'll be

playing in. Consider this example: You have chosen an Intonation Table which adjusts the minor 2nd (the interval between *do* and *di*) +100 ct, and have selected a Reference Key of C: This means that when you play any C# on the keyboard, you will actually hear a D from the K1200. If you play a piece of music suited to this intonation, it will sound fine *as long as you play in the key of C*.

If you modulate to the key of F, however, the piece will not sound the same, because the K1200 still “thinks” that C is *do*. If you change the Reference Key to F, then the interval between F and F# will be adjusted appropriately.

016 MIDI Reference Key

- Off
- On

Allows you to use MIDI data to select a reference key, as an alternative to using Parameter 015.

In a performance situation, you might not have time to change reference keys using Parameter 015. You can use Parameter 016 to rapidly change your reference key as frequently as you wish.

With a Value of Off (the default), incoming MIDI data have no effect on the selection of a reference key.

Select a Value of On, and you can change the reference key by sending a MIDI Note On signal for MIDI Note numbers 0 to 11 (C-1 to B-1). A Note On signal at C-1 sets the reference key to C; a Note On signal at C#-1 sets the reference key to C#, and so on. A standard 88-key MIDI controller has keys beginning at MIDI Note number 21 (A0), so you probably will need to transpose down on your MIDI controller to use this feature.

Note — As long as the Value for Parameter 016 is set On, a Note On signal in the range from C-1 to B-1 will not produce a sound on the K1200, but will only change the reference key.

017 Basic MIDI Channel

- 1-16

Selects the basic MIDI channel for the K1200. The Basic Channel cannot be disabled, and disabled channels cannot be selected as the Basic Channel.

In Omni On Mode (Omni in the display), all channels will receive channel messages, including MIDI mode change messages. All other Channel messages will be received by all 16 channels. In Omni Off Mode (Poly in the display), the Basic Channel is the only channel that can receive Channel messages of any kind.

018 Tune

- ±100 ct
- +10 ct

Tunes the entire instrument up or down as much as one semitone, in steps of one cent (1/100th of a semitone). A Value of 0 tunes the K1200 to A4 = 440 Hz. A Value of -32 tunes it to A4 = 432, and a Value of -38 tunes to C4 = 256.

Master Tune is used to match the pitch of the K1200 to that of another instrument or to a non-standard tuning.

019 Transpose

- ±60 ST
- +12 ST

Transposes the pitch of the K1200 as much as five octaves (±60 ST) up or down, in steps of one semitone (ST). One octave contains 12 ST.

Master Transposition lets you play in one key on your K1200 and hear your music in another key. It also affects incoming MIDI data, but not the data transmitted from the K1200's MIDI Out port.

020 Mono Output

- On
- Off

Toggles between Mono and Stereo for the audio output.

Section VI

A Value of On sums the left and right channel signals so that the entire audio signal is present at both outputs, overriding all Layer and Channel Pan settings and creating the effect of Mono output for all Layers of all Programs. (Note that this does not *alter* the Pan settings; it simply ignores them.) Use this setting if you do not have a stereo sound system, or if your amplifier has only one input.

A Value of Off allows individual Layers to be panned in stereo. Signal levels at the left and right outputs will be determined by the Value assigned to Layer Menu Parameter 230 (Section VIII) or the Channel Editing Parameters (Section 6.1).

021 Pitch Bend Range

- Prog
±6 QT

Enables you to set a uniform range for Pitch Bend for the entire K1200, overriding the Bend Range settings of each Layer.

A Value of "Prog" (the default) will deactivate this Parameter, causing all Pitch Bend Ranges to be defined according to the Values set in each Layer for Parameter 224 in the Layer Menu.

Values of -6 to +6 QT (Quarter-tones) will cause the Bend Range of all Layers to be set

correspondingly. Values above 0 will cause the Pitch to bend upward when the Pitch Wheel is pushed upward, while Values below 0 will cause the Pitch to bend downward when the Pitch Wheel is pushed upward.

022 Ignore All Notes Off

- Off
On

Enables the K1200 to respond to or ignore All Notes Off messages from your MIDI controller. This Parameter affects all MIDI channels. The default Value is Off, which means that the K1200 will respond to All Notes Off messages.

Select a Value of On to ignore All Notes Off messages sent by your MIDI controller. This is an important feature, since some MIDI controllers send occasional All Notes Off messages even if you don't want them to.

Roland products, for example, send an All Notes Off signal whenever their MIDI data stream stops. If you are using a Roland product with your K1200, it may not sustain properly unless you set Parameter 022 to On. (As an alternative, you can leave this Parameter set to Off, and set Parameter 023 to Soft).

Select a Value of Off if you want the K1200 to respond to All Notes Off messages. This will

enable you to use any "Panic" or "All Notes Off" features that your MIDI controller may have: with a Value of Off, the K1200 will cancel notes according to the setting you have chosen for Master Parameter 023.

023 All Notes Off

- Hard
Soft

Some synthesizers and MIDI controllers send periodic All Notes Off messages, which can cause unwanted interruption in your music. The K1200 enables you to choose between two options which affect the way the K1200 responds to All Notes Off messages.

With a Value of Hard (the default), the K1200 will respond to an All Notes Off message by terminating all currently sounding notes without exception. A Value of Soft enables the K1200 to preserve all notes held by the sustain function. All others will be terminated.

Use either [VALUE] button to toggle between the Values for this Parameter. This Parameter is in effect only when Master Parameter 022 is set to Off. If Parameter 022 is set to On, All Notes Off messages will be ignored.

024 Global Dynamic Range Adjust
(Dynam Adj in display)

- 0 dB
± 48 dB

With this Parameter you may adjust the dynamic response of the entire K1200, much as you control the response of each individual Layer with Layer Parameter 218. Increasing the Value will increase the range between the least and greatest loudness achieved by any note when you vary the note-on velocity (or any amplitude control). Use either [VALUE] button to change the Value in 1 dB increments. Press and hold to scroll rapidly. Press both [VALUE] buttons at the same time to increase in steps of 6 dB, and to wrap from +48 dB to -48 dB. If your sound system is low on headroom, you might set this Parameter to a negative Value.

025 Pressure

- Both
Mono
Poly

Many of the effects in the K1200's preset Programs are controlled by pressure (aftertouch). The K1200 allows you to select both monophonic (channel) and polyphonic (key) pressure as control sources. You'll use this Parameter to

define how the K1200 responds to aftertouch signals both from its own keyboard, and from external devices.

The K1200's keyboard sends only mono (channel) pressure, therefore its Programs are designed to respond to mono pressure. This Parameter's default setting of Both will enable you to hear all of the K1200's mono pressure effects when playing it from its own keyboard. It also allows K1200 effects triggered by poly pressure to be controlled from an external MIDI device which sends poly pressure.

If you set this Parameter to Mono, the K1200 will interpret all pressure signals as mono pressure signals. Even if you used a MIDI controller to send poly pressure messages, the K1200 would respond to them as mono pressure messages.

Choose Poly to convert most mono pressure effects to poly pressure effects. You would want to do this only if you were controlling the K1200 from a MIDI controller which is capable of sending poly pressure (such as the Kurzweil MIDIBOARD). With Pressure set to Poly, most K1200 effects which are programmed to respond to mono pressure only will respond instead to poly pressure. Effects which are not affected by this conversion are global LFOs and ASRs.

If you assign poly pressure as the Control Source for an effect, then you will not hear the effect when played from the K1200's keyboard unless you have this Parameter set to Mono. The effects would then be heard, but you would not have note-by-note control over the effect.

026 Master Channel Stealing Algorithm
(Stealer in display)

- Prog (Program)
Poly 1
Poly 2
Mono

This Parameter is almost identical to its counterpart in the Program Menu. It allows you to select a channel stealing routine for the entire K1200, which overrides the Program-level Stealer setting for each individual Program. This is a quick way, for example, to make the entire K1200 a monophonic sound source for use with monophonic MIDI controllers.

The default Value of Prog simply defers control of the Stealer routine to the individual Programs.

At Poly 1, when you retrigger a note (or group of notes) before the original note(s) has died out, the K1200 will reuse the same channel (or group of channels) for the second note(s), silencing the first note(s).

Section VI

At Poly 2, the K1200 steals channels on the third triggering of the same note(s), instead of the second.

At Mono, as you would expect, only one audio channel is available at any time, making the entire K1200 monophonic.

027 MIDI System Exclusive ID

- 0 to 126
- +16

Provides a MIDI code to identify the K1200 uniquely among various connected MIDI devices.

System Exclusive messages require a device identification code (in addition to the Manufacturer's code — Kurzweil's Manufacturer's Code is 07) in order to be able to address the correct MIDI device. This Parameter allows you to set the K1200's Sys Ex Device ID to any Value from 0 to 126. The K1200 will receive Sys Ex messages — regardless of MIDI Mode, Basic Channel, or currently selected Channel — when its Sys Ex ID is properly addressed. The default Value for this Parameter is 0.

028 MIDI Editing

- On
- Off

Allows you to enable or disable MIDI editing capability.

Selecting a Value of On instructs the K1200 to respond to certain incoming MIDI data as remote editing commands. Data received from the Non-registered Parameter Controls (e.g. MIDI 27), the Data Entry Control, and the Increment/Decrement MIDI buttons on remote MIDI devices will be interpreted as editing commands, and will change the Value of the currently selected Parameter, when in EDIT Mode.

With Parameter 028 set to Off (the default Value), data from these controls will be ignored.

029 Confirmation

- On
- Off

Allows you to prevent the "Are you sure?" warnings that appear when you are at risk of losing, or significantly changing, data in the K1200's memory.

Once you have become an experienced K1200 programmer, you may find some of the warnings about losing data unnecessary. This Parameter enables you to dispense with all but the most crucial warnings (one warning related to resetting the K1200 will always remain). Simply select a Value of Off, and most of the "Are you sure?" warnings will disappear.

030 Show Software Version

- Yes

Allows you to view the version of the K1200's operating software. The display's upper line briefly shows the Engine software version, and the lower line shows the Setup software version.

Pressing NO at this Parameter will move you to the next Parameter.

031 MIDI Chain Link

- 1/1 to 12/12

Enables you to separately identify each of up to twelve 1200s linked in parallel via MIDI. Chain Link positions are displayed as two numbers divided by a slash mark. The first number represents the unit's position in the chain, and the second number represents the total number of units in the chain.

For example, if you had six 1200s chained together, the first unit in the chain should have Parameter 031 set to a Value of 1/6, and the last unit in the chain should have this Parameter set to a Value of 6/6. Each 1200 would be responsible for two notes in each octave of the MIDI keyboard.

This procedure allows you to play up to twelve 1200s simultaneously from one MIDI controller without MIDI delays. It also allows you to effectively create a 288-note polyphonic unit consisting of twelve 1200s!

MIDI DUMP COMMANDS

The K1200 offers three Master Menu MIDI dump commands which allow you to dump programming information from the K1200 into a computer or sequencer, then load it back into the K1200. The dump commands also may be used to transfer information from one 1200 to another. Each of these dumps is initiated by pressing [YES] when the desired dump function's Parameter is visible in the K1200's display. These dumps also may be initiated by a system exclusive message from an external source.

032 Dump Programs? (Dump Progs? in display)

Initiates a MIDI dump of all RAM Program information. Note that this dump includes only the Program-related Parameters, Values and Tables—not the actual Soundfiles themselves. You would not be able to use this Function Parameter, for example, to load the guitar samples from your Kurzweil GX into your K1200. You could,

however, load the (RAM) Program information from your GX into your K1200, then use that Program information to affect the K1200's Soundfiles according to the Program specifications of the GX.

033 Dump Master?

Causes the K1200 to dump its Master Parameter Table. This is effective for creating files of Performance Setups, as a backup or as a means for quickly reconfiguring your K1200.

034 Dump Memory?

Initiates a dump of all User and RAM objects. Answer [YES] to the prompt to initiate the dump. You may want to do this before you begin programming your K1200. This will give you a backup of the factory settings and songs.

MIDI Dump For Programs and Other Objects—You may dump Program information for individual Programs, using the Program Menu Function Parameter **107 Dump Prog?** Select Function Parameter 107 from the Program Menu, answer [YES], and the Program definition for the currently selected Program will be transmitted as a SysEx message.

There are also Master Menu Function Parameters for dumping several other Objects on an

individual basis. These Function Parameters are located in the corresponding Master Submenus:

1213 Dump Vel Map? (answer [YES] to Parameter 006 or 040),
1705 Dump ProgList?
(Parameter 010 Edit PList?),
1415 Dump Int Tab?
(Parameter 014 Edit ITbl?),
1512 Dump Prs Map?
(Parameter 038 Edit Prs Map?),
1805 Dump Bin Map?
(Parameter 012 Edit Bin Map?),
2004 Dump PSetup?
(Parameter 044 Edit PSetup?).

035 Delete Song?

- Yes

This Parameter enables you to delete individual songs (Demo sequences), to free up memory. Answer YES to this Parameter to begin the standard deletion sequence as described in Section 4.4.3.

036 Delete RAM Programs (Delete All Prgs? in display)

- Yes

Deletes all user-defined (RAM-based) Programs from the K1200. Use this Parameter to clear the Program memory of your K1200 without affecting the Master settings.

When you answer Yes to this Parameter, the K1200 will give you two warnings (or one, if the Value of Parameter 029 is Off)

Section VI

before deleting your Programs. RAM Programs which are assigned to active MIDI channels will not be deleted.

037 Reset 1000

- **Yes**

Answering YES to this Parameter will delete all RAM-based Programs and Demo songs, and all Master Menu Values, including MIDI Program Maps, Intonation Tables, and settings for Tuning and Transposition. It restores every one of the K1200's Parameters to its default Value.

You probably will not want to reset your K1200 unless it seems hopelessly hung up, or if you are absolutely certain that you don't want to save any of your settings. If you really want to reset your K1200, however, press YES. You'll have as many as two additional opportunities to change your mind.

After your third response of YES, the display will disappear briefly, then reappear as it does when you power up. Only the factory settings will remain.

Keep in mind that at any time during the above sequence of responses, you may exit by pressing NO.

038 Edit Transmit Pressure Map (Edit XPrs Map? in display)

When you answer YES, you will enter a Submenu containing Parameters 1500 - 1512, where you can edit the Pressure Map you selected with Parameter 039. See Section 6.4. Keep in mind that if you change a Pressure Map, then select it as a Receive Pressure Map, the changes you made will affect that Map even though you edited it as a Transmit Pressure Map. This is because there is only one type of Pressure Map Object; any Pressure Map can be selected as either the Receive Map or the Transmit Map (or both).

039 Transmit Pressure Map (XPrs Map in display)

- **Linear**
- **Low Bias**
- **Easier**
- **Easiest**
- **Dual Switch**

The Transmit Pressure Map works in much the same way as the Receive Pressure Map (Parameter 007), with the exception that it controls the values of the mono pressure information sent from the K1200's MIDI Out port. Please see the discussion of Parameter 007 for a description of the characteristics of the different Pressure Maps.

The Transmit Pressure Map is actually the inverse of the Receive Pressure Map. Experiment with different Values to

find the one which works best with your controller.

040 Edit Transmit Velocity Map

- **Yes**

Pressing YES at this Parameter will take you to the Velocity Map Submenu (See Section 6.2). You then will be able to edit the Velocity Map that you have selected with Parameter 005 or 041 (be sure to select the Velocity Map to edit before selecting Parameter 040).

041 Transmit Velocity Map (XVelMap in display)

- **Hardest**
- **Harder**
- **Hard**
- **Medium**
- **Easy**
- **Easier**
- **Easiest**
- **DX7 Hard**
- **DX7 Medium**
- **DX7 Easy**
- **Linear**

Velocity Maps determine the relationship between the key-strike velocity and the dynamics (loudness) and brightness of the sound produced by the K1200. Different Velocity Maps allow you to customize the dynamic response of the K1200 to different MIDI controllers and playing styles.

The preprogrammed Velocity Maps listed above are supplied in ROM. They are defined to

work effectively with various MIDI controllers, as reflected in the names of some of the Maps.

Velocity Maps also may be edited, renamed and saved in non-volatile RAM, to be selected and used with different MIDI controllers or playing styles. See Parameters 040 and 1200 through 1213 (Section 6.2) for more information.

The Transmit VelMap actually works in the reverse of the Receive VelMap. In other words, it requires greater velocity at the hardest settings to achieve full dynamics in the K1200. As a rule, it should work well with most MIDI controllers. Try all of the maps, and let your ears be your guide.

042 Local Control

- On
- Off

This is a global keyboard control Parameter. If you set this Parameter to Off, the K1200 will not receive its own keyboard and control information, regardless of the currently selected PSetup's settings. Set this Parameter to Off if you want the K1200 to be a MIDI controller only, or if you are using a sequencer which is looped to the K1200 (MIDI Out of one to MIDI In of the other, and vice versa), and the sequencer has its Play thru feature on. Otherwise, you'll probably leave this Parameter set to On.

043 Edit Default Control Sources

Answer NO if you do not want to view or edit the control assignments contained in the Submenu under this Parameter. If you answer YES, you will enter a Submenu, enabling you to change the default assignments for the K1200's basic performance configuration. This Submenu contains Parameters 1601-1606, and is discussed later in this section.

044 Edit PSetup?

When you answer YES to this Parameter, you'll enter the PSetup Editing Submenu, which contains Parameters 2000 - 2021. See Section 6.8 for a description of Performance Setup editing Parameters.

045 Performance Setup (PSet in display)

- Current (User-defined PSetups)

This Parameter provides one of two ways to select Performance Setups (the other method works from PLAY Mode, using the Bin Banks). When this Parameter is shown in the display, simply use the VALUE buttons to scroll through the list of available PSetups. Note that until you create and save PSetups of your own, the only Value that will

appear is "(current)." See the discussion of Performance Setups in Section 6.8 if you're not familiar with the functions of Performance Setups.

6.1 Channel Editing Submenu

When you Press YES in response to Parameter 001, you'll enter the Channel Editing Submenu.

The Channel Editing Submenu is divided into 16 sections, each of which has an identical list of Parameters which allow you to set performance specifications for each MIDI channel. Use either PARAMETER button to scroll through the list of Parameters for the currently selected MIDI channel. Use either MENU button to select the Menu for another Channel.

Keep in mind that these Parameters are relevant only when your K1200 is set up to receive MIDI data from an external MIDI controller or sequencer.

1010 Channel 1

This is the Menu heading for the first Menu in the Channel editing Submenu.

1011 Volume Control

- Off
- On

Section VI

Enables/disables MIDI control over Volume for all Programs assigned to MIDI Channel 1.

A Value of On (the default) enables MIDI Volume control, assuming that you have a function on your MIDI controller that is assigned to control Volume (MIDI Control Number 7). A Value of Off causes the K1200 to ignore any MIDI Volume messages received on MIDI channel 1.

1012 Volume

- ± 48 dB
- +6 dB

Sets the volume (loudness) for all Programs assigned to MIDI Channel 1. When the Value of Parameter 1011 is set to On, the maximum volume of Programs assigned to Channel 1 will be set by the Value of this Parameter.

Keep in mind that this volume level is relative to the other channels. If maximum volume is reached, the other channels will be reduced in volume. It is therefore better to adjust the Volume Parameter down, rather than up.

1013 Pan Override

- Off
- On

Enables you to determine Pan settings for all Programs assigned to MIDI Channel 1,

overriding the Pan assignments in every Layer of those Programs. The default Value is Off.

A Value of On causes all Programs assigned to Channel 1 to use the Pan setting defined with Parameter 1014 (Pan).

A Value of Off leaves Pan settings as assigned for each Layer, according to the Values set for Layer Menu Parameter 230 (Stereo Pan).

1014 Pan

- L to R
- Auto
- Inv Auto

Enables you to define Channel Pan settings between the Left and Right Audio Outputs.

Use either VALUE button to change the Pan location. The display will show an asterisk (*) which indicates the position of the current Layer with respect to the Audio Outputs.

There are eleven normal positions, including the extremes (when the asterisk is immediately adjacent to the L or R). A position in between will place the output of MIDI Channel 1 Programs at different levels at each Audio Output, with the center position providing an equal balance between Audio Outputs.

If you select a Value which exceeds either extreme, the

display will change to show two additional Values—Auto Pan and Inv Auto Pan. These provide Pan settings which are a function of MIDI Note number.

Select Auto Pan, and the lowest notes of the Program on MIDI Channel 1 will be directed to the Left Audio Output of the K1200. The highest notes will be directed to the Right Audio Output, with a progressive pan from left to right with each successively higher note.

Select Inv Auto Pan, and the Channel Pan function will be the reverse of the above (low notes to the right, and high to the left).

1015 MIDI Range

- Off
- On

Activates/deactivates Channel-based assignment of Low Note and High Note settings. The default Value is Off.

With the Value set to On, all Programs assigned to MIDI Channel 1 will be limited to the keyboard range (region) defined by Parameters 1017 and 1018 of this Menu (or via MIDI, using Parameter 1016).

With the Value set to Off, keyboard ranges will be determined for each Layer according to the Values for Layer Menu Parameters 210 and 211 (or via MIDI using Parameter 209).

1016 Set MIDI Range

- Yes

Allows you to use your MIDI controller to set the range that will be assigned to any Program on MIDI Channel 1 if the Value of Parameter 1015 is set to On.

When you answer Yes to this Parameter, the display will prompt you to strike a key on your MIDI controller. When you do, the display will ask you to strike another key, and then will return to the "Set MIDI Range?" display. This sets a keyboard range between (and including) the two keys that you struck.

Press NO at any time to abort and return to the "Set MIDI Range?" display.

1017 Low Note

- C0 to C8
- + 1 octave (12 ST)

Allows you to set or change the lowest key that can be used by Programs on MIDI channel 1.

The Value displayed is an alphanumeric character representing the keys of a MIDI controller. The letter (A, B, C, etc.) refers to the notes of the chromatic scale. Black keys (e.g. C-sharp) are represented by a letter and the symbol "#." The numeral indicates the octave number.

Some examples: Middle C is represented as C4. The F-sharp above Middle C is represented as F#4. The highest C on a standard piano is C8. The lowest C on a standard piano is C1, and the octave number increases at each C. All keys below C1 are considered to be in Octave 0; the lowest A on a standard piano, for example, is A0.

Notice that you may set a range that goes below the normal range of a standard piano keyboard. The range may also exceed the normal range of a particular Soundfile. Nothing will be heard if you strike a controller key outside the range of the Soundfile.

1018 High Note

- C0 to C8
- + 1 octave (12 ST)

Allows you to set or change the highest key that can be used by Programs on MIDI channel 1. Parameter 1018 operates in exactly the same fashion as Parameter 1017.

Notice that the Values you set for each of these Parameters determine how the display wraps when you execute a dual press of the VALUE buttons. The available Values for Low Note will not exceed the Value set for High Note, and will wrap to C0 before reaching this limit. The available Values for High

Note will not go below the Value set for Low Note, and will wrap to the Low Note Value from the highest octave above the Low Note Value.

1019 Polyphonic Limit

- Off
- 1-24
- 8
- 16
- 24
- Off

Enables you to set the Polyphonic Limit of Programs on MIDI channel 1, independent of the Programs on other MIDI channels.

With the Value set to Off (the default), polyphonic limits for each Program are determined according to the Values set for Program Menu Parameter 106 (Poly Limit).

At any Value from 1 to 24, all Programs assigned to MIDI Channel 1 will be limited to the number of simultaneous notes indicated by the Value you set.

Section VI

6.2 Velocity Map Submenu

1020 – 1029	Editing Menu for MIDI Channel 2
1030 – 1039	Editing Menu for MIDI Channel 3
1040 – 1049	Editing Menu for MIDI Channel 4
1050 – 1059	Editing Menu for MIDI Channel 5
1060 – 1069	Editing Menu for MIDI Channel 6
1070 – 1079	Editing Menu for MIDI Channel 7
1080 – 1089	Editing Menu for MIDI Channel 8
1090 – 1099	Editing Menu for MIDI Channel 9
1100 – 1109	Editing Menu for MIDI Channel 10
1110 – 1119	Editing Menu for MIDI Channel 11
1120 – 1129	Editing Menu for MIDI Channel 12
1130 – 1139	Editing Menu for MIDI Channel 13
1140 – 1149	Editing Menu for MIDI Channel 14
1150 – 1159	Editing Menu for MIDI Channel 15
1160 – 1169	Editing Menu for MIDI Channel 16

Each of the above Menus operates in the same fashion as the Menu for MIDI Channel 1.

EXITING THE MIDI CHANNEL SUBMENU

Press PLAY to return to the Master Menu.

Parameters 1200 through 1212 are accessed by answering YES to Master Parameter 006 or 040. Note that there is only one type of Velocity Map Object, which can be selected either as the Transmit Map or the Receive Map.

1200 Velocity Map

This is the heading for the Velocity Map Submenu.

1201 Set MIDI Velocity Map • Yes

Enables you to set the softest (ppp) and the hardest (fff) keystrike Velocity number for the current Velocity Map, using the K1200's keys.

The K1200 will interpolate the Values for the remaining six Velocity numbers in the Map, creating a linear Map from the minimum and maximum Velocity numbers you set with your keystrikes.

Press Yes to activate the MIDI Velocity Map sequence. The display will prompt:

Strike key ppp!

If you change your mind at this point, press NO to exit to the "Set MIDI VMap?" display, then press a PARAMETER button to select another Parameter. Otherwise, strike a key, using the force you wish to set as the

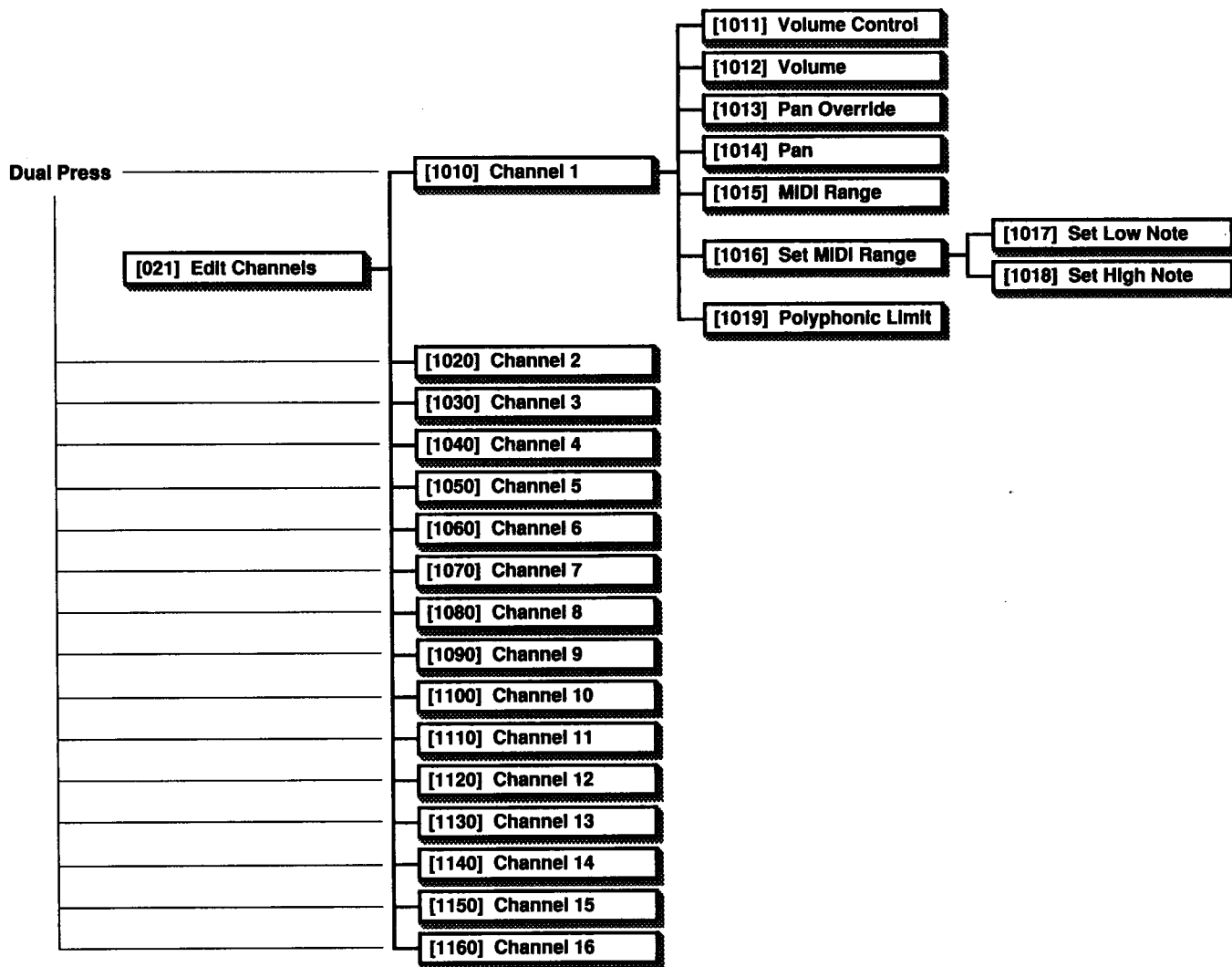

lowest MIDI Velocity number for this Velocity Map. The display then will prompt:

Strike key fff!

Again, you may abort with the NO button. Otherwise, striking another key will set the *highest* MIDI Velocity number for the current Map. When the K1200 has finished calculating the remaining six values, the display will return to Parameter 1201.

You may now use the PARAMETER buttons to view the eight dynamic levels and the Values assigned by the K1200, and edit them if you choose. You'll notice that whichever keystrike is lighter will be assigned as the "ppp dynamics" keystrike; it doesn't matter if you struck it first or second.

If you wish to create unusual Velocity Maps, or non-linear ones, you can use Parameters 1202 through 1209 to set Velocity Map Values manually.

- 1202 ppp
- 1203 pp
- 1204 p
- 1205 mp
- 1206 mf
- 1207 f
- 1208 ff
- 1209 fff

- 0 to 127 vel
- +10 vel

Parameters 1202 through 1209 enable you to edit the current Velocity Map. Editing of Velocity Maps is performed by setting

Section VI

MIDI velocity numbers (abbreviated "vel") for eight relative dynamic levels corresponding to the force with which you strike the keys (or the equivalent on your MIDI controller). These dynamic levels are labeled using standard musical terminology (ppp to *fff*).

The K1200 will calculate the MIDI velocity numbers for every keystroke hardness level in between these Values.

Velocity Maps affect both the K1200's internal response to velocity values, and its MIDI Out velocity values as well.

1210 Name Velocity Map

- Yes

Enables you to name the current Velocity Map.

A YES answer activates the naming sequence. If you need a review of the naming procedure, see Section 4.4.1 of the *Performance Guide*.

1211 Save Velocity Map

- Yes

This Function Parameter saves (stores) the currently selected VelMap in RAM.

Press YES to initiate the saving sequence. If you need a review of the saving procedure, see Section 4.4.2 of the *Performance Guide*.

1212 Delete Velocity Map

- Yes

Enables you to delete (erase) the current Velocity Map.

Pressing YES will begin the deletion sequence as described in 4.4.3 of the *Performance Guide*.

1213 Dump Velocity Map

- Yes

Press Yes to initiate a SysEx dump of the current Velocity Map.

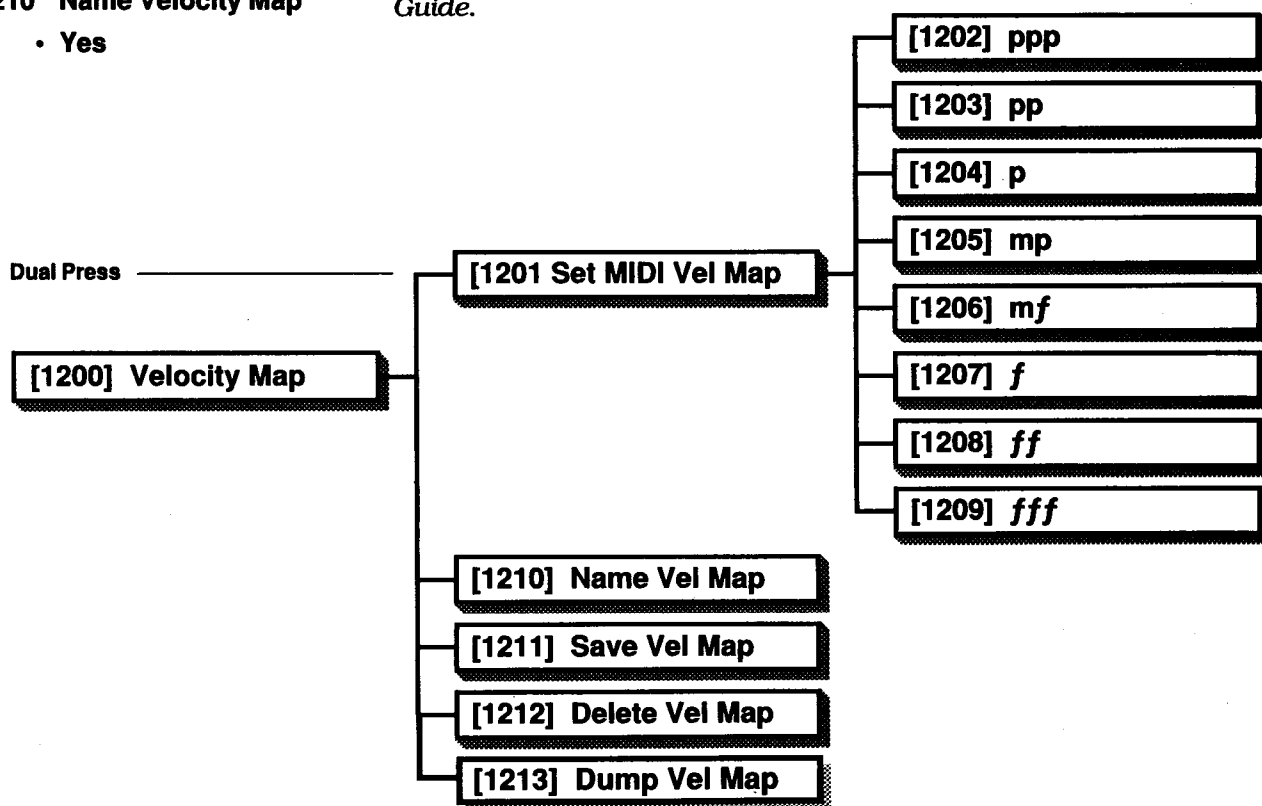

EXITING THE VELOCITY MAP SUBMENU

Press **PLAY** to return to the Master Menu. If you've made any changes to the Velocity Map, you will be asked whether you want to save the Velocity Map before returning to the main Master Menu.

Values for each of these Parameters is set at 0, an equal temperament is achieved.

You can use Parameter 014 (Edit Intonation Table) to study any of the preset Intonation Tables by following these steps:

1) Select the Intonation Table to be examined (Parameter 013);

2) Call up the Intonation Table Editor Submenu using Parameter 014;

3) Study the Values for Parameters 1401 through 1411.

6.3 Intonation Table Editor Submenu

Parameters 1401 through 1411 let you create your own musical scale by modifying the chromatic intervals relative to the tonic.

1400 Intonation Table

- 1401 Minor Second
- 1402 Major Second
- 1403 Minor Third
- 1404 Major Third
- 1405 Perfect Fourth
- 1406 Tritone
- 1407 Perfect Fifth
- 1408 Minor Sixth
- 1409 Major Sixth
- 1410 Dominant Seventh
- 1411 Major Seventh
 - ± 1200 ct
 - +100 ct

The Values for Parameters 1401 to 1411 may be altered by up to 1200 ct (one octave) up or down, *relative to the notes of the equal-tempered scale*. If the

Dual Press

[1400] Intonation Table

- [1401] Minor Second
- [1402] Major Second
- [1403] Minor Third
- [1404] Major Third
- [1405] Perfect Fourth
- [1406] Tritone
- [1407] Perfect Fifth
- [1408] Minor Sixth
- [1409] Major Sixth
- [1410] Minor Seventh
- [1411] Major Seventh
- [1412] Name Int Table
- [1413] Save Int Table
- [1414] Delete Int Table
- [1415] Dump Int Table

Section VI

6.4 Pressure Map Editor Submenu

1412 Name Intonation Table

- Yes

Use this Function Parameter to name (or rename) the current Intonation Table. Press YES to initiate the naming sequence.

1413 Save Intonation Table

- Yes

Use this Function Parameter to save (store) an Intonation Table in RAM. Press YES to initiate saving.

1414 Delete Intonation Table

- Yes

Use this Function Parameter to delete (erase) the currently selected Intonation Table. Press YES to initiate deletion.

1415 Dump Intonation Table

- Yes

Press Yes to initiate a SysEx dump of the current Intonation Table.

EXITING THE INTONATION TABLE SUBMENU

Press PLAY to return to the Master Menu. If you've made any changes to the Intonation Table, you will be asked whether you want to save the Intonation Table before returning to the main Master Menu.

1500 Pressure Map

This is the Submenu heading.

1501 ppp

1502 pp

1503 p

1504 mp

1505 mf

1506 f

1507 ff

1508 fff

You'll use the VALUE buttons to assign a prs Value to each of these effect levels. "ppp" represents minimum effect, and "fff" is maximum effect. To best understand the relationship between the effect level and the prs Value, think of it as follows: the letters represent the amount of effect you will achieve with a given amount of pressure, scaled from 0 to 127. Thus, if you have a pressure map with ppp = 0, then you will get minimum effect when no pressure is applied. If ppp = 127, then you will get minimum effect when you are applying maximum pressure.

The best way to get an idea of appropriate settings is to select the Linear Pressure Map and use Parameters 1501 - 1508 to analyze the settings.

1509 Name Pressure Map (Name Prs Map? in display)

Once you've made changes to a Pressure Map, you'll want to give it a distinguishing name. Answer YES here, and you will be able to name the Pressure Map in the standard fashion. Once you name it, you can then save it using Parameter 1510. This will preserve the original Pressure Map (the one you started with before editing) as well. See Section 4.4.1 for information about the naming procedure.

1510 Save Pressure Map (Save Prs Map? in display)

This Parameter will allow you to save an edited Pressure Map to a RAM location with a unique number. Answer YES, and the display will automatically assign the next available number to the map. You can change the number using the PRO-GRAM buttons. When the number you want is showing in the display, press YES to confirm the save. If you attempt to save to an occupied RAM location, you will be asked if you want to replace the existing map.

1511 Delete Pressure Map
(Delete Prs Map? in display)

Answer YES here to delete the currently selected Pressure Map. Preset maps cannot be erased. If Confirmation (Master Parameter 029) is ON, you will be asked if you are sure you want to delete the map.

1512 Dump Pressure Map
(Dump Prs Map? in display)

Answer YES here to initiate a SysEx dump of the current Pressure Map.

EXITING THE PRESSURE MAP SUBMENU

Press PLAY to return to the Master Menu. If you've made any changes to the Pressure Map, you will be asked whether you want to save the Pressure Map before returning to the main Master Menu.

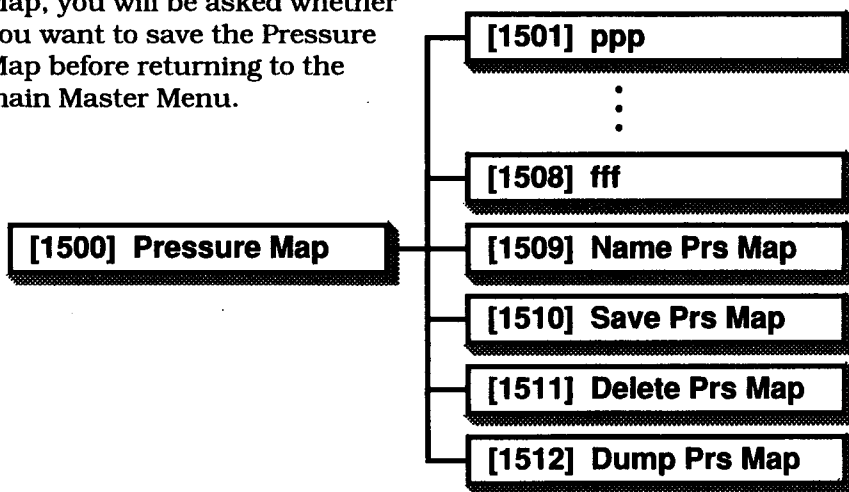

6.5 Default Control Sources Editor Submenu

This is the Submenu you'll use to change the characteristics of the temporary Performance Setup. Remember that every time you select a Program from the Bin Banks, the K1200 creates a temporary Performance Setup that defines several of the Program's performance features—like Split points, Pitch and Mod wheel assignments, and more.

By editing the Default Control Source parameters, you can define the performance configuration for every Program stored in the Bin Banks.

1600 Ctl Source

This is the Menu heading.

1601 Modulation Wheel Up

- MIDI 01 - 31, 64 - 95

This Parameter, along with Parameter 1602, determines the function of the Modulation Wheel in the temporary Performance Setup. The effects of deflecting the Mod Wheel up and down are independently programmable. Parameter 1601 defines the effect of deflecting the Mod Wheel up (away from

Section VI

you). Use either VALUE button to assign the control destination of Mod Wheel Up. The default Value is MWheel (MIDI 01).

1602 Modulation Wheel Down

- MIDI 01 - 31, 64 - 95

This Parameter defines the effect of deflecting the Mod Wheel down (toward you). The value you select for this Parameter may be the same as that for Parameter 1601, or it may be different. Use either VALUE button to assign a control destination. The default Value is Breath (MIDI 02).

1603 Switch Pedal 1

- MIDI 01 - 31, 64 - 95

This Parameter determines the assignment of Pedal 1 (the right pedal) in the temporary Performance Setup. Any switch pedal connected to the Pedal 1 jack on the K1200's rear panel will function according to the assignment you make here. The default setting for Pedal 1 is Sustain, but you may use either VALUE button to assign Pedal 1 to other control destinations.

1604 Switch Pedal 2

- MIDI 01 - 31, 64 - 95

This Parameter determines the assignment of Pedal 2 (the left

pedal) in the temporary Performance Setup. Any switch pedal connected to the Pedal 2 jack on the K1200's rear panel will function according to the assignment you make here. The default setting for Pedal 2 is Sostenuato, but you may use either VALUE button to assign Pedal 2 to other control destinations.

Note: Pedals 1 and 2 are affected by the automatic calibration performed by the K1200 at power-up. The status of the pedals at power-up determines their orientation. If no pedals are connected to the pedal jacks at power-up, the K1200 will interpret the pedal positions as "open" (up). With pedals connected and in the up position, the K1200 will calibrate similarly. If you power up while holding down a connected pedal (closed position), the calibration will be reversed, and the pedal will function in reverse of its normal function, or not at all. A reversed pedal can be a useful performance feature, if you have a pedal assigned to a function that you want to be on at most times, but off when you press the pedal. While this feature is useful, it can be puzzling if you are not aware that the calibration is reversed. Be certain when you power up that the pedals are in the proper position for your performance needs. If the orientation of the pedals becomes reversed, power

down and then power up again with the pedals in the desired position.

1605 Data Entry Slider

- MIDI 01 - 31, 64 - 95

This Parameter determines the assignment of the Data Entry Slider in the temporary Performance Setup. The default value is "Data" (MIDI 06), meaning that the Data Entry Slider is set to enter data into the K1200. By using the VALUE buttons you can change the Value of this Parameter to other control destinations. Changing the Value for this Parameter causes the Data Entry Slider to control other functions.

1606 Mono Pressure Transmit Mode (MonoPress in Display)

- Both
MIDI
Local
Off

This Parameter determines how mono pressure messages from the K1200's keyboard are interpreted by the temporary Performance Setup.

A Value of Both sends pressure signals to the K1200's internal sounds, and also sends mono pressure signals over the K1200's basic MIDI channel.

A Value of MIDI sends the pressure signals ONLY over the K1200's basic MIDI channel.

A Value of Local sends pressure messages ONLY to the K1200's internal sounds.

A Value of Off disables mono pressure entirely until another Performance Setup is selected.

EXITING THE CONTROL SOURCES SUB-MENU

Press PLAY to return to the Master Menu.

6.6 Program List (PList) Editing Submenu

You'll want to edit the PLists when using the K1200 with other MIDI instruments, whether they're sequencers, other synths, or effects modules. When the K1200 is a MIDI Slave, the Program Lists affect the way the K1200 responds to incoming MIDI Program Change messages. When the K1200 is the MIDI Master, the Program Lists enable you to select any Program number (0 to 999) from the K1200's front panel, and automatically send a "legal" MIDI Program Change number of 0 to 127 (1 to 128) from its MIDI Out port.

BASIC PLIST EDITING

The K1200 features ten Program Lists, each containing 100 Program numbers. These PLists are stored either in ROM (factory Presets) or RAM (User-defined).

If you're using your K1200 with other MIDI devices, you'll need to use the PLists in two cases: When you want to select a Program in the K1200 and, at the same time, send a Program Change number of 0 to 127 (1 to 128) to a receiving MIDI device; when you want the K1200 to receive a Program change number from 0 to 127 (1 to 128) and automatically select any Program number from 0 to 999.

The first four Program Lists (containing Program numbers 0 - 399) are preprogrammed for your convenience. The first two, Browser I and II, contain every one of the K1200's Programs, mapped to the List in a sequence that features the variety of the K1200's sounds as you scroll through the Program List. The Lists called Library I and II feature the same set of Programs, mapped to the Lists in a sequence that collects all sounds of a particular category (like piano) into groups.

List 5 (Program numbers 400 - 499) is called "RAM Progs." When you save a newly created Program, it will be mapped to

the first available Program number in this List—unless you update the Program List when the K1200 prompts you. If you update the Program List, the new Program will replace the previously selected Program (the one you edited to create the new Program), automatically mapping itself to the currently selected Program List.

Here's an example. Imagine you select Program 1, then enter EDIT Mode, and change the Soundfile. Then you rename the Program using the Name Program Parameter (#101). Next you select Parameter 102 Save Program?, and answer YES. The display says:

```
Save as ID# 255?  
My new Prog
```

You can use the PARAMETER buttons at this point to change the ID# that will be assigned to the new Program.

Since the display says "Save" and not "Replace," you know that there is no Program which already has ID# 255. You answer YES, and the display tells you that the Program has been saved as ID#255 (no Program number has been assigned yet).

After a second, the display asks you if you want to update the Program List. The List that will be updated is the List which contains the original Program

Section VI

number. The display also shows the Program number of the original Program (1, in this case), and the ID# of the original Program (**not** the ID# of the new Program). The K1200 is asking you this: "You selected Program number 1, whose ID# is 159 (or whatever), and edited it. You saved the edited Program as ID# 255, and asked me to update the Program List. Do you want me to assign your new Program—ID#255—to Program number 1, and remove the original Program from the Program 1 slot?" You answer YES. The List is instantly updated, and the K1200 returns to PLAY Mode.

If your MIDI system calls for a lot of Program mapping, you'll want to spend some time organizing your Program Lists for maximum efficiency. As a rule, for both transmitting and receiving Program Change messages, you'll want to edit the entries in the first List, Browser I. This is because it contains the Program numbers between 0 and 99, which are the numbers you need to use for most MIDI devices available today.

You can change the entries in any of the Lists, then save the List as List number 6 - 10—without replacing any of the preset Lists your K1200 arrived with. You can, however, replace the preset Lists with Lists of your own. The preset Lists are

not lost; they will reappear when you delete the Lists which "replaced" them. This is **not** true of Lists you create yourself, however. If you replace them, they're gone.

1700 ProgList

This is the heading for the Program List editor.

1701 Edit Entries

- Yes

When you select the Program List editing Submenu by answering Yes to Parameter 010, you arrive at Parameter 1701, which asks you if you wish to edit the entries in the currently selected MIDI Program List. (Make sure to use Parameter 009 to select the List you want to edit before entering the Program List editor.)

Answer Yes, and the display will look something like this :

```
Prog 1 = ID#143
Q Orchestra
```

The term "Prog" refers to the Program number as you normally think of it; it's the number of the Program as it appears when you select it in PLAY Mode.

The ID number is the memory address that the K1200 uses internally. Each Program (Object of type PROG) has only

one ID number. **It is this number which is associated with the Program name you see on the display's lower line.**

The display is telling you this: "The Program List entry you are looking at contains the Program called 'Q Orchestra.' Its Object ID number is 143, and it is stored as Program 1." In other words, when you return to PLAY Mode, you will find the Program 'Q Orchestra' by selecting Program number 001.

If you want to edit this entry, use the VALUE buttons to scroll through the list of ID numbers. In other words, use the VALUE buttons to change the actual sound assigned to Program number 1. For example, let's say you press the VALUE UP button. The display will change to:

```
Prog 1 = ID#144
Nuageux
```

You're telling the K1200 this: "Take the Program called 'Nuageux,' whose ID number is 144, and 'map' it to Program number 001." If you save this List, then return to PLAY Mode and select Program number 001, you'll find that it is now Nuageux, and no longer Q Orchestra.

Use the PARAMETER buttons to select a different Program number (this doesn't change

the List, it merely lets you look at a different entry in the List). Dual presses of the PARAMETER buttons jump to the first Program number in the List.

Use the MENU DOWN button to shift the currently displayed ID#—and all ID#s “below” it on the List—“down” one space in the Program list, inserting ID# 0 in the empty space. If, for example, the display reads

“Prog 1 = ID# 159,”

and you press MENU DOWN, the display will change to

“Prog 1 = ID#0.

ID#159 will now be assigned to Prog 2, etc. If there are no empty spaces at the end of the list, the highest-numbered entry will be deleted.

Use the MENU UP button to delete the currently displayed ID# from the displayed position in the List. Using the same example, if you press MENU UP instead of MENU DOWN, ID#159 will be removed from the List, and all ID#s “below” it on the List will be moved “up” one Program number.

When you have made all the changes you want to, press YES, and you will return to the “Edit Entries?” display. You may then press the PARAMETER UP button to select Parameter 1702 (Name ProgList?).

1702 Name ProgList

- Yes

Enables you to give a unique name to the List you have edited, prior to saving. This procedure is similar to the naming procedure that is described in Section 4.4 of the *Performance Guide*.

1703 Save ProgList

- Yes

Enables you to save a newly-edited List to RAM. The saving procedure also is described in the *Performance Guide*.

1704 Delete ProgList

- Yes

Deletes the currently selected List. See the *Performance Guide* for a description of the deletion process.

1705 Dump ProgList

- Yes

Press Yes to initiate a SysEx dump of the currently selected Program List.

EXITING THE PLIST SUBMENU

Press PLAY to return to the Master Menu. If you’ve made any changes to the Plist, you will be asked whether you want to save the Plist before returning to the main Master Menu.

SECTION 6.7 Bin Map Editor Submenu

You remember that you’re able to store Programs, PSetups, and several other Objects in the Bin Banks: three Banks of ten “addresses” which can be selected using the alphabetic and numeric buttons. One set of thirty such addresses can be stored as a Bin Map. The Bin Map Editor allows you to create and store additional Bin Maps, which you can select using Master Parameter 011, or from the front panel (using buttons 0 and 1 together).

The first step in editing Bin Maps is selecting the Bin Map you wish to edit (if you select it from the front panel, it will remain selected as you enter EDIT Mode).

When you answer YES to Parameter 012 Edit BMap? you will enter the Bin Map Editor Submenu. To edit the current BMap, answer YES to Parameter 1801 Edit Entries? The display will show you something like this:

```
A0 Program      1
Q Orchestra
```

This tells you that you are looking at Bin 0 in Bank A of the current Bin Map. The entry at A0 is a Program, and its number is 1. The two elements of this entry which you can

Section VI

change are the type of Object which is stored there (Program, PSetup, VelMap, etc), and the number of the Object of the selected type.

To change the number of the currently displayed Object, use the PROGRAM buttons. Dual presses scroll (by hundreds) to the beginning of each PList. In the above example, you would use the PROGRAM buttons if you wanted to find another Program to store in Bin Bank A0.

To change the type of Object stored in the current Bin Bank, use either MENU button. For example, if you wanted to store a PSetup in A0 instead of a Program, you would use the MENU buttons to select the PSetup Object type.

Press an alphabetic button (A, B, or C) to select a different Bank within the current Bin Map. Use the numeric buttons to view what's stored in the different Bins within the current Bank.

When you've made your changes, press Play to exit the Submenu, then select Parameter 1802 to name the edited BMap. Then save it using Parameter 1803.

The preprogrammed Bin Bank assignments give you a sample of the different ways you can use Bin Maps to enhance your performance flexibility.

1800 Bin Btn Map

This is the Menu heading.

1801 Edit Entries?

- Yes

Answer YES to this Parameter when you want to change a Bin Map entry.

1802 Name BMap?

- Yes

Answering YES here starts the standard naming sequence as described in Section 4.4.1.

1803 Save BMap?

- Yes

Answering YES here starts the standard saving sequence as described in Section 4.4.2.

1804 Delete BMap?

- Yes

Answering YES here starts the standard deletion sequence as described in Section 4.4.3.

1805 Dump BMap?

- Yes

Answering YES here initiates a SysEx dump of the currently selected Bin Map.

EXITING THE BIN MAP SUBMENU

Press PLAY to return to the Master Menu. If you've made any changes to the Bin Map, you will be asked whether you want to save the Bin Map before returning to the main Master Menu.

SECTION 6.8 Performance Setup Editor Submenu

You'll use the Performance Setup Editor to customize one or many performance configurations for your K1200. Performance Setups allow you to split the keyboard into three regions, and transmit on a different MIDI channel in each region, with independent control assignments for each region.

Once you have defined a Performance Setup (PSetup), you can save it and select it quickly from the Bin Banks—instantly reconfiguring your K1200 and connected MIDI devices.

Your K1200 arrives with three PSetups stored in ROM. Two of them have been included to give you ideas for creating your own PSetups. The other, called "current," is what we call the default PSetup. Whenever you recall a Program from (or store one to) a Bin Bank, the K1200 automatically selects this default PSetup. The Program you just stored is then assigned to the center region of this PSetup.

If you edit the "current" PSetup, you can save it as a User-defined PSetup. The original "current" PSetup will remain unchanged. You can change the characteristics of the "current" PSetup by using Parameter 043 "Edit Dflt Ctls?"

Entering the PSetup Editor Menu

To enter the PSetup Editor Menu, starting from PLAY Mode:

Press PLAY/EDIT

Press CHANNEL/MENU DOWN twice to get to the Master Parameter Menu.

Press VALUE DOWN twice to reach Parameter 044 Edit PSetup?

Answer YES. The display will resemble this:

C-PSetup 2019
MIDI Channel 1

Selecting a Region to edit

Once you've entered the PSetup Editor Menu, you can use the LAYER button to scroll through the Regions in the current Setup. The first character in the display will indicate which Region is selected (L for Left, C for Center, R for Right). Also see Section 3.4, which tells you how to select Regions for performance control while in PLAY Mode.

Selecting Parameters to edit

When you enter the PSetup Editor Menu, you'll see one of 21 Parameters in the range from 2000 to 2021. These are the Parameters you will use to define your Performance Setups. Use the PARAMETER UP and DOWN buttons to scroll through the list.

PSetup Editor Menu Parameters 2000 - 2004

Parameters 2000 through 2004 affect the entire Performance Setup. With the exception of Parameter 2000, they are "administrative" Parameters which allow you to name, save, delete, or SysEx dump the currently selected PSetup.

2000 C-PSetup

This is the Menu Heading for the PSetup Editor Menu, and doesn't permit any actual programming.

2001 Name Setup?

• Yes

Once you've edited your Performance Setup, you'll give it a name using this function Parameter. Answer YES here to begin the standard naming sequence which is explained in Section IV, Basic Editing. If you answer NO to this Parameter, you'll move on to the next Parameter.

2002 Save Setup?

• Yes

Normally, when you create Performance Setups, you'll do the editing first, then name the Setup, and finally save it to a RAM location. You can edit, name, and save in any order you like, but it makes sense to name the Setup before saving it, regardless of when you do your editing. This prevents you from creating multiple Performance Setups with the same name, which can get confusing.

Section VI

To save a Performance Setup, simply answer YES to the "Save Setup?" prompt. This begins the saving sequence, as described in Section IV.

If you answer NO to the "Save Setup?" prompt, you'll move on to the next Parameter.

2003 Delete Setup?

- Yes

Answer YES to remove the Setup from RAM. If Confirmation (Master Parameter 029) is ON, the K1200 will ask you if you are sure you want to delete the Setup. Press YES again to delete the Setup. Once a Setup is deleted, it's gone.

If you have ObjectMover, you can save Setup Objects just like any other Object. This is an excellent way to back up your work.

If you answer NO to this Parameter, (and to the "Are you sure?" prompt if Confirmations are on), you'll move on to the next Parameter.

2004 Dump Setup?

- Yes

Answering YES here begins a System Exclusive dump of the currently selected Performance Setup. This is another way to

save your Performance Setups outside the K1200.

Answering NO to "Dump Setup?" moves you to the next Parameter.

Region Modes

Parameters 2005 through 2010 let you specify how the K1200 handles the data received from each keyboard Region. Once you've selected a Parameter in this section of the Menu, you can use the LAYER button to scroll through each of the Regions in the Setup, and see the different Values for each Region.

Each Region Mode Parameter allows one of four Values: None, Local, MIDI, and Both. A Value of "None" is the same as turning that Parameter off; the information controlled by that Parameter is not used.

A Value of "Local" means that the information controlled by the selected Parameter is used by the K1200 to control its own sound. A Value of "MIDI" indicates that the information controlled by the selected Parameter is transmitted at the K1200's MIDI Out, but is not used by the K1200.

A Value of "Both" causes the information controlled by the selected Parameter to be sent to both the K1200 **and** connected

MIDI devices. This is the default Value for each of the Region Mode Parameters.

Region Modes and Continuous Control Information

Although the default Value for each of the Region Modes is "Both," a restriction applies to the following Parameters: Press Mode, Pitch Mode, and Wheel Mode. These continuous controls are limited to use with only **one** Region at a time. This is because of the large amount of MIDI data generated by continuous controls. If each Region were able to send a different continuous control message, on a different channel, for each movement of the Pitch or Mod wheels, you could easily generate more MIDI data than any of your MIDI devices could receive and respond to.

To avoid MIDI overflows, then, only one Region at a time can be enabled to send continuous control information. Since the default Values for Press Mode, Pitch Mode, and Wheel Mode are all "Both," the K1200 looks at the assignment of each Region for each Parameter, and automatically makes the control assignment to the lowest-numbered Region which has a Value other than "Off." The Center Region is the lowest-numbered Region, and the Left Region is the highest.

When you change any of the currently selected Region's continuous control mode Values from Off to anything other than Off, the K1200 checks the other Regions' corresponding control mode Values. If any of them is not already set to Off, the K1200 will automatically set the Values of that continuous control to Off in the other regions.

Note that this doesn't affect the actual MIDI Control Number assignments of the controls for each Region. You can assign them anywhere you like, but you can use only one of them at a time.

Here's an example. Suppose you create a PSetup with a different Program in each Region. You choose three Programs which have three different effects preprogrammed to respond to Mono Pressure—Vibrato Rate for the Program in the Left Region, Tremolo Depth for the Program in the Center Region, and Envelope Control for the Program in the Right Region. If you enter the PSetup Editor Menu and examine the Values of the Pressure Mode Parameter (Parameter 2006) for each Region, you'll notice that even though they all may be set to "Both," you can hear only one effect triggered by Mono Pressure—in this case, probably a change in Tremolo Depth. This is because the lowest-

numbered Region—the Center—has a Value other than Off for Pressure Mode, so the K1200 assigns its Mono Pressure effect according to the Center Region, ignoring the other Regions' assignments.

If you set a non-Off Value for the Pressure Mode Value for any of the Regions, the other Regions' Pressure Mode Values will be set automatically to Off.

PSetup Editor Menu Parameters 2005 - 2010

2005 Keyboard Mode Keybd mode in display)

- Local
MIDI
Both
Off

The keyboard mode determines how the K1200 deals with MIDI data sent from the keyboard in the currently selected Region.

Select a Value of Local when you want the current Region to trigger notes in the K1200 only, sending no MIDI note data to other devices.

Select a Value of MIDI when you want the current Region to send MIDI note data to connected devices, but not to the K1200. In this case, the current region would function like an individual MIDI controller.

Select a Value of Both when you want the current Region to trigger K1200 sounds **and** transmit MIDI note data to connected devices. This is the default Value.

If you choose "Off," you will filter MIDI note data from the Region to the K1200 itself, as well as to any connected MIDI devices. You would choose "Off" to completely deactivate the notes from the currently selected Region. You can do this to silence a Region without changing the mode for each of the other Parameters. As a rule, however, you're unlikely to want to use this Value.

2006 Pressure Mode (Press Mode in display)

- Local
MIDI
Both
Off

Select "Local" when you want only the K1200 to respond to Mono Pressure. "MIDI" causes only those MIDI devices connected to the K1200 to respond to the current Region's Mono pressure signals. Use "Both" to trigger Mono Pressure effects in both the K1200 and connected MIDI devices (this is the default Value). A Value of "Off" disables Mono Pressure in the current Region.

Section VI

2007 Pitch Mode

- Local
MIDI
Both
Off

This Parameter determines where the currently selected Region sends information from the Pitch Wheel. Pitch changes can be sent to the currently selected Region of the K1200 only (Local), can be sent only via MIDI to the device controlled by the currently selected Region (MIDI), can be sent to both the K1200 and MIDI (the default), or can be ignored (Off).

2008 Wheel Mode

- Local
MIDI
Both
Off

Use this Parameter to determine where the currently selected Region sends information from the Mod Wheel and Data Slider. Mod Wheel changes can be sent to the currently selected Region of the K1200 only (Local), can be sent only via MIDI to the device controlled by the currently selected Region (MIDI), can be sent to both the K1200 and MIDI (the default), or can be ignored (Off).

2009 Pedal Mode

- Local
MIDI
Both
Off

Since the foot pedals are switch controls, and therefore send single MIDI events rather than the stream of events generated by continuous controls, there is no danger of MIDI overflow from the foot pedals. Consequently, each Region can have a unique Pedal Mode setting, which does not interfere with the Pedal Mode setting of the other Regions.

Use this Parameter to determine where the currently selected Region sends information from both of the foot pedals. Pedal information can be sent to the currently selected Region of the K1200 only (Local), can be sent only via MIDI to the device controlled by the currently selected Region (MIDI), can be sent to both the K1200 and MIDI (the default), or can be ignored (Off).

2010 PChange Mode (Program Change)

- Local
MIDI
Both
Off

This Parameter determines where the currently selected

Region sends Program Change information received either from the K1200's front panel or at the K1200's MIDI In port. Each Region can have its own PChange mode assignment. Program Change commands can be sent to the currently selected Region of the K1200 only (Local), can be sent only via MIDI to the device controlled by the currently selected Region (MIDI), can be sent to both the K1200 and MIDI (the default), or can be ignored (Off).

PSetup Editor Menu Parameters 2011 - 2017

The next group of Parameters affects the entire PSetup. In other words, you cannot set separate Values for these Parameters in each PSetup Region. In fact, if you use the LAYER button to scroll through the Regions while one of these Parameters is selected, you'll see that the Values do not change. If you change a Value, then select another Region, you'll see that the new Value remains in effect for all three Regions.

The best way to think of the group of Parameters from 2011 to 2017 is to consider them as Parameters governing the entire PSetup. Whatever Value you set for one of these Parameters will be the Value used by the "active" Region(s). The active

Regions are determined by the modes defined by Parameters 2005 - 2010—a Region is active if it is not set to Off (Remember that only the lowest Region—from left to right—can be active for continuous controls, even if the Values for more than one Region are set to something other than Off).

For each of the Parameters in this group, you can use the VALUE UP/DOWN buttons to scroll through the list of available Values. Dual presses will take you to MWheel (MIDI 01), Ctl A (MIDI 16), Sustain (MIDI 64), Ctl E (MIDI 80), and ProgUp (MIDI 96).

2011 Mod Wheel Up

- MIDI 01 - 31, 64 - 95

This Parameter determines the effect on (one of the Regions of) the current PSetup when you deflect the Mod Wheel up (away from you). The default Value is MWheel (MIDI 01).

2012 Mod Wheel Down

- MIDI 01 - 31, 64 - 95

This Parameter determines the effect on (one of the Regions of) the current PSetup when you deflect the Mod Wheel down (toward you). The default Value is Breath (MIDI 02).

2013 Pedal 1 Destination

- MIDI 01 - 31, 64 - 95

Use this Parameter to define what the actual function of Foot Pedal 1 will be for the PSetup. The default Value is Sustain.

2014 Pedal 2 Destination

- MIDI 01 - 31, 64 - 95

Use this Parameter to define what the actual function of Foot Pedal 2 will be for the current PSetup. The default Value is Sostenuto.

2015 Slider

- MIDI 01 - 31, 64 - 95

Use this Parameter to program the Data Entry Slider to control various effects in the current Region. The default Value is Data, which enables you to use the Slider to change the Value of some Parameters. You can, however, use the Slider very effectively by assigning it to one of the other control sources in the list.

2016 Low Split

- C0 - C8

This Parameter enables you to set the lower of the two split

points which define the current Performance Setup's three Regions. Simply use either of the VALUE buttons to change the displayed Value. The Low Split cannot be set above the High Split.

2017 High Split

- C0 - C8

Use this Parameter to set the higher of the two split points which define the current Performance Setup's three Regions. Simply use either of the VALUE buttons to change the displayed Value. The High Split cannot be set below the Low Split.

2018 Set Split Points?

- Yes

Answering YES to this function Parameter causes the K1200 to prompt you to strike the first key, which will become the lowest key in the center Region. As soon as you strike the first key, you will be prompted to strike the second key, which will define the highest key in the center Region. When you strike the second key, the display will return to the "Set Split Points?" display. Answering NO to this Parameter will move you to the next Parameter.

Section VI

2019 MIDI Channel

- Off, 1 - 16

With this Parameter you'll set the MIDI channel used by the currently selected Region. A Value of Off shuts the Region off completely.

2020 Transpose

- ± 60 ST

Use this Parameter to transpose the pitches of notes played in the currently selected Region. The default Value is no transposition. You can transpose a Region up or down as much as five octaves (60 ST). The transposition you apply to a Region affects the K1200's internal sounds, as well as the note information sent via MIDI. Regional transposition is added to any Master transposition which may be in effect.

2021 Program Number

- None, 0 - 99

With this parameter you can assign a specific Program number to the currently selected Region. When you select

up a Performance Setup, the selected Program Change number is sent—locally, via MIDI, to both, or not at all—according to the Value you set for PChange Mode, Parameter 2010.

A Value of None means that no Program Change message will be sent—regardless of PChange Mode—when the PSetup is selected. This is useful for selecting different PSetups without disturbing the rest of your configuration.

The Value of Parameter 003 can affect this feature as well. If you're sending Program Change messages to another Kurzweil 1000 Series synthesizer equipped with Version 5 software, you'll want to set Parameter 003 to "Ext." For other MIDI devices, "On" will probably work better.

EXITING THE PSETUP SUBMENU

Press PLAY to return to the Master Menu. If you've made any changes to the PSetup, you will be asked whether you want to save the PSetup before returning to the main Master Menu.

Section VII

PROGRAM MENU

The Parameters in the Program Menu affect all Layers of the current Program. (In Edit Mode, the Program number appears in the upper right corner of the display.)

100 Program

This is the heading for the Program Menu.

101 Name Program

- Yes

This Parameter permits you to name (or rename) the current Program. Press YES to initiate the naming sequence. (See the *Performance Guide* for a review of naming Objects.)

102 Save Program

- Yes
- No

Use this Parameter to save Programs in RAM. For more information on saving Objects, see the *Performance Guide*.

103 Delete Program

- Yes
- No

Enables you to delete the current Program. An answer of YES initiates the deletion sequence. See the *Performance Guide* for a review of deleting Objects.

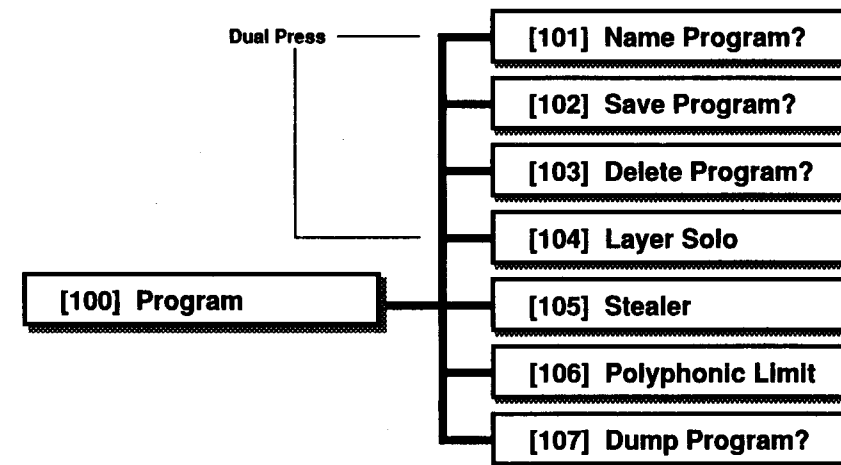

104 Layer Solo

- Off
- Solo
- Mute

This Parameter enables the current Layer of the current Program to be heard by itself, or to be silenced.

With a Value of Off, you will hear all Layers of the current Program. (This is the default.)

With a Value of Solo, you will hear only the current Layer.

With a Value of Mute, you will hear all Layers *except* the current Layer.

The Value of this Parameter remains constant as long as you stay in Edit Mode and do not save the Program or change Compiled Effects. If you set the Value to Solo, then as you

change the current Layer with the LAYER button, you will hear each Layer by itself. You may also move to the Layer Menu, for example, and hear the effects of edits to the Layer.

There are several actions which will cause the Value of Parameter 104 to revert to Off:

- Returning to Play Mode
- Saving the current Program
- Adding or deleting Layers
- Changing from one Compiled Effect to another

Taking any of these actions may surprise you if you have forgotten that you have been soloing or muting Layers, since the sound of your Program will change. It is therefore a good idea to get in the habit of selecting the Layer Solo Parameter and setting it to Off before saving, exiting Edit Mode or changing Compiled Effects.

Section VII

105 Channel Stealing

- Mono
- Poly
- Poly 1
- Poly 2

Enables you to choose between four channel-stealing algorithms.

“Channel stealing” refers to a loss of notes that occurs when the polyphonic limit of a synthesizer is exceeded. Depending on your playing style, you may experience channel-stealing at various points in your performance. Unless you layer heavily, you’ll rarely encounter it. If you do, however, you can adjust the Value of this Parameter and possibly avoid channel-stealing.

Mono makes the K1200 a monophonic machine *in the musical sense*: it will play only one note at a time (though will still produce a stereo output signal). You may find this useful if you are using your K1200 in a multi-synth setup playing a solo that needs to be monophonic.

Poly is the default Value. With a Value of Poly, the stealer uses a complex software routine to determine the most musical way to steal notes when it becomes necessary. This is the Value that you will be most likely to use.

Poly 1 uses a slightly different routine, stealing the same note if it is retriggered before the first note dies out. For example, in a three-Layer Program, one key-strike triggers three notes in your K1200 using audio channels 1, 2, and 3. If you strike the same key on your controller before the first three notes have died out, the K1200 will reuse channels 1, 2, and 3, stealing the first three notes and replacing them with the second three.

Poly 2 operates much like Poly 1, but will steal the same note(s) half as often. Continuing the example of a three-Layer Program, if you struck Middle C, you would trigger audio channels 1, 2, and 3 in the K1200. Strike Middle C a second time (before the first notes die out), and you will trigger audio channels 4, 5, and 6 (Poly 1 would have retriggered 1, 2, and 3, stealing three notes). Strike Middle C a third time (before any notes have died out), and the K1200 will retrigger audio channels 1, 2, and 3, stealing the first three notes.

106 Polyphonic Limit

- Off
- 1 to 24
- +8

Enables you to set the maximum number of notes that can be played simultaneously in the current Program.

A Value of Off means that there are no restrictions on the number of notes dedicated to a given Program, other than the polyphonic limit of the K1200.

A Value other than Off determines the maximum number of simultaneous notes for the current Program.

107 Dump Program

- Yes

Answer Yes to initiate a SysEx dump of the current Program information.

Section VIII

L A Y E R M E N U

The Parameters in the Layer Menu control the characteristics of individual Layers of the current Program.

You must select a Layer (using the LAYER button) in order to edit it. If you change Layers within this menu, then subsequent edits will affect the newly-selected Layer.

200 Layer

This is the heading for the Layer Menu.

201 New Layer • Yes

Use this Parameter to add a new Layer to the current Program. See Section 4.2.1 of the *Performance Guide* for further information.

202 Duplicate Layer • Yes

This Parameter creates a copy of the current Layer (if space is still available in the current Program). The duplicated Layer takes the next available Layer number, and becomes the current Layer.

Press YES if you wish to duplicate the current Layer.

There are two cases in which the K1200 will not allow you to duplicate Layers. The current Program may already contain

the maximum of four Layers, or the Compiled effect assigned to the current Layer may require too many Modules for the K1200 to duplicate (see Section V). In either case, you will be alerted that there are no more Layers available.

NOTE — Some Programs having preset Compiled Effects (Chorus 2, for example) occupy two or more inseparable Layers. If an Effect requiring two Layers is selected for the current Layer in the current Program, then the Duplicate Layer Parameter will copy both Layers. (That is, the original Layer will actually comprise Layers 1 and 2, and duplicating it will create Layers 3 and 4.) If the Effect requires more than two Layers (as some do), the K1200 will be unable to duplicate the Layer.

203 Import Layer • Yes

Imports an existing Layer, from any Program, into the current Program.

The Layer you select is duplicated and inserted as the next-highest Layer in the Program that you are editing (as long as you have not reached your maximum of four Layers). Importing Layers allows you to move your favorite Layers from Program to Program without having to recreate them from scratch.

If the Program you are importing into uses one or more global Modules (gLFO or gASR), then Programs using the same Module(s) will not appear as you scroll through the Program List.

Pressing YES will begin the importing sequence. See Section 4.2.1 of the *Performance Guide* for a description of the procedure.

204 Clean Layer • Yes

Deletes all Effects (Compiled or Modular) associated with the current Layer.

If the Layer is at the Compiled Effects Level, the Effects revert to "None." The Amplitude Envelope for the Layer, if defined, is deleted (see Section 9.6).

If the Layer is at the Modular Effects Level, all local Effects Modules are deleted. If the current Layer is the only Layer in the Program, then all global Modules will also be deleted (see Section IX).

Pressing YES will begin the Layer cleaning sequence. Press NO to abort the sequence and return to Parameter 204, or press either PARAMETER button to select another Parameter.

Section VIII

Dual Press

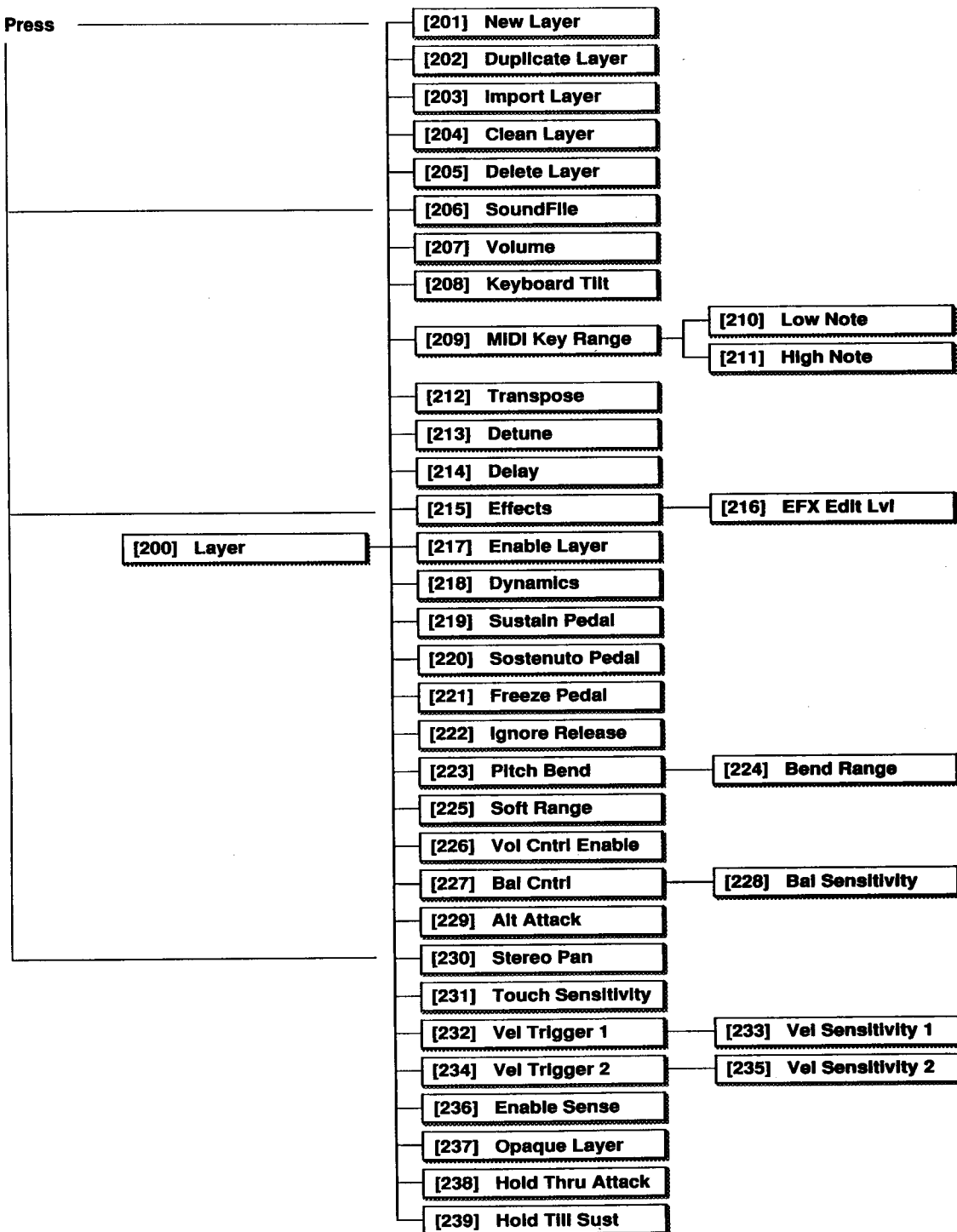

205 Delete Layer

- Yes

Deletes the current Layer and renumbers the remaining Layers. A deleted Layer cannot be retrieved.

Answer YES to this Parameter in order to remove a Layer from a Program. If the current Program contains only one Layer, the display will notify you and then will return to the "Delete Layer?" display. (A Program must contain at least one Layer to exist; you can't remove the only Layer in a Program.)

206 Soundfile

- Soundfile List

Selects one of many possible Soundfiles for the current Layer. A Soundfile is the sampled sound data from which a Layer is constructed.

207 Volume

- ±48 dB
- +6 dB

Allows you to set the Volume (loudness) of the current Layer. Use this Parameter to balance Layers against each other.

Keep in mind that a Soundfile played at normal full volume (MIDI velocity = 127 and Amplitude Envelope reaches 100%) has 3–4 dB of headroom in which to get louder. Adjusting Parameter 207 to a Value

greater than this will use up headroom quickly, "flattening" the volume curve's upper limit.

208 Keyboard Tilt

- ±48 dB
- +6 dB

Enables you to assign a progressive change in volume from the lowest note to the highest note in the current Layer.

For example, if the current Layer spans a keyboard range from C2 to C7 and you set the Value of this Parameter to +36 dB, then C7 will play 36 dB louder than C2 (if you strike both keys with equal force), and there will be a gradual increase as you ascend the scale.

A negative Value causes higher notes to be softer than lower ones.

209 Set MIDI Range

- Yes

Defines the area of the MIDI keyboard over which the current Layer will play, by prompting you to strike two keys to establish the low and high notes for the current Layer. The range will include the lowest key you struck, the highest key you struck, and all keys in between.

Once you have set the MIDI range for the current Layer, you can check and edit your Values using Parameters 210 and 211.

210 Low Note

- C0 to C8
- +1 octave (12 ST)

Displays the lowest key of the defined range for the current Layer and allows you to edit it.

The Value is an alphanumeric character representing the keys of a MIDI controller. The letter (A, B, C, etc.) refers to the notes of the chromatic scale. Black keys (e.g. C-sharp) are represented by a letter and the symbol "#."

The numeral indicates the octave number. For example, Middle C is represented as C4. The F-sharp above Middle C is represented as F#4. The highest C on a standard piano is C8, and the lowest is C1. All keys below C1 are in Octave 0.

211 High Note

- C0 to C8
- +1 octave (12 ST)

Displays the highest key of the range for the current Layer and allows you to change it. Parameter 211 operates in exactly the same fashion as Parameter 210.

Note — The Values you set for Parameters 210 and 211 determine how the display wraps when you execute a dual press of the VALUE buttons. The available Values for Low Note will not exceed the Value set for

Section VIII

High Note, and will wrap to C0 before reaching this limit. The available Values for High will not go below the Value set for Low Note, and will wrap from C8 to the Low Note Value.

212 Transpose

- ± 60 ST
- +1 octave (12 ST)

Transposes the current Layer in intervals of one semitone (ST). Each layer may be transposed up or down a maximum of five octaves.

Transposition allows you to set the pitch of a given Layer's Soundfile to a realistic range on the MIDI keyboard. It also allows you to create various intervals between the pitches of different Layers in a Program.

213 Detune

- ± 100 ct
- +10 ct

Adjusts the pitch of the current Layer up or down as much as one semitone in steps of 1 ct (1/100th semitone). A Value of "0" indicates no detuning.

Detuning is used to alter the pitches of Layers in a Program relative to each other. You can use Parameter 213 to create a chorus effect, for example, by creating multiple Layers using the same Soundfile and detuning each Layer slightly relative to the others.

Detuning can also be used to equally sharpen or flatten all of the Layers within a Program. This will change the pitch of that Program relative to other Programs, without affecting the overall tuning of the K1200.

214 Delay

- 0.000 s to 10.000 s
- Varies depending on the Value range

Postpones the beginning of the sound in the current Layer. You can use Parameter 214 to create time-delay effects such as echos and strums, or to create Programs that build in density over the duration of a sustained note.

215 Effects

- None
- Vibrato
- Delay Vibrato
- Tremolo
- Delay Tremolo
- Leslie
- Chorus 2
- Tremolo 2
- Vibrato/Chorus 2
- Phaser 2
- Leslie 2
- Chorus 3
- Echo 3

Allows you to select from the list of Compiled Effects when the K1200 is set to operate at the Compiled Effects Level (see Section 4.3 of the *Performance Guide*).

216 Change Effects Edit Level

- YES

Selects either Compiled or Modular Effects Levels for the current Layer.

Within any one Program, each Layer may have a different set of Effects. While Modular and Compiled Effects can exist on different Layers in the same Program, however, you must choose one or the other for each individual Layer.

When Parameter 216 has been used to change to Compiled Effects, the characters "FX" and the name of the selected Effect will appear in the lower line of the display for Parameter 215. When Parameter 216 has been used to change to Modular Effects, the word "Modular" will appear as the Value for Parameter 215.

Press YES at Parameter 216 to change Effects Levels.

If you answer NO to the next prompt, you will remain at the current Effects level and the display will return to "Chg FX Edit Lvl?"

If you answer YES, the display will ask if you are sure (as long as you haven't turned off the confirmations). At this point, an answer of NO aborts the change and returns you to the "Chg FX Edit Lvl?" display, while YES puts the change into effect.

Changing from Compiled to Modular Effects enables you to study the Parameters of the current Compiled Effect (see Section 10.8).

217 Enable Layer

• Control Source List

Allows you to enable/disable the current Layer, or assign a MIDI Control Source to do so. A disabled Layer becomes silent.

A Value of OFF disables the current Layer, while a Value of ON enables it.

A Value assigned from the Control Source List permits you to toggle the Layer on and off, depending on the status of the Control Source you assign. For example, if you select a Value of MPress, then the current Layer will play only when aftertouch is applied.

Note — Program Layers are either fully on or fully off. Assigning a continuous Control Source to this Parameter will not fade the Layer in gradually; rather, the Layer will be enabled once the Control Source exceeds its midpoint.

218 Dynamics

- 0 to 90 dB
- +6 dB

Limits the dynamic range of the current Layer.

The term “dynamic range” refers to the ratio between the loudest and softest sounds that the Layer can produce. For example, a Value of 60 means that the loudest sound you may trigger for the current Layer will be 60 dB louder than the softest sound.

A Value of 0 will create a Layer with no dynamic range: MIDI Velocity will not affect the loudness of the Layer (though Velocity may still affect the timbre of the Soundfile). A Value of 90 produces a Layer with the maximum dynamic range.

219 Sustain Pedal

- On
- Off

Enables/disables the function of the sustain pedal for the current Layer.

Select a Value of Off if you want the current Layer to ignore sustain pedal signals from your MIDI controller.

You can achieve interesting effects by setting Parameter 219 On for some Layers and Off for others. When you strike a chord and then release the keys with the sustain pedal pressed, all Layers with Parameter 219 set to On will continue to play, while those set to Off will begin their release segments.

220 Sostenuto Pedal

- On
- Off

Enables/disables the function of the sostenuto pedal for the current Layer.

Select a Value of Off if you want the current Layer to ignore sostenuto pedal signals from your MIDI controller.

If Sostenuto Pedal is enabled, then all notes whose keys are down at the time the pedal is pressed will be sustained for their natural duration.

221 Freeze Pedal

- On
- Off

Enables/disables the function of the freeze pedal for the current Layer.

Select a Value of Off if you want the current Layer to ignore freeze pedal signals from your MIDI controller.

With Freeze Pedal enabled, when you press the freeze pedal (assuming you have assigned one of the switch pedals to control the Freeze function), all notes sounding at the time the pedal is pressed will be “frozen” and will sustain without change until the pedal is released — regardless of their normal decay settings.

Section VIII

Combinations of Layers with Freeze Pedal enabled and disabled will allow you to “freeze” some Layers while others continue to play the notes that you strike.

Note: You must also set the Values of the Parameters for Pedals 1 and 2 (Master Parameters 1603 and 1604, or 2013 and 2014) to the function that you wish to control with those pedals.

222 Ignore Release

- Off
- On

Allows the current Layer to respond to, or ignore, MIDI Note Off events (the release of individual keys).

Select a Value of Off, and the current Layer will respond normally to the release of keys. This is the default.

Select a Value of On, and the current Layer will ignore the release of keys: notes will continue to sound as though you were still holding down the keys that triggered them. Notes with natural decay will eventually die out, but notes with no decay (such as organ and trumpet) will sustain indefinitely. You therefore normally should not set Ignore Release to “On” for non-decaying sounds.

223 Pitch Bend

- Off
- Key
- All

Enables/disables Pitch Bend control of the current Layer.

A Value of Off causes the current Layer to ignore pitch bend signals.

A Value of Key will allow pitch bend *only* on notes whose triggers are on (keys held down) when the pitch bend is activated. Notes held with Sustain, for example, will not be affected. Pitch Bend will operate on affected notes until they are released.

A Value of All will allow pitch bend on all notes which are sounding when the pitch bend signal is sent, including notes whose keys are actually pressed, as well as notes which are sounding as a result of a Control function or a long release.

224 Bend Range

- ±6 QT
- +6 QT

Sets the amount and direction of pitch bend for the current Layer.

The numerical value of Parameter 224 limits the amount of bend caused by a full throw of the Pitch wheel. The maximum is six quartertones (QT), which

is the same as three semitones (a minor third). The step size of one quartertone allows you to achieve subtle, microtonal pitch bends.

Negative Values reverse the Layer’s response to the pitch wheel: if you normally push to bend pitch up, a negative Value will cause a push to bend pitch down.

225 Soft Range

- ±48 dB
- +6 dB

Determines the amount of damping (decrease in volume) or boosting (increase in volume) of the current Layer when a switch pedal assigned to Soft is pressed.

A positive Value will reduce the volume of the current Layer when the soft pedal is pressed. A negative Value will boost the volume of the current Layer when the soft pedal is pressed, while a Value of 0 has no effect on the sound.

226 Volume Control Enable

- On
- Off

Enables/disables control over volume for the current Layer by any MIDI control source that can be assigned to MIDI Control Number 7. The ability to control Layer volume independently allows you to fade individual Layers in and out.

A Value of On means that you may control the volume for the current Layer via MIDI, while a Value of Off causes the current Layer to ignore any volume control signals.

227 Balance Control
 • Control Source List

In a single-Layer Program, this functions as a MIDI Layer Volume Control. In a two-Layer Program, used in conjunction with Parameter 228 (Balance Sensitivity), it enables you to perform equal-power crossfades between Layers using any MIDI Control Source.

A Value of Off disables Balance Control.

A Value of On will attenuate (reduce) the Layer's volume by 18 dB.

Assign a Control Source (such as the Mod Wheel) to enable a MIDI control to attenuate the Layer. Figure 8-1 illustrates the effect on Layer volume of Control Sources assigned to Parameter 227.

The solid curve represents the effects of a Control Source when Parameter 228 (Balance Sensitivity) is set at Norm. With the Control Source at minimum, the Layer is not affected. At midpoint, the Layer is attenuated by 3 dB. With the Control Source at maximum, the Layer is attenuated by 18 dB.

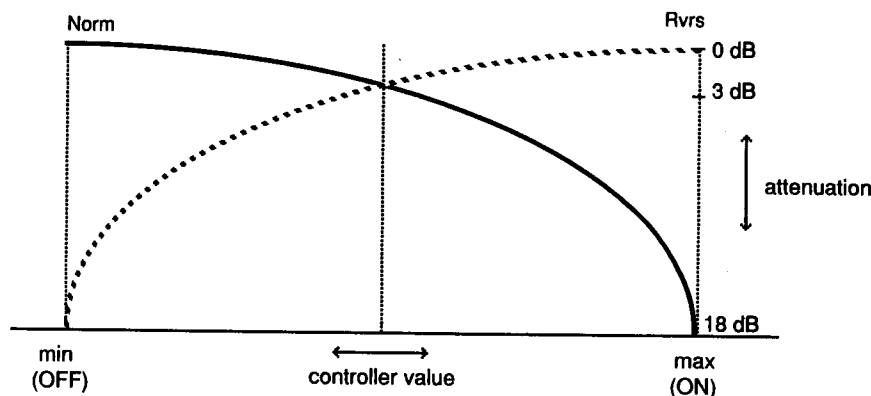

Figure 8-1 Balance Control Response

The dotted curve represents the effects of reversed (Rvrs) Balance Sensitivity.

If you create a two-Layer Program with different Soundfiles on each Layer, you can use Balance Control to achieve an equal-power crossfade between the two. Assign the same Control Source to each Layer using Parameter 227, then select Parameter 228 and set one Layer to Norm and the other to Rvrs. The resulting crossfade will have a maximum separation of 18 dB.

228 Balance Sensitivity
 • Norm/Rvrs

Enables you to determine the polarity of the Balance Control in response to the control assigned to affect Balance (see Parameter 227 and Figure 8-1).

229 Alternate Attack
 • Control Source List

Allows you to choose between the normal attack of the Layer's Soundfile and an alternate, later point in the Soundfile.

Many of the K1200's Soundfiles begin with a "keyclick" in the attack. The alternate attack eliminates (or greatly reduces) the click of the attack on these sounds. The alternate attack for acoustic instrument timbres corresponds to the beginning of the loop section.

With a Value of Off, the normal attack for the current Layer's Soundfile will always be used.

A Value of On causes the Layer to use its alternate attack point at all times.

Select from the Control Source List to alternate between attack

Section VIII

segments using a MIDI Control Source. If the assigned Source is below its midpoint at the start of the note, the normal attack will be used. If it is above midpoint, the alternate attack will be used.

230 Stereo Pan
• L to R
Auto
Inv Auto

Enables you to define Layer Pan settings between the Left and Right Audio Outputs.

Use either VALUE button to change the Pan location. The display will show an asterisk (*) which indicates the position of the current Layer with respect to the Audio Outputs. There are nine Pan positions, including the extremes.

If you select a Value which exceeds either extreme, the display will change to show two additional Values — Auto Pan and Inv Auto Pan. These provide Pan settings which are a function of MIDI Note number.

Select Auto Pan, and the lowest notes of the Layer will be directed to the Left Audio Output. The highest notes will go to the Right Audio Output, with a progressive pan from left to right for each successively higher note.

Inv Auto Pan provides the reverse of Auto Pan — low notes

to the right, and high to the left. (This corresponds, for example, to the seating arrangement of orchestral string sections as heard from the audience perspective.)

231 Touch Sensitivity
• On
Off

Determines how the current Layer will respond to velocity data from the keyboard.

Select a Value of On, and higher MIDI Velocity numbers (corresponding to harder keystrokes) will cause corresponding increases in the loudness of notes.

With a Value of Off, the Layer will have no touch sensitivity. If the Soundfile has multiple timbre levels (as does Grand Piano, for example), the timbre corresponding to the maximum keystroke velocity will always be used. Each note will respond as if it had received a maximum-velocity signal from the keyboard.

232 Velocity Trigger 1
• ppp to fff

Velocity Trigger 1 is a Logical Control Source. Assigning a Velocity Trigger enables you to initiate an effect depending on the MIDI Velocity number sent by the keyboard. This Parameter allows you to set the dy-

namic level at which the Trigger is activated.

The K1200 checks each Note On signal from the keyboard and compares its MIDI velocity number to the Value that you set for Parameter 232. If the MIDI velocity exceeds the threshold Value of the Parameter, Velocity Trigger 1 switches On (it is normally Off).

The Values for Parameter 232 are the same 8 dynamic levels used to set Velocity Maps. The actual MIDI Velocity required to reach the threshold depends, therefore, on the Velocity Map that you have selected with Master Parameter 005 or 041.

The action of Velocity Trigger 1 also depends on the setting of Parameter 233 (Velocity Sensitivity 1).

233 Velocity Trigger 1 Sense
• Norm
Rvrs

Defines the response of Velocity Trigger 1 to Velocity signals.

With a Value of Norm, MIDI Velocity signals exceeding the Value of Parameter 232 will switch the Trigger On. Values below that will switch it Off.

A Value of Rvrs reverses the sensitivity of Velocity Trigger 1: the Trigger will normally be On, and will switch Off when the threshold is reached.

234 Velocity Trigger 2
235 Velocity Trigger 2 Sense

Velocity Trigger 2 functions in the same way as Velocity Trigger 1 (see above).

236 Layer Enable Sense
(EnableSense in display)

- Norm
- Rvrs

This Parameter works in conjunction with Parameter 217 Layer Enable, which gives you several options for turning Layers on and off. You may toggle the Value of EnableSense from Normal to Reversed by pressing either [VALUE] button. When you reverse EnableSense, then whatever control source you have assigned to enable the current Layer will be reversed in its function. Here's an example.

You want to switch quickly back and forth between two different synth sounds during a solo. Simply create a two-Layer Program using the sounds you want, then set both Layers to be enabled by the Sostenuato Pedal (or any controller you choose). Make sure that one of the Layers has EnableSense set to Norm, and the other to Rvrs. Then use the Sostenuato Pedal to alternate between the two sounds.

237 Opaque Layer

- Off
- On

This Parameter is very effective for creating complex Programs which give you numerous ways to activate and deactivate Layers. Setting the Value of this Parameter to On (with either [VALUE] button) makes the currently selected Layer "opaque," screening all higher-numbered Layers in the Program as long as the opaque Layer is playing.

For example, consider a Program which is a two-layer combination of Grand Piano and Stereo Piano. Layer 1, the Stereo Piano, is an opaque Layer, and covers a range from C3 to G6. Layer 2, the Grand Piano, covers the entire keyboard. When you play outside the range of the Stereo Piano, you will hear only the Grand Piano. When you play in the C3 to G6 range, you will hear only the Stereo Piano, since the Grand Piano Layer is eclipsed by the opaque Stereo Piano Layer.

Now set Layer 1's Layer Enable Parameter to Sostenuato (with EnableSense = Norm). Now, you ordinarily will hear the Grand Piano Layer throughout its entire range. Depress the Sostenuato pedal, and the Stereo Piano will replace the Grand

Piano between C3 and G6 as long as the Sostenuato pedal is down.

238 Hold Thru 1st Amp Env
Attack Segment
(HoldThruAttk in display)

- Off
- On

Normally, when you release the trigger for a given note, the note immediately goes into its release, which is often instantaneous. Setting this Parameter to On (by pressing either [VALUE] button) will cause all notes in the current Layer to sustain through the first attack segment of their Amplitude Envelope (natural or user-programmed) regardless of when the note trigger is released.

239 Hold Until Sustain Section
of Amp Env
(HoldTillSust in display)

- Off
- On

This is similar to HoldThruAttk, except that with this Parameter set to On, all notes in the current Layer will sustain through the *last* segment of the attack section of the Amplitude Envelope. Note that this does not include the Attack End segment; you will not hear any sustain or loop that you may have programmed into your Amplitude Envelope.

Section IX

MODULAR EFFECTS EDITING

9.1 Introduction

Modular Effects represent the most advanced Program editing level of the 1000 Series.

When you select Modular Effects using Layer Parameter 216, you gain access to a digital emulation of a traditional modular synthesizer comprising a number of building-block elements, or "Modules." By navigating among the Modular Effects Menus and selecting Values for specific Parameters, you can freely "patch" together virtually any logical combination of Modules to obtain a very broad range of effects.

Just as in analog synthesizers, the K1200's Modules are grouped in two basic classes — signal generators and signal modifiers. Signal generators originate waveforms, while signal modifiers accept waveforms at their signal inputs and act upon them in specific ways. Both classes of Modules may be controlled externally by MIDI controllers or other Modules.

Within these two classes, Modules are further distinguished as belonging to either of two separate groups — the audio group and the control group.

The audio group handles the sound signal that is actually heard at the K1200's Audio Outputs. Signals in the audio group originate from the K1200's Soundfile list.

The control group handles signals that are meant not to be heard by themselves, but to affect the actions of other Modules. Control group signals lie in the frequency range between DC and 50 Hz. They include both MIDI controller signals and output signals from control group Modules.

9.1.1 Conceptual Model

Figure 9-1 shows how the K1200's digitally-emulated modular synthesizer might look, were it to be implemented as a traditional analog instrument.

Local Modules — Each Layer of every Program accesses its own set of Local Modules which can provide independent and individual control over each note played in the Layer. Patches among Local Modules are unique to the Layer, and each Layer can have an entirely different Local Module configuration.

The audio group within each Layer begins with the originating Soundfile. Optionally, you can access two envelopes (Amplitude Envelope and Envelope 2), an amplitude modulator (Amplitude Control), and a frequency modulator (Pitch Control).

The remainder of the Local Modules in Figure 9-1 are all in the control group. They can be used to generate and process

control signals for routing to the control inputs of Modules in either group within the Layer.

Global Modules — Each Program also may access a set of four Global Modules, all of which are control signal generators. These Modules send the same control signal to every Layer at once, but may be patched independently within each Layer.

9.1.2 Defining & Deleting Modules

To maximize efficient use of the K1200's Program memory, most of the Effects Modules shown in Figure 9-1 do not actually "exist" for a given Layer until you *create* them.

Modules are created simply by selecting any Parameter within their Menus (other than the Menu heading) using either PARAMETER button. Once created, a Module can be *defined* by assigning Values to its Parameters. If a Module has never been defined, or if an existing one has been deleted, it is said to be "undefined."

A Module may be deleted by selecting the first Parameter in its Menu (Delete Module) and answering YES to the prompt. After deleting the Module, the K1200 will return to the Menu heading, where you will see "(undefined)" in the lower line of the display.

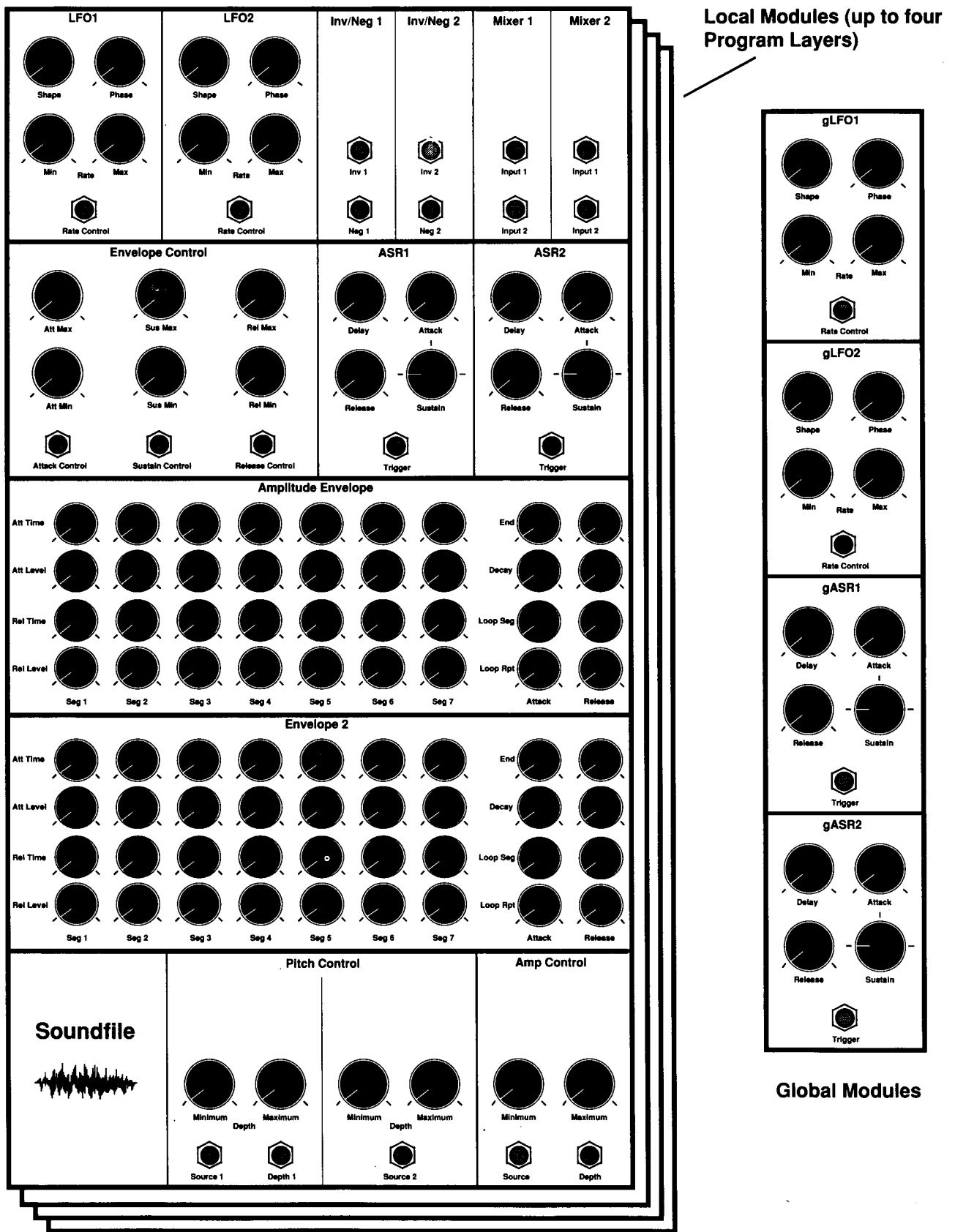

Figure 9-1 Conceptual Model of 1200 Series Modular Effects (Each Program)

Section IX

9.2 Low Frequency Oscillators

Note —In order to keep the memory of your K1200 as free as possible, it is a good idea to delete any Modules that you are not using before saving a Program.

9.1.3 Patching Modules

The outputs of all of the control group Modules in Figure 9-1 can be visualized as being “hard-wired” to the Control Source List.

Where a control input jack is shown in the Figure, it indicates that you may input any logical selection from the Control Source List. All such patching is performed by moving among Parameters in the Menus and changing Values. Where a particular Module’s output is not available for a given Parameter, it will not appear in the Control Source List as a possible Value for that Parameter.

The audio group Modules, by contrast, are “hard-wired” as they are created and defined. If no audio signal modifiers are selected, the Soundfile signal passes directly to the Program level. When you create an audio group module (such as Amplitude Envelope), it is automatically inserted in the audio chain.

The Low Frequency Oscillators (LFOs) are control signal generators that produce low-frequency waveshapes which may be routed to various control inputs. The Outputs of the LFO Modules are normally bipolar, but can be made unipolar by selecting a waveshape preceded by a “+” (see Parameter 415, below).

Each Program may have two global LFOs, and each Layer of every Program may have two local LFOs.

9.2.1 Local Low Frequency Oscillator 1

410 LFO1

This is the Menu heading.

411 Delete LFO1

- Yes

Deletes the LFO1 Module. Press YES to begin the deletion sequence.

412 Minimum Rate

- 0.00 Hz to 50.00 Hz
- Varies depending on the Value range

Sets the lowest LFO1 frequency (or rate) for the current Layer. This Parameter also determines the rate of LFO1 when the Rate Control (Parameter 414) is at its minimum Value, or is set to a Value of Off.

413 Maximum Rate

- 0.00 Hz to 50.00 Hz
- Varies depending on the Value range

Sets the highest LFO1 frequency (or rate) for the current Layer. This Parameter also determines the rate of LFO1 when the Rate Control (Parameter 414) is at its maximum Value, or is set to a Value of On.

414 Rate Control

- Control Source List

This Parameter selects the rate control input for LFO1.

With a Value of Off, LFO1 will generate a Waveshape at a rate set by the Minimum Rate Parameter (see above). If On is chosen, LFO1 will generate a Waveshape at a rate set by the Maximum Rate Parameter.

You may also select an On/Off switching device, such as “Sustain” (the Sustain Pedal), to feed this input. Any switch will provide the Maximum Rate when the switch is On, and the Minimum Rate when it is Off.

Other Values can select a device that is capable of continuous control (such as Breath, Pressure, or Mod Wheel). Such a device will provide continuously variable control of LFO1’s rate within the boundaries set by the Minimum Rate and Maximum Rate Parameters.

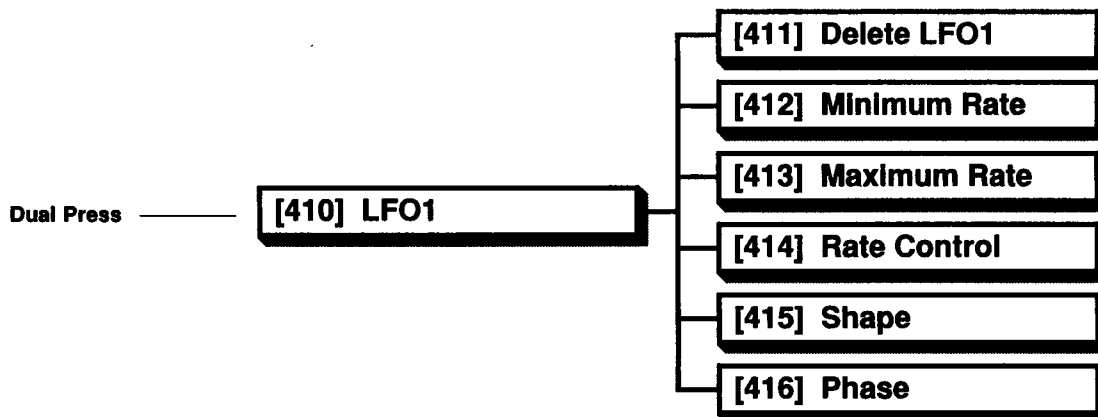

415 Shape

- Sine
- Cosine
- +Sine
- +Cosine
- Rise Saw
- Fall Saw
- +Rise Saw
- +Fall Saw
- Square
- +Square
- Triangle
- +Triangle
- Dbl Pulse
- Circle
- Stair
- +Stair
- Asym Tri 1
- Asym Tri 2
- White Nz
- Red Nz
- Green Nz
- Blue Nz

Selects the waveshape for LFO1. Waveshapes whose names are preceded by a "+" are unipolar and positive-going; all others are bipolar.

416 Phase

- 0°
- 90°
- 180°
- 270°

Determines the initial phase (starting point) for LFO1's output waveform.

Considering a sine wave for example, 0° is the beginning of the wave (amplitude 0, becoming positive); 90° is maximum positive amplitude; 180° is 0 amplitude, becoming negative; and 270° is maximum negative amplitude.

9.2.2 Local LFO2

420 to 426 LFO2

Parameters 420 through 426 control the the Local LFO2 Module. The programming procedures for LFO2 are identical to those for LFO1, so the descriptions of the Parameters for LFO1 apply to LFO2, as well.

9.2.3 Global LFOs

- 430 to 436 gLFO1**
- 440 to 446 gLFO2**

Parameters 430 through 436 and 440 through 446 control the operation of the Global LFO Modules. The programming procedures for the global LFO Modules are identical to those for LFO1.

Section IX

9.3 Attack Sustain Release Envelope Generators

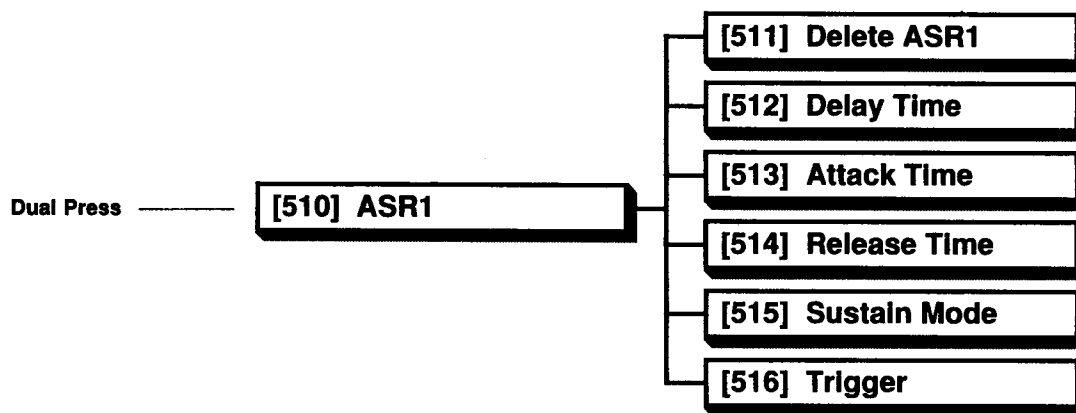

9.3.1 Local ASR1

ASR1 generates, when triggered, a unipolar control signal with three segments that constitute an envelope: attack, sustain, and release.

ASR1 may be assigned from the Control Source List to any control input within the current Layer. The ASR envelope is often used to modify the amount or rate of another control signal.

510 ASR1

This is the Menu heading.

511 Delete ASR1

- Yes

Deletes the ASR1 Module from the current Layer. Answer YES to initiate the deletion sequence.

512 Delay Time

- 0.00 s to 10.00 s
- Varies depending on the Value range

Determines the amount of time, in seconds, before ASR1 begins generating its envelope after it has been triggered.

Select a Value of 0.00 s, and ASR1 will begin its attack segment immediately when it receives a trigger from any source (typically the keyboard).

For Values other than 0.00 s, there will be a time delay equal to the Value.

513 Attack Time

- 0.00 s to 10.00 s
- Varies depending on the Value range

Determines the length of the attack segment of the current ASR1. The term "attack time" refers to the time required for the attack segment to progress to its maximum, before beginning its sustain or release segment.

514 Release Time

- 0.00 s to 10.00 s
- Varies depending on the Value range

Determines the length of the release segment for ASR1. The term "release time" refers to the time required for the release segment (at the end of the sustain or attack segment) to progress to its minimum, which marks the end of the envelope.

515 Sustain Mode

- Norm
- Hold
- Rept

Enables you to select among three modes for the sustain segment of ASR1. Each Mode creates a significantly different effect.

Normal Mode causes ASR1 to generate a single two-segment envelope using only the attack and release segments. Even if the trigger is held on indefinitely, ASR1 will progress through its attack segment, then immediately proceed to its release segment, which will continue to the end of the envelope.

Hold Mode causes ASR1 to generate a single three-segment envelope. When the attack segment reaches its maximum, the maximum level will be sustained as long as the trigger for ASR1 is on. When the trigger is shut off, the release segment will begin and progress through to the end of the envelope.

Repeat Mode causes ASR1 to generate repetitive two-segment

envelopes. When the end of a release segment is reached, the attack segment will begin again, and the envelope will repeat as long as the trigger is on. Once the trigger is shut off, the envelope will continue to the end of the last release segment.

516 Trigger

- Control Source List

Selects a Control Source for triggering ASR1.

With a Value of On, ASR1 will begin generating its envelope when a MIDI Note On is received, then progress according to the Mode that is set with Parameter 515. With the Value set to Off, the ASR will be disabled.

If the selected Control Source is a switch such as the Sustain pedal, ASR1 will be triggered when the switch goes from Off to On, and remains on as long as the switch remains on.

Some Values select Control Sources that are capable of producing continuously varying Control signals (the Modulation Wheel, for example). If you select one of these continuous Control Sources, the Trigger for ASR1 will switch on when the signal from the Control Source exceeds its midpoint. (This threshold is set by the K1200's system software, and is not programmable.)

9.3.2 Local ASR2

520 to 526 ASR2

The Parameters for ASR2 are identical to those for ASR1.

9.3.3 Global ASRs

530 to 536 gASR1 540 to 546 gASR2

gASR1 and gASR2 are global envelopes, so they affect all Layers of the Program to which they are assigned.

Each Program can have two global ASRs. Each Global ASR may be triggered by a different Control Source, and may be assigned to control different Modules. A global ASR will generate an envelope only if its Program is assigned to a MIDI channel.

The programming of Global ASRs is identical to that of the local ASRs.

Note — "On" may not be a useful Value for gASRs, because with this Value, they would begin their envelopes as soon as their Program is assigned to a MIDI channel.

Section IX

9.4 Local Mixers

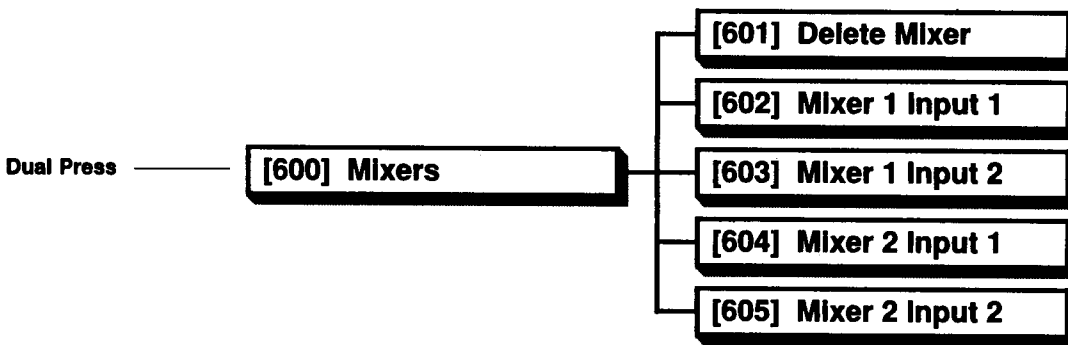

The K1200 provides two Mixers (MXR1 and MXR2), which may be separately programmed and assigned, for each Layer of a Program. These are local Modules: they affect each note in the current Layer independently.

Each Mixer has two Inputs to which you may assign any of the Layer's Control Sources. The Mixer adds together the two signals at its inputs, limits the sum to within ± 1 , and presents the sum at its output.

The Mixers' outputs are themselves Control Sources, and appear on the Control Source List, from which they may be assigned to any local Module Parameter that shows "Control Source List" as a Value. While each Mixer output has bipolar capability, it will be effectively unipolar if the mixer inputs are both unipolar control signals.

600 Mixers

This is the Menu heading.

601 Delete Mixer

• Yes

Deletes the Mixer Module for the current Layer. Pressing YES will initiate the deletion sequence.

602 Mixer 1 Input 1

603 Mixer 1 Input 2

604 Mixer 2 Input 1

605 Mixer 2 Input 2

• Control Source List

Parameters 602 to 605 allow you to assign Control Sources to the Inputs of each of the Mixers in the current Layer.

9.5 Local Inverters / Negators

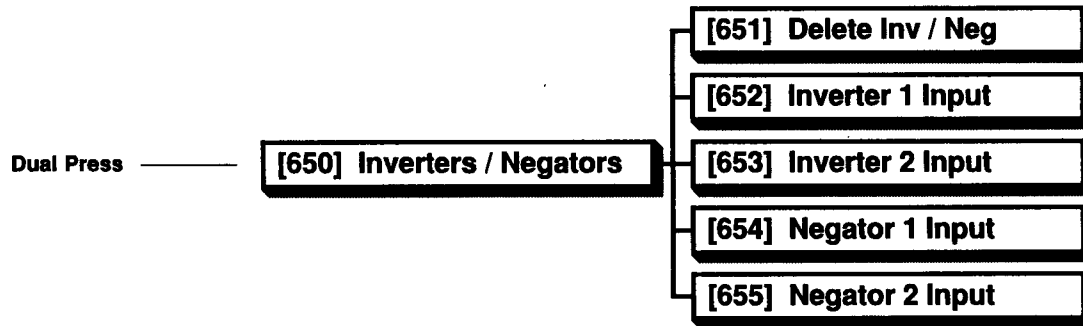

The Inverters/Negators Module is a multiple-function Local Module: it provides you with two Inverters and two Negators, each of which operates independently, for each Layer in a Program. The Inverters and Negators are control signal processors, and their outputs are available as Control Sources that can be assigned to any local Module Parameter showing "Control Source List" for its Value.

The effect of an Inverter is shown in Figure 9-2. The Inverter reverses the *amplitude* of the input signal, leaving the *sign* unchanged. Negators are

the converse of Inverters: Negators reverse the *sign* of the waveshape, while preserving its amplitude (see Figure 9-3).

Generally, Inverters are used with unipolar signals, while Negators are used with bipolar signals.

650 Inverters/Negators

This is the Menu heading.

651 Delete Inverters/Negators • Yes

Enables you to delete the Inverter/Negator Module from

the current Layer. Press YES to initiate the deletion sequence.

652 Inverter 1 Input 653 Inverter 2 Input • Control Source List

Parameters 652 and 653 represent the Inputs of Inverters 1 and 2, respectively.

654 Negator 1 Input 655 Negator 2 Input • Control Source List

Parameters 654 and 655 represent the Inputs of Negators 1 and 2, respectively.

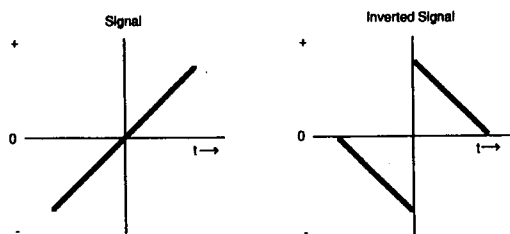

Figure 9-2 Effect of Inverter

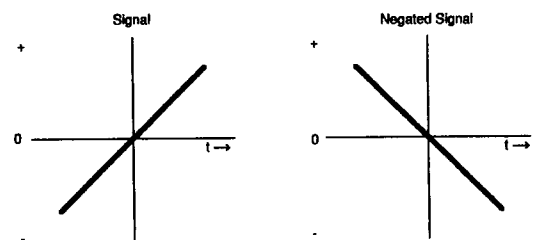

Figure 9-3 Effect of Negator

Section IX

9.6 Amplitude Envelopes

Many of the K1200's Soundfiles use Amplitude Envelopes that are created as part of the process of digitizing the sounds.

When you select a Parameter from the Amplitude Envelope Menu, you replace the preprogrammed (or "natural") envelope with a default user-defined envelope having one attack and one release segment. This is your "blank palette" for the construction of your own Amplitude Envelope. (The original envelope is stored in ROM, and will be restored if you delete the user-defined envelope using Parameter 701 or exit Edit Mode without saving your changes.)

Amplitude Envelopes are unipolar, and may contain up to seven attack and seven release segments. Each segment of the Amplitude Envelope is defined by specifying a time and level. The first attack segment always starts at zero amplitude, and the final release segment always ends at zero amplitude.

Note — The Local Amplitude Envelope and Envelope Control Modules are available at the Compiled Effects Editing Level, as well. The Envelope Control Module is described in Section 9.6.3.

9.6.1 Local Amplitude Envelope

700 Amplitude Envelope

This is the Menu heading.

701 Delete Amplitude Envelope

• Yes

Enables you to delete the Amplitude Envelope Module from the current Layer. Use this Parameter to restore the preprogrammed Amplitude Envelope (if any) to the current Layer.

Pressing YES will initiate the deletion sequence.

702 Add Attack Segment

• Yes

Enables you to add an attack segment to the Amplitude Envelope in the current Layer. Each Layer's Amplitude Envelope may contain as many as seven attack segments.

When you add or delete Envelope segments, any notes that your K1200 is currently playing will be silenced. *You will not be able to play the K1200 while adding or deleting Envelope segments.*

Press YES to start the insertion sequence. The display will

prompt you. The lower line will show the index numbers of the envelope's existing segments, and a cursor (single-character underscoring) will show to the right of the highest number.

If you press NO here, you will return to the "Add Attack Seg?" display without adding a segment. (This is a convenient way to check the number of segments in an envelope without changing the envelope.) Press YES to add an envelope segment at the position of the cursor. All higher-numbered segments will be renumbered.

You may change the position of the cursor before pressing YES to select an insertion point between two existing segments. Use the PARAMETER buttons to move the cursor left or right. Choose a cursor location, press YES, and the new segment will appear at the cursor location.

If you attempt to add a segment to an envelope already containing seven segments, the display will alert you and then will return to the "Add Attack Seg?" display.

NOTE — For each attack segment that your Amplitude Envelope contains, a pair of Parameters will be generated (see Parameters 704 through 717, below). These Parameters enable you to set the time and level for each of the attack segments in the envelope.

Dual Press

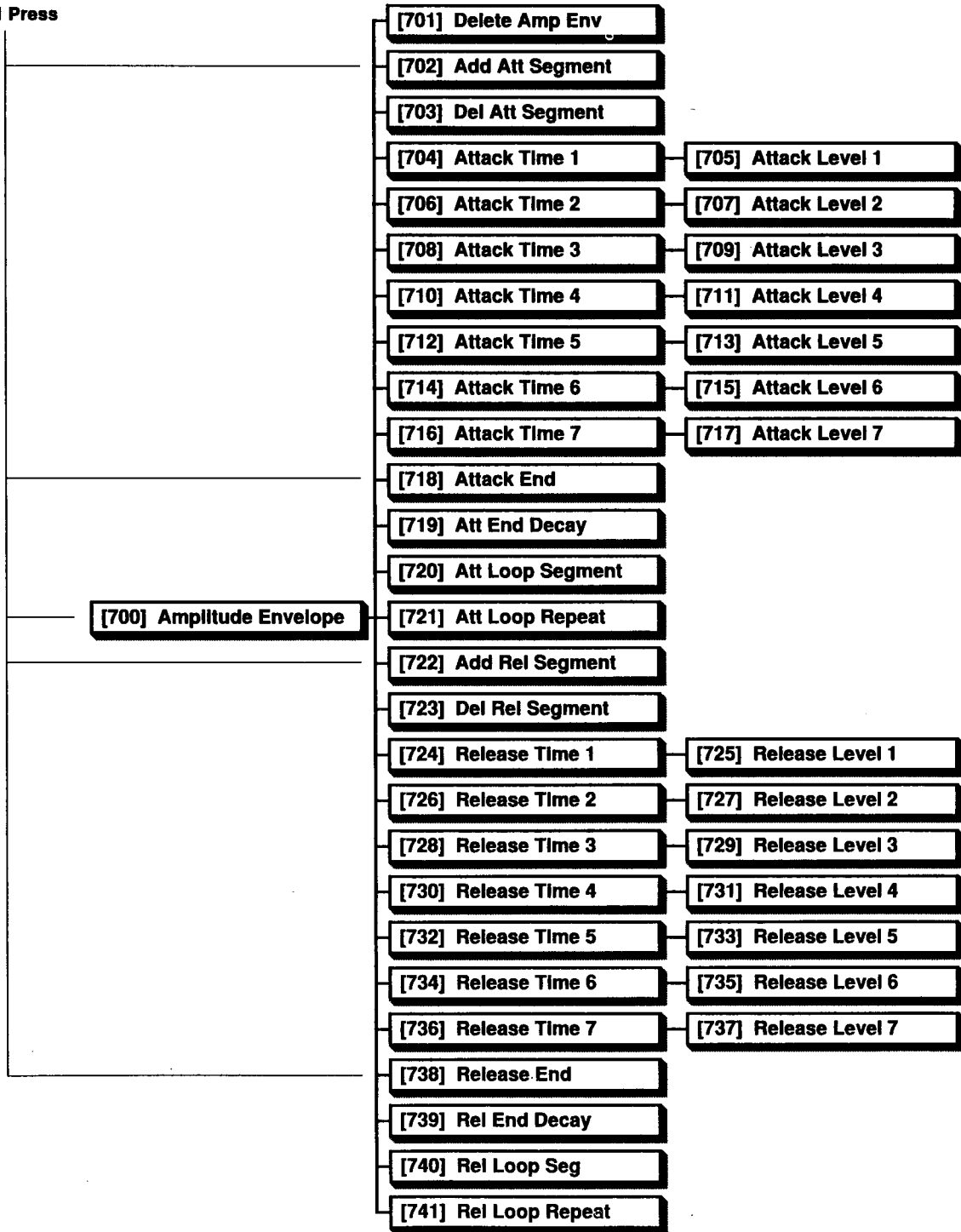

Section IX

The programming procedure for each of these pairs of Parameters is almost identical. The one exception is that the Value of Attack segment 1 defaults to 0.00s, and will remain so if you do not change it. The Values of all other Attack segments default to 0.01s, however; only the first Attack segment may have a Value of 0.00s.

The initial level for each Attack segment corresponds to the final level of the segment preceding it. In the case of Attack segment 1, this is always 0; for other segments, it will be equal to the Value that you set for the previous segment.

703 Delete Attack Segment

- Yes

Enables you to delete an attack segment of the Amplitude Envelope for the current Layer.

Pressing YES initiates the deletion sequence. The procedure is similar to that for adding attack segments (see Parameter 702, above).

Note — Every envelope must have at least one attack segment. If you attempt to delete an attack segment from an envelope containing only one attack segment, the display will alert you, and then will return to the "Delete Attack Seg?" display without deleting the segment.

704 Attack Time 1

- 0.00 s to 10.00 s
- Varies depending on the Value range

Determines the time in seconds required for Attack segment 1 to progress from zero amplitude to its specified level. (The level for Attack segment 1 is set using Parameter 705.) The default Value for Attack segment 1 is 0.00 s.

705 Attack Level 1

- 0% to 100%
- +20%

Sets the level to which Attack Segment 1 increases during the time specified by Parameter 704.

- 706 Attack Time 2
- 707 Attack Level 2
- 708 Attack Time 3
- 709 Attack Level 3
- 710 Attack Time 4
- 711 Attack Level 4
- 712 Attack Time 5
- 713 Attack Level 5
- 714 Attack Time 6
- 715 Attack Level 6
- 716 Attack Time 7
- 717 Attack Level 7

See the descriptions for Parameters 704 and 705, above.

718 Attack End

- Sustain
- Decay
- LoopFwd
- LoopBiD

Defines a special attack segment which begins at the end of the highest-numbered regular attack segment. If you have defined only one attack segment, the Attack End segment will begin as soon as Attack Segment 1 has finished.

The four possible Values have different programming requirements. Parameters 719 through 721 relate only to certain Attack End Values, and will not appear in the display unless the relevant Attack End Value is selected with Parameter 718. If your Amplitude Envelope contains just one attack segment, you will have a choice between only two Values — Sustain and Decay.

Sustain will maintain the ending level of the final regular attack segment as long as the note trigger remains on. The first Release segment will not begin until the note trigger is released. Parameters 719 through 721 will not appear when you have selected Sustain.

Loop Forward will cause part or all of the Attack segment to repeat. You may program which attack segments will be

included in the loop by using Parameter 720, and how many times the loop will repeat before initiating the release segment by using Parameter 721.

When Loop Forward is selected, the Amplitude Envelope will progress normally through all of its programmed attack segments. Once it reaches the Attack End segment, the envelope will jump to the end of the segment that you specify with Parameter 720. It will ramp to the final level of the specified loop segment in a period of time equal to the Time setting for that segment. The Envelope then will again progress through to the Attack End segment, repeating the process as many times as you specify with Parameter 721.

Loop Bidirectional operates like Loop Forward, except that the Amplitude Envelope is played alternately backward and forward.

When Loop Bidirectional is selected, the Amplitude Envelope will progress normally through its programmed Attack segments. Once it reaches the Attack End segment, instead of jumping back to the beginning of the specified segment, the Envelope will reverse its direction and move back to the end of the specified loop segment.

NOTE — The Attack and Release sections of an Envelope must have more than one segment before you will be able to select either of the looping options.

Decay will cause the Attack End segment to decay to zero amplitude within the time specified by Parameter 719 (described below). If the note trigger is released before the Attack End segment has finished, the release segment will begin at the current amplitude.

719 Attack End Decay
• 0.01 s to 10.00 s
◦ Varies depending on the Value range

When the Value of Parameter 718 is set to Decay, this Parameter will be enabled. It allows you to determine the amount of time, in seconds, required for the Attack End segment to decay to zero from its specified Value.

720 Attack Loop Segment
• 1 to 7

Enables you to specify the Attack segment to which the Amplitude Envelope returns when you have selected Loop Forward or Loop Bidirectional.

Note — You cannot assign a Value which is higher than the number of Attack segments in your Amplitude Envelope.

721 Attack Loop Repeat

- Inf
- 1 to 255
- +10

Determines the number of times the Amplitude Envelope will repeat the loop you have specified with Parameters 718 and 720. If you select a Value of Inf (infinite), the loop will repeat without interruption as long as the note trigger is held on; once the note trigger is released, the Envelope will proceed through the Release segment(s).

722 Add Release Segment
• Yes

Enables you to add up to seven Release segments to the current Amplitude Envelope. As with Attack segments, every Release segment that you add generates a pair of Parameters relating to the Time and Level for that segment.

Answer YES to add a Release segment. If there are no Release segments in the current Amplitude Envelope, the display will briefly notify you, and then will return to the "AddRelSeg?" display.

With one or more Release segment(s) in the Envelope, pressing YES generates a display with the existing Release segments shown in the lower line of the display, highest-numbered segment on the right.

Section IX

A cursor will appear immediately to the right of the highest numeral. Use the PARAMETER buttons to move the cursor left and right.

Pressing NO here will return you to the "AddRelSeg?" display without adding the segment.

If you press YES instead, the K1200 will add another segment, and the "AddRelSeg?" display will reappear. If you attempt to add a segment to an Envelope already containing the maximum of seven Release segments, the display will notify you and then the "AddRelSeg?" display will reappear.

723 Delete Release Segment

• Yes

Enables you to delete any Release segment in the current Amplitude Envelope.

Press YES to begin the deletion sequence. The procedure is similar to that for adding Release segments (Parameter 722, above).

If the Envelope contains only one Release segment and you attempt to delete it, the display will inform you, and quickly return to the "Del Release Seg?" display.

724 Release Time 1

- 0.01 s to 10.00 s
- Varies depending on the Value range

This Parameter determines the amount of time, in seconds, required for Release Segment 1 to decay from its initial level to the level that you specify with Parameter 725.

Note — Each Release segment has a minimum time Value of 0.01 seconds. To achieve an instantaneous release, you must delete all Release segments, set Parameter 738 (Release End) to Decay, and set Parameter 739 (Release End Decay) to a Value of 0 s.

725 Release Level 1

- 0% to 100%
- +20%

Determines the decrease in amplitude of the current Release segment.

The first Release segment begins at an initial level of 100% and decreases to a percentage (set with this Parameter) of the initial level. The initial level is equal to the final level of the segment preceding it (or, in the case of the first Release segment, the level of the Attack End segment when the note trigger is released).

726 Release Time 2

- 727 Release Level 2
- 728 Release Time 3
- 729 Release Level 3
- 730 Release Time 4
- 731 Release Level 4
- 732 Release Time 5
- 733 Release Level 5
- 734 Release Time 6
- 735 Release Level 6
- 736 Release Time 7
- 737 Release Level 7

See the descriptions for Parameters 724 and 725, above.

738 Release End

- Decay
- LoopFwd
- LoopBiD

Similar to Parameter 718 (Attack End), this parameter defines a special Envelope segment that begins at the end of the highest-numbered Release segment. If you have added no Release segments, the Release End segment begins when the note trigger is released.

The three possible Values for the Release End segment operate in the same fashion as the corresponding three types of Attack End segments (see Parameter 718). (The Value of Sustain is not available for the Release segment.)

739 Release End Decay

- 0.00 s to 10.00 s
- Varies depending on the Value range

Identical in function to Parameter 719 (Attack End Decay).

740 Release Loop Segment

- 1 to 7

Identical in function to Parameter 720 (Attack Loop Segment).

741 Release Loop Repeat

- Inf
- 1 to 255
- +10

Identical in function to Parameter 721 (Attack Loop Repeat).

9.6.2 Envelope 2

800 to 841 Envelope 2

All of the Parameters for the programming of Envelope 2 are identical to those for the Amplitude Envelope (Parameters 700 through 741).

The sole difference between the Amplitude Envelope and Envelope 2 is that the Amplitude Envelope is unipolar (positive amplitudes only), while Envelope 2 is bipolar (both positive and negative amplitudes can be generated).

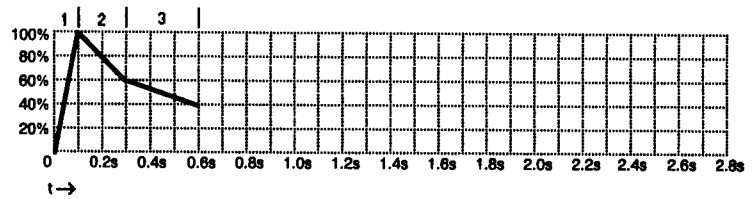

3-segment Attack section of Envelope
Segment 1: Time = 0.1s Level = 100%
Segment 2: Time = 0.2s Level = 60%
Segment 3: Time = 0.3s Level = 40%

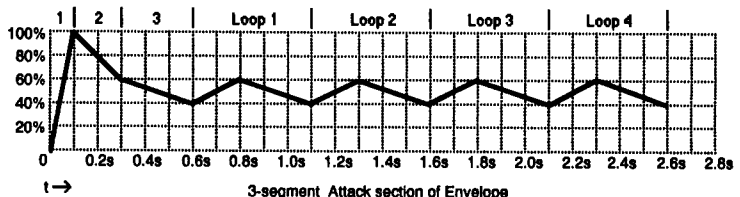

3-segment Attack section of Envelope
Attack End - Loop Fwd Loop Segment - 2 Loop Repeat - 4

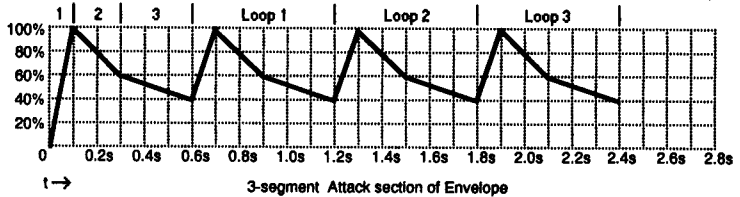

3-segment Attack section of Envelope
Attack End - Loop Fwd Loop Segment - 1 Loop Repeat - 3

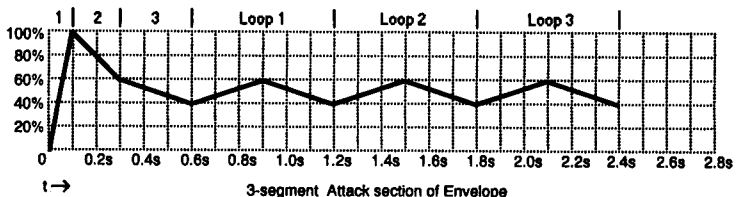

3-segment Attack section of Envelope
Attack End - Loop BiD Loop Segment - 2 Loop Repeat - 3

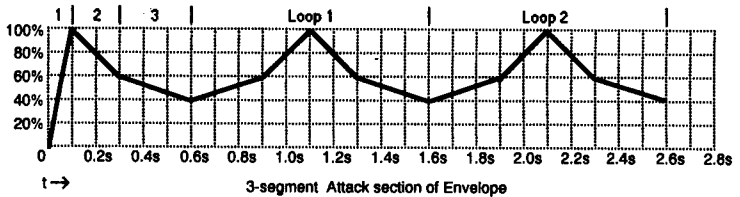

3-segment Attack section of Envelope
Attack End - Loop BiD Loop Segment - 1 Loop Repeat - 2

Figure 9-4 Amplitude Envelope Programming Examples

Section IX

Dual Press

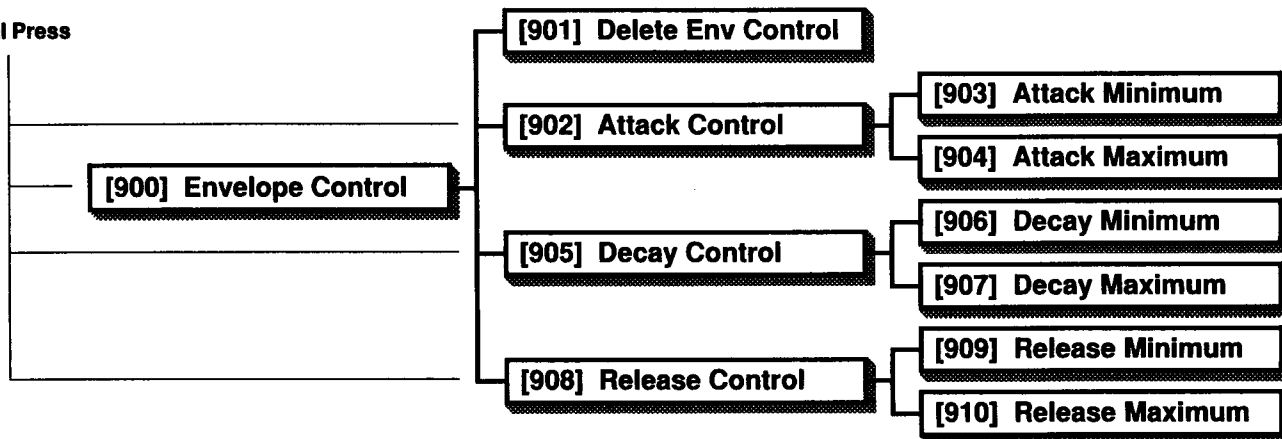

9.6.3 Envelope Control

The Envelope Control Module allows you to assign MIDI Control sources to multiply the specifications for the Amplitude Envelope and Envelope 2 by a factor of 0.1 to 10.0. This gives you real-time control over the specifications that you set for these Envelopes, affording a greater degree of performance versatility.

Note — An Envelope must be defined in order to gain access to Parameters 902 through 904, which affect the Envelope's attack. You do not have to define an Envelope of your own to control the Decay and Release sections of the current Layer's preprogrammed envelope, however.

900 Envelope Control

This is the Menu heading.

901 Delete Envelope Control

- YES

Deletes all specifications for the Envelope Control Module. Pressing YES will initiate the deletion sequence.

902 Attack Control

- Control Source List

Enables you to determine which Control Source may be used to temporarily modify the Attack times of both of the Envelopes. The amount of modification is defined by Parameters 903 and 904.

903 Attack Minimum

- x 0.100 to 10.000
- Increase by factor of 10

When the assigned Control Source (Parameter 902) sends its minimum Value, the Attack times of all the Attack segments in both Envelopes will be multiplied by the Value of this Parameter. (For example, if the Value is 0.100, the Attack times will be 1/10th their normally programmed Value.)

904 Attack Maximum

- x 0.100 to 10.000
- Increase by factor of 10

When the assigned Control Source (Parameter 902) sends its maximum Value, the Attack

9.7 Pitch Control

times of all the Attack segments in both Envelopes will be multiplied by the Value of this Parameter. (The K1200 calculates the factor for Control Source Values between minimum and maximum.)

905 Decay Control

- Control Source List

Enables you to determine which Control Source may be used to temporarily modify the Decay times of both of the Envelopes.

Remember that a Decay section will exist only if you have assigned a Value of Decay to the Attack End Parameters (718 or 818) of either Envelope, or if both Envelopes are undefined and the preprogrammed envelope of the current Layer contains a Decay section.

906 Decay Minimum

- x 0.100 to 10.000
- Increase by factor of 10

This Parameter operates for Decay times in the same fashion as Parameter 903 operates for Attack times.

907 Decay Maximum

- x 0.100 to 10.000
- Increase by factor of 10

This Parameter operates for Decay times in the same fashion as Parameter 904 operates for Attack times.

908 Release Control

- Control Source List

Enables you to determine which Control Source may be used to temporarily modify the Release times of both of the Envelopes (or of the preprogrammed envelope, if both Envelopes are undefined).

909 Release Minimum

- x 0.100 to 10.000
- Increase by factor of 10

This Parameter operates for Release times in the same fashion as Parameter 903 operates for Attack times.

910 Release Maximum

- x 0.100 to 10.000
- Increase by factor of 10

This Parameter operates for Decay times in the same fashion as Parameter 904 operates for Attack times.

The Pitch Control Module enables you to define two Control Sources for pitch modulation in each Layer of a Program. (See flowchart, next page.)

Note — You do not have to define a Pitch Control Module in order to achieve Pitch Bend Effects. Pitch Bend is “hard-wired” to pitch control, and will function according to your specifications (Parameters 223 and 224) regardless of the status of the Pitch Control Module.

920 Pitch Control

This is the Menu heading.

921 Delete Pitch Control

- Yes

Deletes the Pitch Control Module from the current Layer. Pressing YES will initiate the deletion sequence.

Section IX

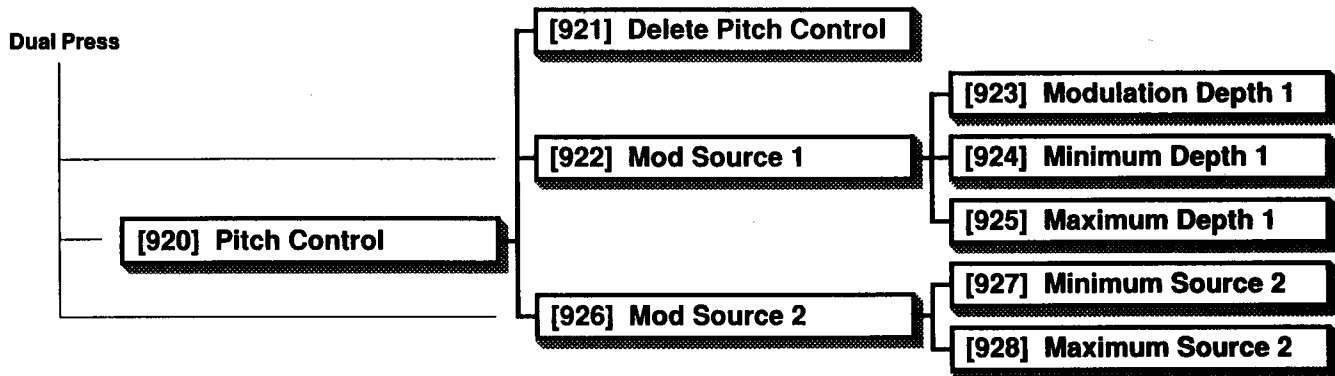

922 Modulation Source 1 • Control Source List

Determines which Control Source modifies pitch in the current Layer. Many of the K1200's preset Programs assign LFO1 as the Value for this Parameter, creating a Vibrato effect whenever LFO1 is triggered.

923 Modulation Depth 1 • Control Source List

Allows you to assign a Control Source to modify the depth of pitch modulation.

924 Minimum Depth 1 • ±100 ct • +10 ct

Use this Parameter to define a fixed depth of pitch modulation at the minimum signal sent by

Modulation Source 1. Pitch may be deflected up or down as far as one semitone (100 ct).

925 Maximum Depth 1 • ±100 ct • +10 ct

Use this Parameter to define a fixed depth of pitch modulation at the maximum signal sent by Modulation Source 1.

926 Modulation Source 2 • Control Source List

This Parameter gives you a second source of control over pitch modulation.

Unlike Modulation Source 1, Modulation Source 2 does not allow a separate Control Source to modify the depth of modulation. Minimum and maximum pitch deflection are determined

directly according to the Values you set with Parameters 927 and 928.

927 Minimum Source 2 • ±100 ct • +10 ct

Defines the amount of pitch modulation which will occur when Modulation Source 2 sends its minimum signal.

928 Maximum Source 2 • ±100 ct • +10 ct

Defines the amount of pitch modulation which will occur when Modulation Source 2 sends its maximum signal.

9.8 Amplitude Control

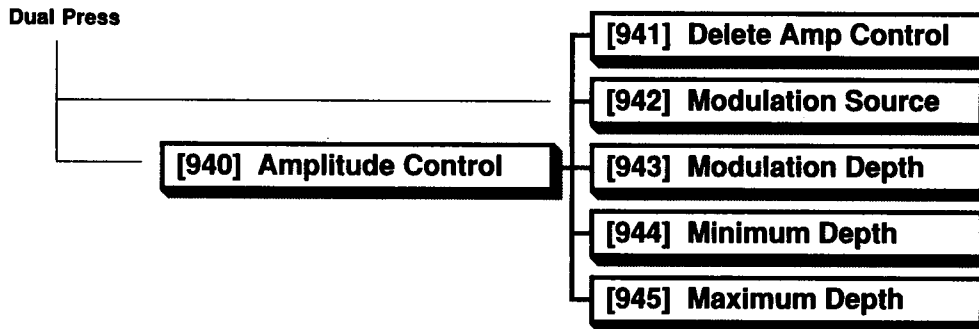

The Amplitude Control Module enables you to assign a Control Source to amplitude modulate the current Layer's output signal. The modulation is imposed in addition to—not in place of—the Amplitude Envelope (pre-programmed or user-defined).

940 Amplitude Control

This is the Menu heading.

941 Delete Amplitude Control

- Yes

Enables you to delete the Amplitude Control Module. Press YES to initiate the deletion sequence.

Note — Deleting the Amplitude Control Module will not change

the Amplitude Envelope. It merely removes the additional control over amplitude modulation that the Amplitude Control Module provides.

942 Modulation Source

- Control Source List

Enables you to assign the Control Source with which you will control Amplitude modulation.

943 Modulation Depth

- Control Source List

Enables you to assign a Control Source determining the amount (depth) of the modulation caused by the Amplitude Control Module.

944 Minimum Depth

- ± 48 dB
- +6 dB

Sets the amount (depth) of amplitude modulation when the Modulation Source (from Parameter 942) transmits its minimum signal.

945 Maximum Depth

- ± 48 dB
- +6 dB

Sets the amount (depth) of amplitude modulation when the Modulation Source (from Parameter 942) transmits its maximum signal.

Section X

PROGRAMMING TUTORIAL

10.1 Introduction

This section presents representative examples of Modular Effects editing (Compiled Effects editing is covered in the *Performance Guide*). Designed to clarify the basic concepts of 1000 Series programming, these illustrations can also serve as jumping-off points for creating your own effects.

10.1.1 Initial Setup

In preparation for making entirely new Programs, you may find it convenient to create and save a "blank palette" Program from which to work. The following procedure creates a single-Layer Program with no Effects and a default "natural" Amplitude Envelope:

- Select any K1200 Program, then press the PLAY/EDIT button to enter Edit Mode.
- Using the LAYER button, check to see whether the Program contains more than one Layer. If it does, select Parameter 205 (Delete Layer) and delete all Layers except for Layer 1.

- Select Parameter 204 (Clean Layer) and press the YES button to delete any Effects from the Layer.
- Using Parameter 216, set the Effects Edit Level to Modular (if it is not already so defined).
- Optionally, return to Parameter 206 (Soundfile) and select a default Soundfile for your palette Program.
- Using Parameters 101 (Name Program) and 102 (Save Program) in the Program Menu, name the Program "Palette" and save it to RAM.

Whenever you want to create a new Program, select the "Palette" Program from Play Mode before entering Edit Mode.

10.2 Vibrato

Vibrato is a slow, regularly-pulsing variation in the pitch of a note, used by instrumentalists to “sweeten” a tone and give it more “warmth.”

Figure 10-1 illustrates a Vibrato patch. The Pitch Control Module is used to produce programmed pitch modulation of the Soundfile by Local LFO1. To create this patch:

- Select the “Palette” Program and enter Edit Mode. Optionally, select a different Soundfile for the new patch.
- Move to the Pitch Control Menu (number 920), select
- Parameter 922 (Source 1), and set its Value to LFO1. (Dual presses of the Parameter buttons will be helpful here.)
- Select Parameter 923 (Modulation Depth 1) and set its Value to ON.
- Set Parameter 925 (Maximum Depth) to 10 ct.
- Move to the LFO1 Menu (number 410), and set Parameter 413 (Maximum Rate) to 4.00 Hz.
- Set Parameter 415 (Shape) to Sine.

- Finally, set Parameter 414 (Rate Control) to ON.

When you play your keyboard, you will hear that each note now has a slow, regular vibrato effect imposed on it.

You can begin to elaborate on this patch by assigning different Control Sources to Parameters 414 (LFO1 Rate Control) and 923 (Pitch Control Modulation Depth 1). Greater Values for Parameters 413 (LFO1 Maximum Rate) and 925 (Pitch Control Maximum Depth 1) will produce more extreme effects.

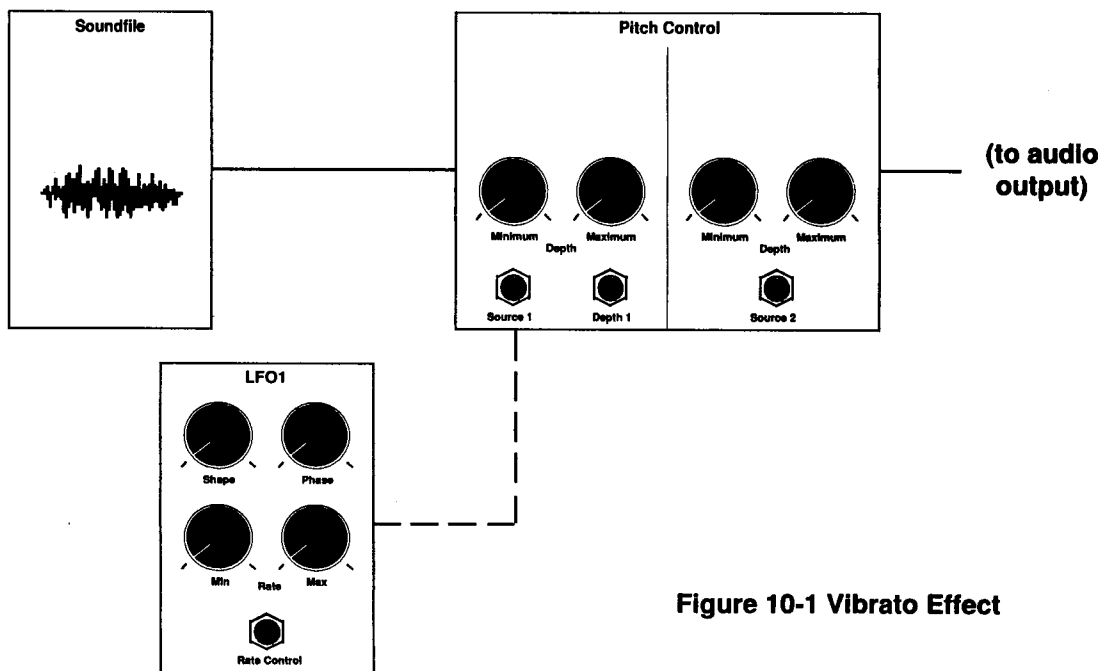

Figure 10-1 Vibrato Effect

Section X

10.3 Tremolo

Tremolo is similar to vibrato, but represents a variation in amplitude rather than pitch. Tremolo is included in most guitar amps, and the vibraphone incorporates an acoustical tremolo that is produced by a set of rotating valves inside its resonators.

Figure 10-2 illustrates a Tremolo patch (notice the similarity to Figure 10-1). The Amplitude Control Module is used to produce amplitude (loudness) modulation of the Soundfile by Global LFO1.

To create this patch:

- Select the "Palette" Program and enter Edit Mode. Optionally, select a different Soundfile for the new patch.
- Move to the Amplitude Control Menu (number 940), select Parameter 942 (Modulation Source), and set its Value to gLFO1.
- Select Parameter 943 (Modulation Depth) and set its Value to ON.
- Set Parameter 945 (Maximum Depth) to -3 dB.
- Move to the gLFO1 Menu (number 430), and set Parameter 433 (Maximum Rate) to 5.00 Hz.
- Finally, set Parameter 434 (Rate Control) to ON.

When you play your keyboard, you will hear that each note now has a tremolo effect imposed on it.

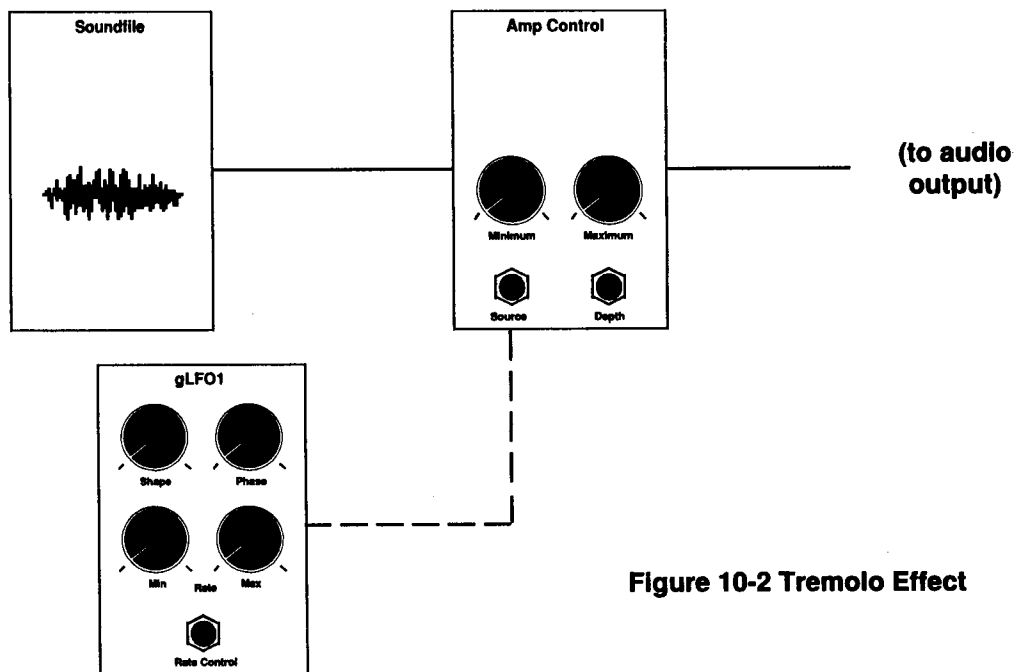

Figure 10-2 Tremolo Effect

10.4 Chorus

You can elaborate on this patch by assigning different Control Sources to Parameters 434 (gLFO1 Rate Control) and 943 (Amplitude Control Modulation Depth). Greater Values for Parameters 433 (gLFO1 Maximum Rate) and 945 (Amplitude Control Maximum Depth) will produce more extreme effects.

Note — We have used a Global LFO in this patch because tremolos on existing instruments (such as guitars and vibraphones) are global effects. That is, the tremolo effect “free-runs” all the time, and is imposed on every note in the same fashion. This differs from vibrato, which — on a clarinet, for example — is imposed by the player on each note individually.

Chorusing is a pitch-related effect which simulates the sound of a section of instruments or voices (hence the term “chorus”). In such a section, minute variations in the pitches of individual voices produce a constantly varying cloud of “beat” frequencies as voices go in and out of tune with one another.

We can approximate this sound by using two Layers, each patched for a vibrato effect as shown in Figure 10-3. To create a chorus effect:

- Select the “Palette” Program and enter Edit Mode. Optionally, select a different Soundfile for the new patch.

- Following the instructions in Section 10.2, give the current Layer a vibrato effect, but with the following changes:
 - In the Pitch Control Menu, set Parameter 924 (Minimum Depth) to -2 ct and Parameter 925 (Maximum Depth) to +2 ct.
 - In the LFO1 Menu, set Parameter 413 (Maximum Rate) to 0.08 Hz.
- Now, select Layer Parameter 202 (Duplicate Layer) and press YES. The K1200 will create a second Layer for the current Program.
- Select Parameter 213 (Detune) of Layer 2 and set it to 10 ct.

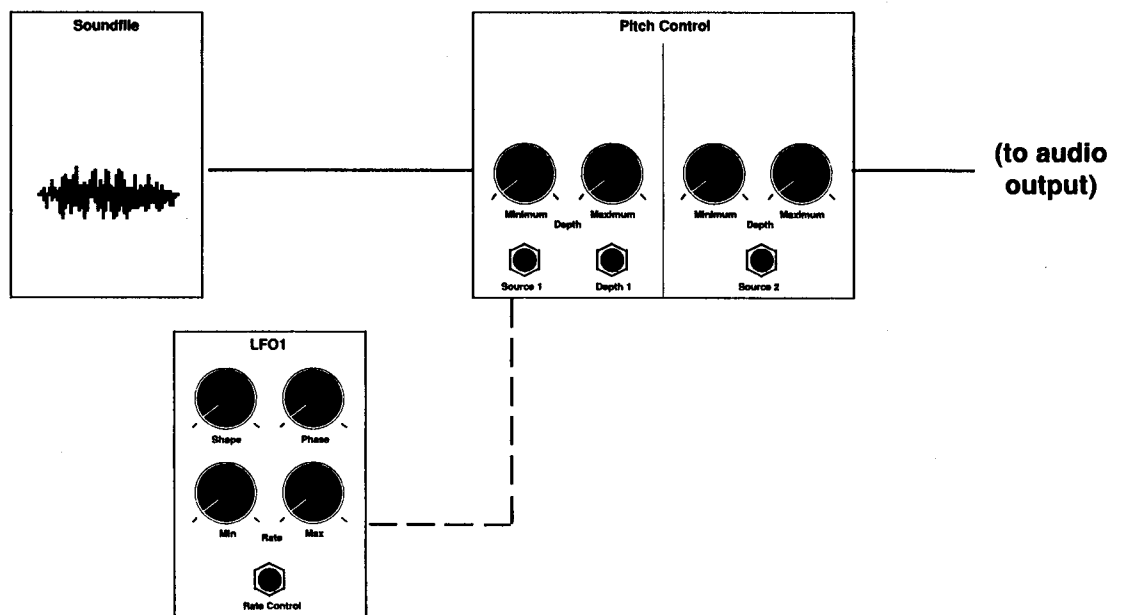

Figure 10-3 Chorus Effect (Each of Two Layers)

Section X

10.5 Leslie

-
- Move to Parameter 413 (Maximum Rate) of Layer 2 and set it to 0.05 Hz.

When you play your keyboard, you will hear that each note now has a slow, irregular varying chorus effect imposed on it. The density of the effect will change as you play thicker chords with different start times for individual notes.

You can elaborate on this patch by assigning different Control Sources to Parameters 414 (LFO1 Rate Control) and 923 (Pitch Control Modulation Depth 1). Greater Values for Parameters 413 (LFO1 Maximum Rate) and 925 (Pitch Control Maximum Depth 1) will produce more extreme effects.

The Leslie effect originated with a special loudspeaker cabinet that was made for Hammond electric organs. Within this cabinet, both the high-frequency and the low-frequency driver elements were coupled to a motor drive shaft that made them physically rotate. When the motor was switched on, a distinctive combination of pitch and amplitude modulation was produced as the elements whirled around in the cabinet.

We can approximate this effect with the patch in Figure 10-4 (next page). This complicated, two-Layer patch provides programmed pitch and amplitude modulation by two Global LFOs, controllable by the K1200's Modulation Wheel. To create this patch:

- Select the "Palette" Program and enter Edit Mode. Optionally, select a different Soundfile for the new patch.
- Following the instructions in Section 10.2 and 10.3, give the current Layer both a vibrato effect and a tremolo effect, but with the following changes:
 - Make gLFO1 the Modulation Source for the Amplitude Control Module, and gLFO2 the Source for the Pitch Control.

- In the Pitch Control Menu, set Parameter 924 (Minimum Depth 1) to -6 ct and Parameter 925 (Maximum Depth 1) to -14 ct. Set Parameter 923 (Modulation Depth 1) to MWheel.
- In the Amplitude Control Menu, set Parameter 944 (Minimum Depth) to -3 dB and Parameter 945 (Maximum Depth) to -9 dB. Set Parameter 943 (Modulation Depth) to MWheel.
- In the gLFO1 Menu, set Parameter 432 (Minimum Rate) to 3.60 Hz and Parameter 433 (Maximum Rate) to 7.50 Hz.
- In the gLFO2 Menu, set Parameter 442 (Minimum Rate) to 3.60 Hz and Parameter 443 (Maximum Rate) to 6.30 Hz. Set Parameter 445 (Shape) to +Cosine.
- Now, select Layer Parameter 202 (Duplicate Layer) and press YES. The K1200 will create a second Layer for the current Program.
- In the Pitch Control Menu of Layer 2, set Parameter 924 (Minimum Depth 1) to +6 ct and Parameter 925 (Maximum Depth 1) to +14 ct.

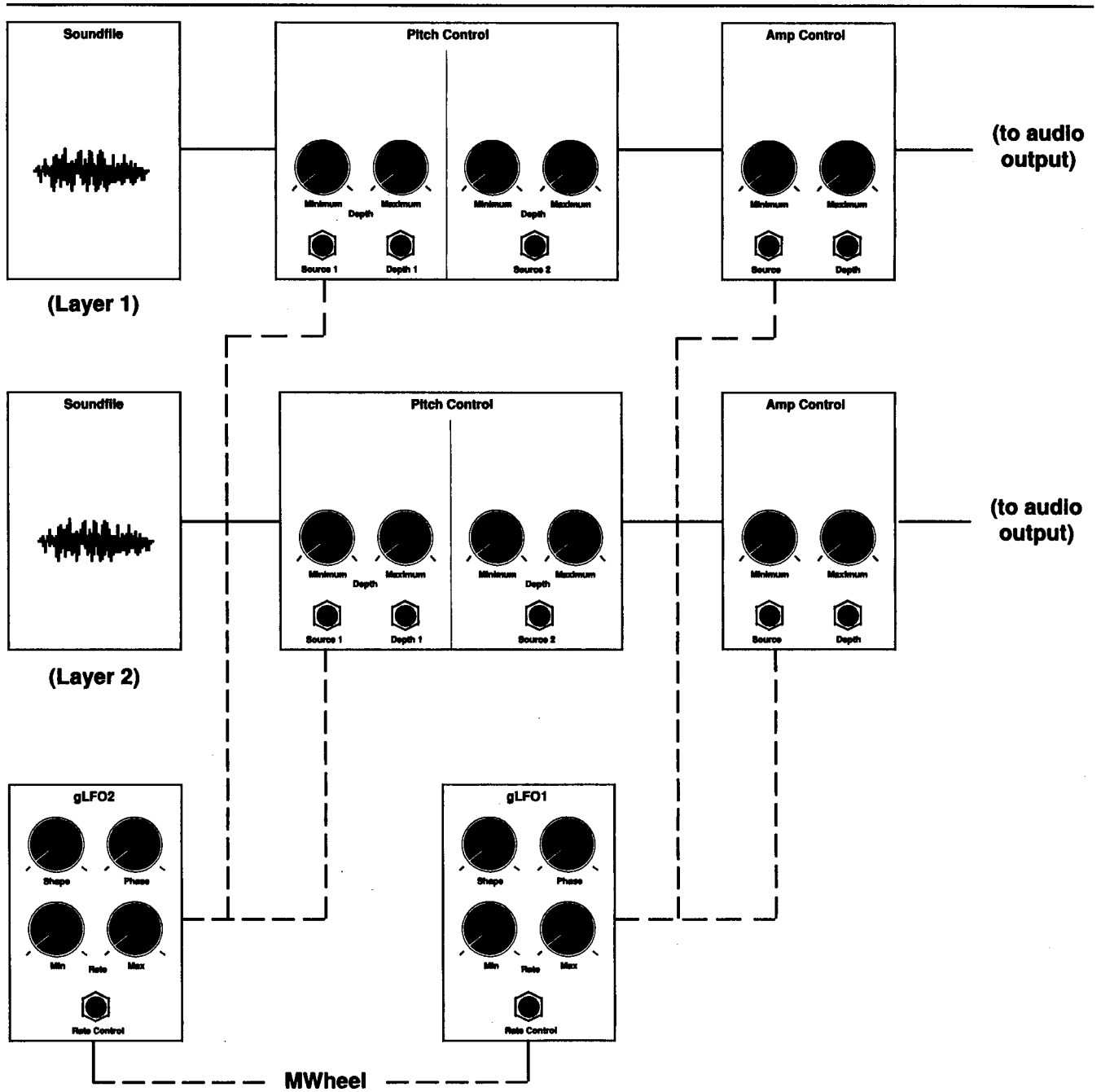

Figure 10-4 Leslie Effect

Section X

10.6 Using Velocity Triggers to Change Sounds

- In the Amplitude Control Menu of Layer 2, set Parameter 944 (Minimum Depth) to +3 dB and Parameter 945 (Maximum Depth) to +9 dB.

When you play your keyboard, you will hear that the Program now has a slow, regular Leslie effect imposed on it. Adjusting the Mod Wheel should vary the intensity of the effect.

Some K1200 Programs (like the Dual Electric Piano and Dual Bass) use dual Soundfiles. A Program with a dual Soundfile has access to two different sounds, even if there is only one Layer in the Program. The Electric Piano, for example, has a lot more “bite” when you play it hard—a bright sound is triggered by high velocities and a darker sound is triggered by low velocities.

The change in the Soundfiles in these kinds of programs is related to Note On Velocity. Each portion of the dual Soundfile is programmed to play within a specific range of Note On Velocities.

You can create a similar effect in a two-layer Program, using a Velocity Trigger. The Velocity Trigger can be used to bring in an additional Layer—one with the same Soundfile or a complete different one—or to cut out the first Layer and play only the second one. This is useful for building Programs with timbre changes based on Note On Velocity, and for Programs which allow you to get two completely different sounds from the same key of your keyboard. Velocity Triggers can be used for many other purposes as well, but the effect described here is one of the most popular.

Here’s how to build a Program which will play one sound when you play soft, and a different sound when you play hard:

Create a two-layer Program by adding a Layer to an existing one-Layer Program. Choose a Soundfile for Layer One (we’ll call it Sound One), and a different Soundfile (Sound Two) for Layer Two. For each Layer, set the Value of Layer Enable (Layer Parameter 217) to VTrig 1. (There are two VTrigs for each Layer; use whichever you want, but keep track of your assignments.) Then select the VTrig 1 Parameter (Layer Parameter 232) for Layer One and set it to the level where you want the crossover to occur (ff is good for this example). Do the same for Layer Two.

If you test your work at this point, you should hear nothing if you play softer than the level you set for the VTrigs, and both Layers when you play above the VTrig threshold. If so, you’re on the right track.

To set things up so that the sounds switch from soft to loud, you’ll need to reverse the VTrig 1 Sense for one of the Layers. If you’ve set the VTrig at ff, and you want to hear Layer One when you play soft and Layer Two when you play hard, then select Layer One and locate the VTrig 1 Sense Parameter (Layer Parameter 233). Set its Value to Rvrs. At this setting, Layer One

10.7 Performance Setups and MIDI

will play when the Note On Velocity is below the threshold set for VTrig 1. Leave the VTrig 1 Sense setting for Layer Two at Norm, and Layer Two will play only when the Note On Velocity is above the VTrig 1 Threshold.

If you're using your K1200 as the MIDI Master in a MIDI system which connects several MIDI devices together, you can use Performance Setups very effectively to give you the ability to change Programs in both your K1200 and your Slave devices—right from the front panel! Here's a simple example, which should give you ideas for your own MIDI system.

Let's assume that you have your K1200 controlling just one Slave, and you're using a PSetup with the center Region across the entire keyboard. You want to be able to select a PSetup, solo with it for a while, then layer it with your Slave synth. You also want to be able to change Programs just on your K1200, or just on your Slave synth.

Briefly, what you want to do is to create and save three PSetups, all with the same Split points (C0 and C8 in this case), and all with their Center Regions transmitting on the same MIDI channel. One of the PSetups will enable you to control just the K1200, one will control your MIDI Slave, and the third will enable control both locally and over MIDI.

Start by entering EDIT Mode, and selecting Parameter 044 Edit PSetup? Answer YES, then answer YES again to rename the PSetup (see Section 4.4.1 if you need help). Name it some-

thing that will help you remember its purpose. We'll call it "MIDI 1" for this example—it will be the MIDI-controlling PSetup, and it will transmit its Center Region on Channel 1.

When you've named the new PSetup, scroll to Parameter 2005, Keyboard Mode. Set the Values for Parameters 2005 - 2010 to "MIDI."

Leave the Values for Parameters 2011 - 2014 unchanged.

Set the Value of Parameter 2015 to Volume. This converts the Data slider into a Volume slider whose effect will be controlled by the Wheel Mode Value.

Leave the Values of Parameters 2016 and 2017 to C0 and C8, respectively. You can skip Parameter 2018 altogether.

Make sure the Value of Parameter 2019 is set to 1—this is the Center Region's MIDI channel.

Leave the Value of Parameter 2020 set to 0.

Set the Value of Parameter 2021 to "None."

Next, select the Left Region (press A and B together), and return to Parameter 2005. Set the Values for Parameters 2005 - 2010 to "Off" for the Left Region. Parameters 2011 - 2017 can remain as they are. Set

Section X

Parameter 2019 to "Off," Parameter 2020 to 0, and Parameter 2021 to "None."

Repeat this process for the Right Region.

Now select Parameter 2002, answer YES, and the PSetup called "MIDI 1" will be stored in RAM.

Now press PLAY/EDIT, and you will return to Parameter 044 Edit PSetup? Answer YES. Parameter 2001 will appear. Answer YES, and the name "MIDI 1" will appear. Change the name to "Local 1." Then repeat the programming steps outlined above. In the Center Region, change the Values of Parameters 2005 - 2010 to "Local." All other Parameters for the Center Region can remain the same.

Since the PSetup you're now editing is a copy of your PSetup "MIDI 1" (it was automatically selected when you saved it), you won't have to select the Left and Right Regions to edit them. Their settings remain the same in all three PSetups.

When you've finished editing the PSetup "Local 1," save it, then return to Parameter 044, answer YES, answer YES to Parameter 2001, and name the next PSetup "Both 1" (controlling both the K1200 and MIDI, and transmitting on channel 1).

Repeat the process for the Center Region of "Both 1," setting the Values for Parameter 2005 - 2010 to "Both." When you're finished editing, save the PSetup.

Store the three PSetups in Bins for quick access (see Section 6.7 if you need help with Bin Map editing). Now your trio of Psetups is ready to use.

Select the PSetup "MIDI 1." You should be able to play your Slave synth (whatever Program was last selected), without hearing your K1200. You can change Programs on the Slave synth using the K1200's PROGRAM buttons, or the ENTER and numeric buttons.

Now select the PSetup "Local 1," and you'll be able to play the K1200 without playing the Slave synth, and without affecting its current Program selection. You can change Programs on the K1200 without changing Programs on the Slave synth.

Finally, select the PSetup "Both 1," and your K1200 and the Slave synth will be layered together. Program changes you make from the K1200's front panel will be sent to the Slave synth.

If one of the sounds is too loud, select the appropriate PSetup, adjust the volume with the data slider (which you programmed

to send Volume information), then return to the PSetup "Both" to hear the sounds layered and remixed.

10.8 Conclusion

These relatively simple examples only hint at the true programming power of the K1200. By carefully studying this *Programming Reference* and experimenting with your 1200's editing features, you will learn how to harness that power.

As an aid in learning about Effects editing, you can study the 1200's preprogrammed Compiled Effects. Assign a preset Compiled Effect to your "Palette" Program, then use Parameter 216 (Efx Edit Level) to change the Efx Edit Level to Modular. This will give you access to the Modular Effects Menus, allowing you to scroll through their Parameters and study the programmed Values for the Compiled Effect. (Changing from the Compiled to Modular Effects Level will also give you access to the "invisible" Layers generated by the more complex Compiled Effects.) You can also edit these Values, and then save the current Program to a RAM location.

Note — If you return to the Compiled Effects Level before saving a Program which you

have modified in this fashion,
you will lose your changes.
When you change from Modular
to Compiled Effects, the con-
nections between Modules are
removed and replaced with the
pre-programmed patches of the
selected Compiled Effect.

By applying your own personal
creativity to Modular Effects
editing, you can create a wealth
of Programs that are uniquely
yours, tailored to your personal
musical style. And as you gain
proficiency with the K1200's
editing features, you'll find that
the instrument allows you
plenty of room to grow. In that
process, it's important to re-
main open to the unexpected.

Section XI

REFERENCE

11.1 Functions of Buttons in the Naming Sequence

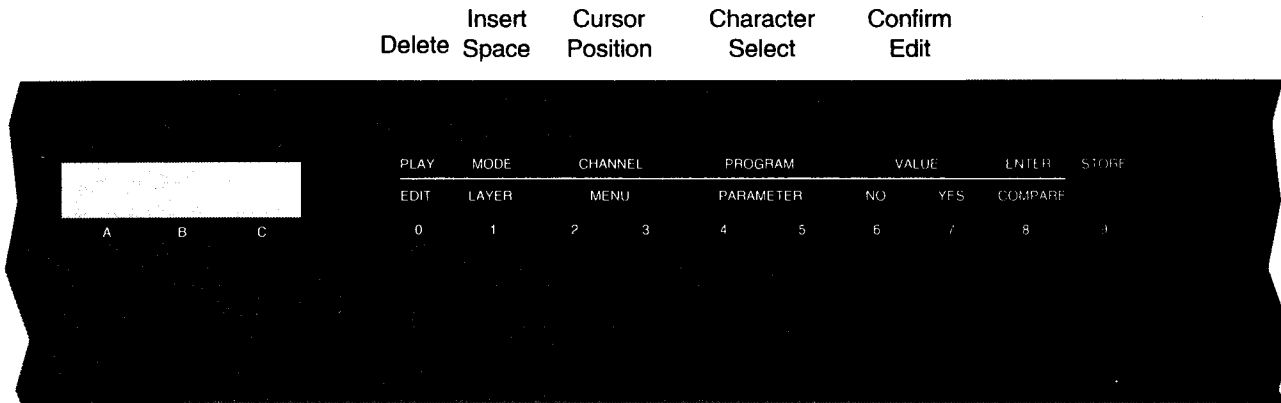

11.2 Performance Functions of Buttons in PLAY Mode

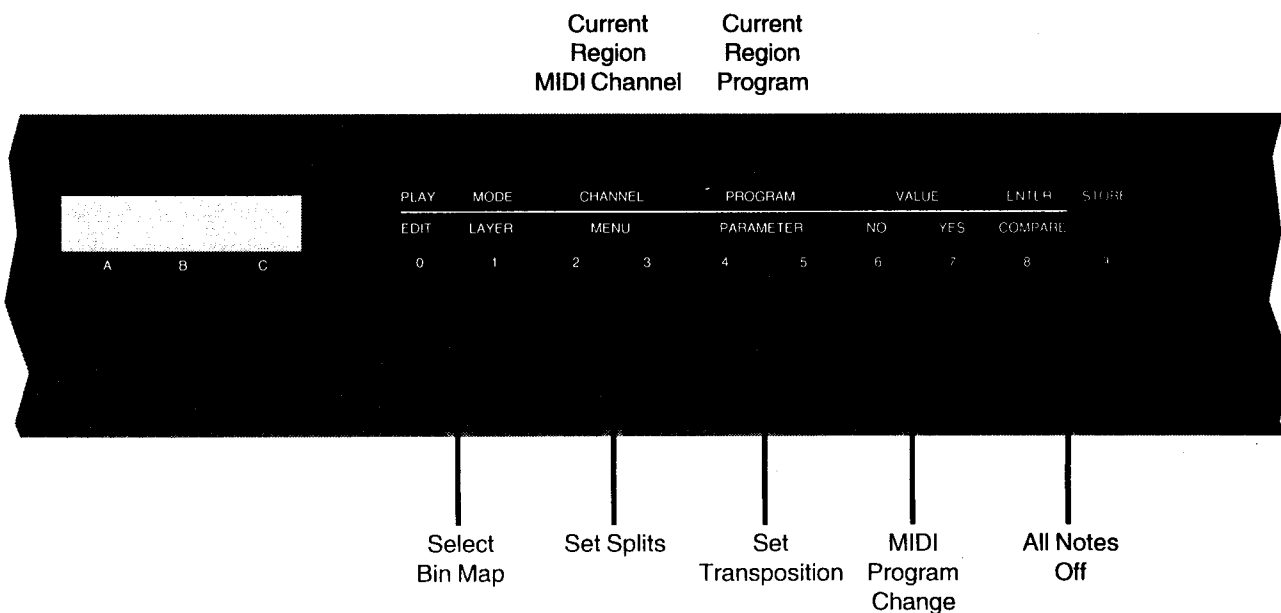

11.3 Compiled Effects Parameters

Vibrato		Vibrato / Chorus 2*	
[301]	Maximum Depth	[301]	Maximum Rate
[302]	Maximum Rate	[302]	Maximum Depth
[303]	Shape	[303]	Shape
[304]	Depth Control	[304]	Rate Control
[305]	Rate Control	[305]	Depth Control
Delay Vibrato		[306]	Transpose
[301]	Maximum Depth	[307]	Detune
[302]	Maximum Rate	[308]	Delay
[303]	Shape	[309]	Enable
[304]	Delay	[310]	Pan 1
[305]	Ramp	[311]	Pan 2
[306]	Rate Control	Phaser 2*	
Tremolo		[301]	Maximum Rate
[301]	Maximum Depth	[302]	Depth
[302]	Maximum Rate	[303]	Ramp
[303]	Shape	[304]	Shape
[304]	Depth Control	[305]	Rate Control
[305]	Rate Control	[306]	Detune
Delay Tremolo		[307]	Delay
[301]	Maximum Depth	[308]	Pan 1
[302]	Maximum Rate	[309]	Pan 2
[303]	Shape	Leslie 2*	
[304]	Delay	[301]	Rate
[305]	Ramp	[302]	Depth
[306]	Rate Control	[303]	Ramp
Leslie		[304]	Trigger
[301]	Rate	[305]	Pan 1
[302]	Depth	[306]	Pan 2
[303]	Ramp	Chorus 3*	
[304]	Trigger	[301]	Transpose
Chorus 2*		[302]	Detune
[301]	Transpose	[303]	Delay
[302]	Detune	[304]	Enable
[303]	Delay	[305]	Pan 1
[304]	Enable	[306]	Pan 2
[305]	Pan 1	[307]	Pan 3
[306]	Pan 2	Echo 3*	
Tremolo 2*		[301]	Delay
[301]	Maximum Rate	[302]	Decay
[302]	Maximum Depth	[303]	Enable
[303]	Shape	[304]	Pan 1
[304]	Rate Control	[305]	Pan 2
[305]	Depth Control	[306]	Pan 3
[306]	Pan 1		
[307]	Pan 2		

*Uses additional "invisible" Layers.

Section XI

11.4 1000 Series Control Source List

Name	Display	Config	Type
Off	OFF	Logical	Global
On	ON	Logical	Global
None	None	—	—
Modulation Wheel (MIDI 01)	M Wheel	Unipolar	Global
Breath Controller (MIDI 02)	Breath		
MIDI 03	MIDI 03		
Foot Switch (MIDI 04)	Foot		
Portamento Time (MIDI 05)	PortTim		
Data Entry (MIDI 06)	Data		
Volume (MIDI 07)	Volume		
Balance (MIDI 08)	Balance		
MIDI 09	MIDI 09		
Stereo Pan (MIDI 10)	Pan		
Expression (MIDI 11)	Express		
MIDI 12	MIDI 12		
MIDI 13	MIDI 13		
MIDI 14	MIDI 14		
MIDI 15	MIDI 15		
Performance Control A (MIDI 16)	Ctl A		
Performance Control B (MIDI 17)	Ctl B		
Performance Control C (MIDI 18)	Ctl C		
Performance Control D (MIDI 19)	Ctl D		
MIDI 20	MIDI 20		
MIDI 21	MIDI 21		
MIDI 22	MIDI 22		
MIDI 23	MIDI 23		
MIDI 24	MIDI 24		
MIDI 25	MIDI 25		
MIDI 26	MIDI 26		
MIDI 27	MIDI 27		
MIDI 28	MIDI 28		
MIDI 29	MIDI 29		
MIDI 30	MIDI 30		
MIDI 31	MIDI 31		
Sustain Pedal (MIDI 64)	Sustain		
Portamento Switch (MIDI 65)	Port Sw		
Sostenuto Pedal (MIDI 66)	Sost Pd		
Soft Pedal (MIDI 67)	Soft Pd		
MIDI 68	MIDI 68		
Freeze Pedal (MIDI 69)	Frez Pd		
MIDI 70	MIDI 70		
MIDI 71	MIDI 71		
MIDI 72	MIDI 72		
MIDI 73	MIDI 73		
MIDI 74	MIDI 74		
MIDI 75	MIDI 75		
MIDI 76	MIDI 76		
MIDI 77	MIDI 77		

Name	Display	Config	Type
MIDI 78	MIDI 78	Unipolar	Global
MIDI 79	MIDI 79		
Performance Control E (MIDI 80)	Ctl E		
Performance Control F (MIDI 81)	Ctl F		
Performance Control G (MIDI 82)	Ctl G		
Performance Control H (MIDI 83)	Ctl H		
MIDI 84	MIDI 84		
MIDI 85	MIDI 85		
MIDI 86	MIDI 86		
MIDI 87	MIDI 87		
MIDI 88	MIDI 88		
MIDI 89	MIDI 89		
MIDI 90	MIDI 90		
MIDI 91	MIDI 91		
MIDI 92	MIDI 92		
MIDI 93	MIDI 93		
MIDI 94	MIDI 94		
MIDI 95	MIDI 95		
Pitch Wheel	P Wheel	Bipolar	Global
Monophonic Afterpressure	M Press	Unipolar	Global
Polyphonic Afterpressure	P Press	Unipolar	Local
Attack Velocity	Att Vel	Unipolar	Local
Release Velocity	Rel Vel	Unipolar	Local
Note State	Note St	Logical	Local
Key State	Key St	Logical	Local
Key Number	Key Num	Unipolar	Local
Local LFO 1 Output	LFO1	Bipolar	Local
Local LFO2 Output	LFO2	Bipolar	Local
Local LFO1 Phase	LFO1ph	Bipolar	Local
Local LFO2 Phase	LFO2ph	Bipolar	Local
Global LFO1 Output	gLFO1	Bipolar	Global
Global LFO2 Output	gLFO2	Bipolar	Global
Global LFO1 Phase	gLFO1ph	Bipolar	Global
Global LFO2 Phase	gLFO2ph	Bipolar	Global
Local ASR1 Output	ASR1	Unipolar	Local
Local ASR2 Output	ASR2	Unipolar	Local
Global ASR1 Output	gASR1	Unipolar	Global
Global ASR2 Output	gASR2	Unipolar	Global
Mixer 1 Output	MXR1	Bipolar	Local
Mixer 2 Output	MXR2		
Inverter 1 Output	INV1		
Inverter 2 Output	INV2		
Negator 1 Output	NEG1		
Negator 2 Output	NEG2		
Amplitude Envelope	Amp ENV	Unipolar	Local
Envelope 2	ENV2	Bipolar	Local
Velocity Trigger 1	VTrig1	Logical	Local
Velocity Trigger 2	VTrig2	Logical	Local
Inverted Attack Velocity	InvAVel	Unipolar	Local
Inverted Release Velocity	InvRVel	Unipolar	Local
Playback Rate	PB Rate	Unipolar	Local
Absolute Pitch Wheel	Abs P-Whl	Unipolar	Global
Bipolar Mod Wheel	Bi M-Whl	Bipolar	Global
Channel State	Chan St	Logical	Global

Section XI

11.5 Standardized MIDI Control Numbers

MIDI #	Name	1200 Display
01	Modulation Wheel	M Wheel
02	Breath Controller	Breath
04	Foot Controller	Foot
05	Portamento Time	PortTim
06	Data Entry	Data
07	Volume	Volume
08	Balance	Balance
10	Pan	Pan
11	Expression	Express
16	Performance A	Ctl A
17	Performance B	Ctl B
18	Performance C	Ctl C
19	Performance D	Ctl D
64	Sustain Pedal	Sustain
65	Portamento Switch	Port Sw
66	Sostenuto Pedal	Sost Pd
67	Soft Pedal	Soft Pd
69	Freeze Pedal	Frez Pd
80	Performance E	Ctl E
81	Performance F	Ctl F
82	Performance G	Ctl G
83	Performance H	Ctl H

The MIDI Control Sources listed above are standardized in the MIDI 1.0 Specification. Most manufacturers of MIDI equipment acknowledge these standards, and program their products according to the functions indicated by the names of these Control destinations. For further information regarding the MIDI implementation for equipment that you wish to use with your SE II, consult the manufacturer's documentation.

11.6 The Master Menu

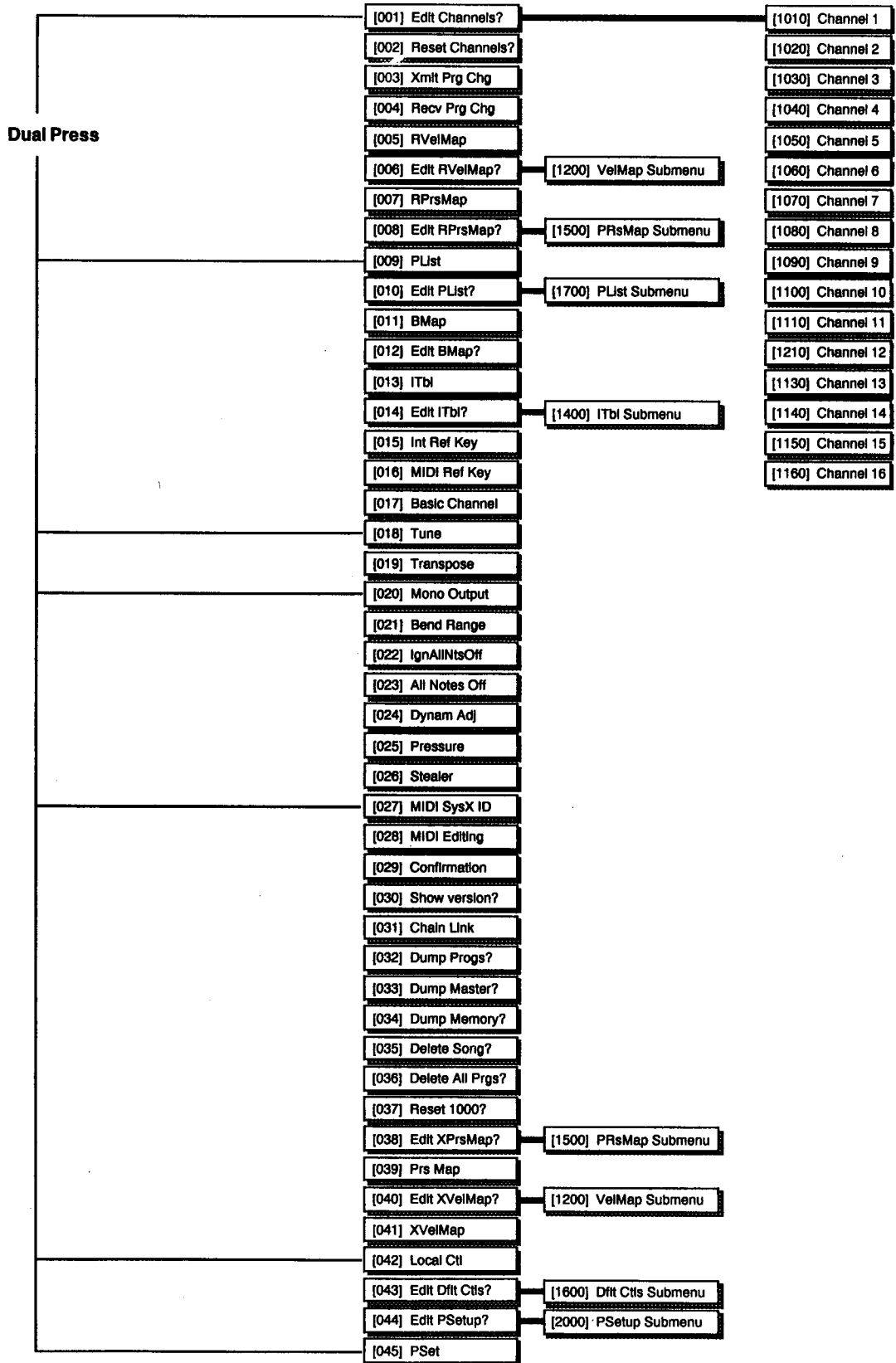

Section XI

11.7 The Program Menu

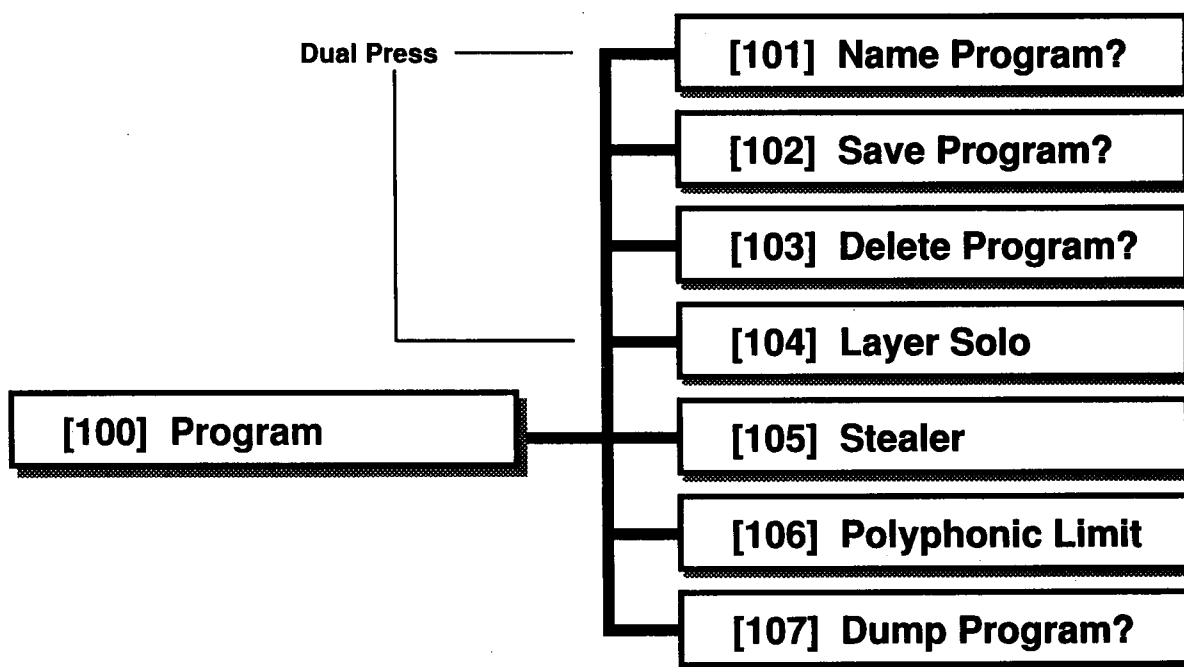

11.8 The Layer Menu

Dual Press

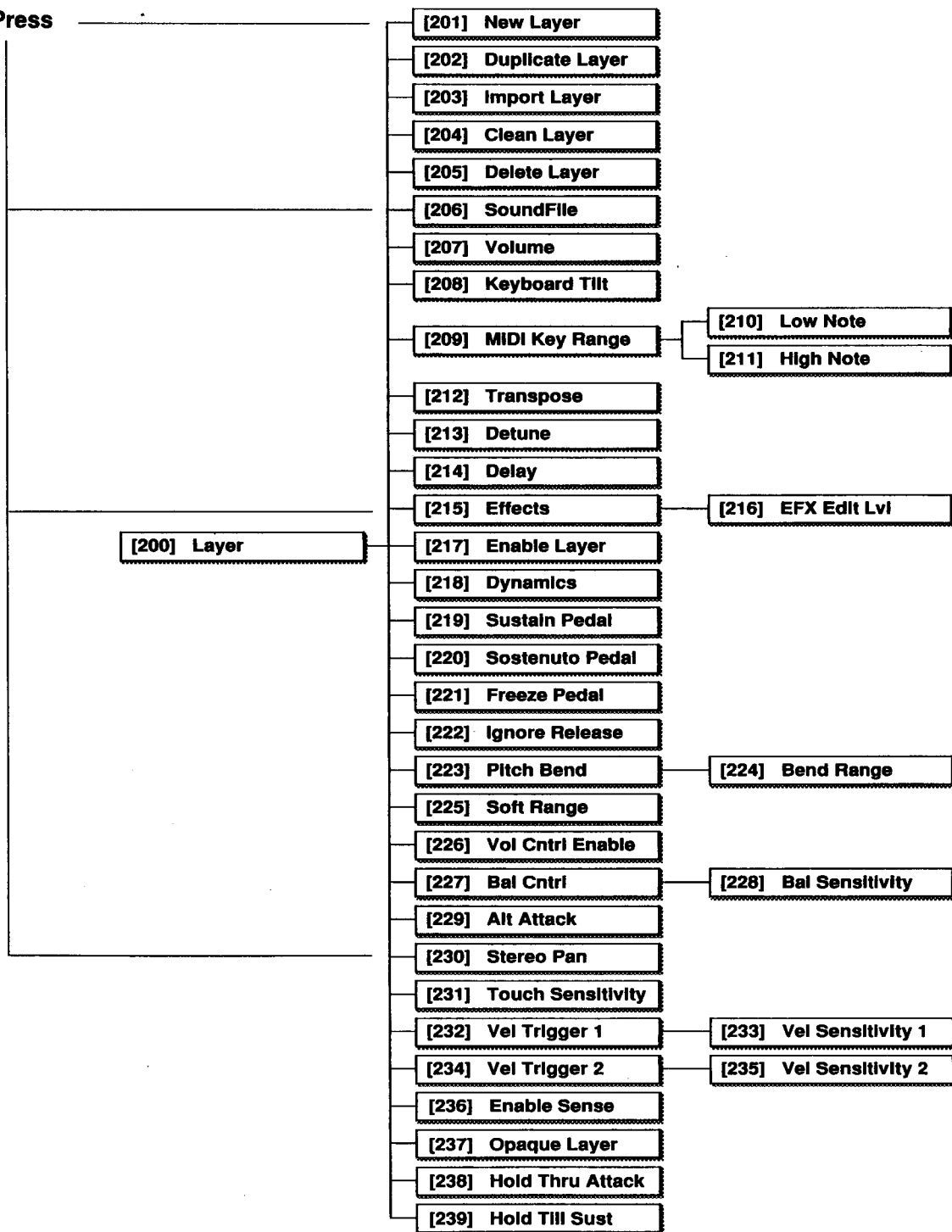

Section XI

11.9 Modular Effects Menus

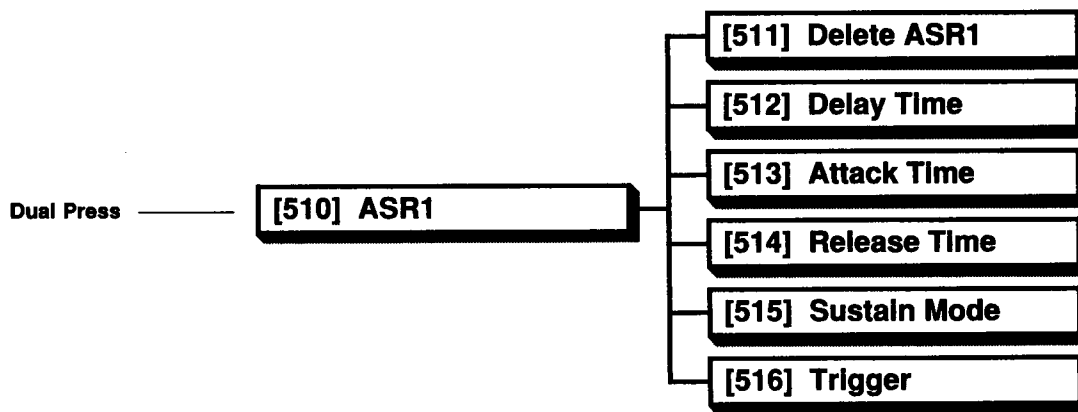
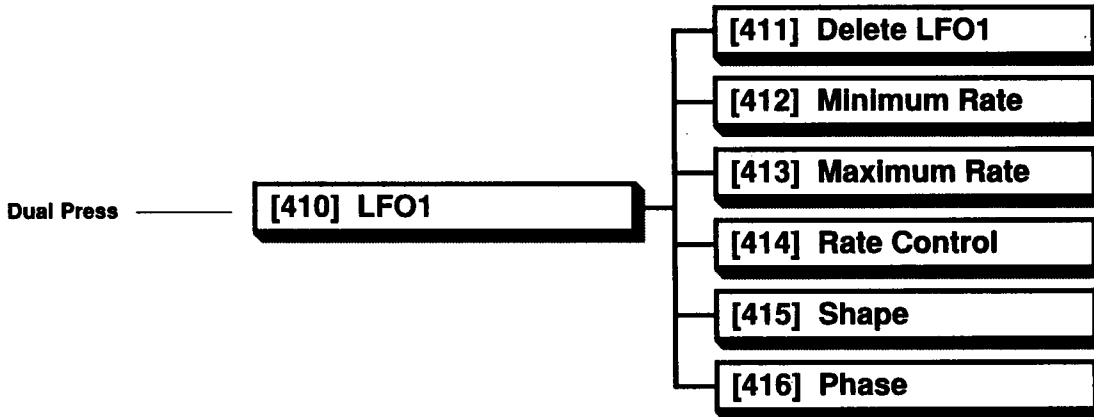

Dual Press

[600] Mixers

[601] Delete Mixer

[602] Mixer 1 Input 1

[603] Mixer 1 Input 2

[604] Mixer 2 Input 1

[605] Mixer 2 Input 2

Dual Press

[650] Inverters / Negators

[651] Delete Inv / Neg

[652] Inverter 1 Input

[653] Inverter 2 Input

[654] Negator 1 Input

[655] Negator 2 Input

Section XI

Dual Press

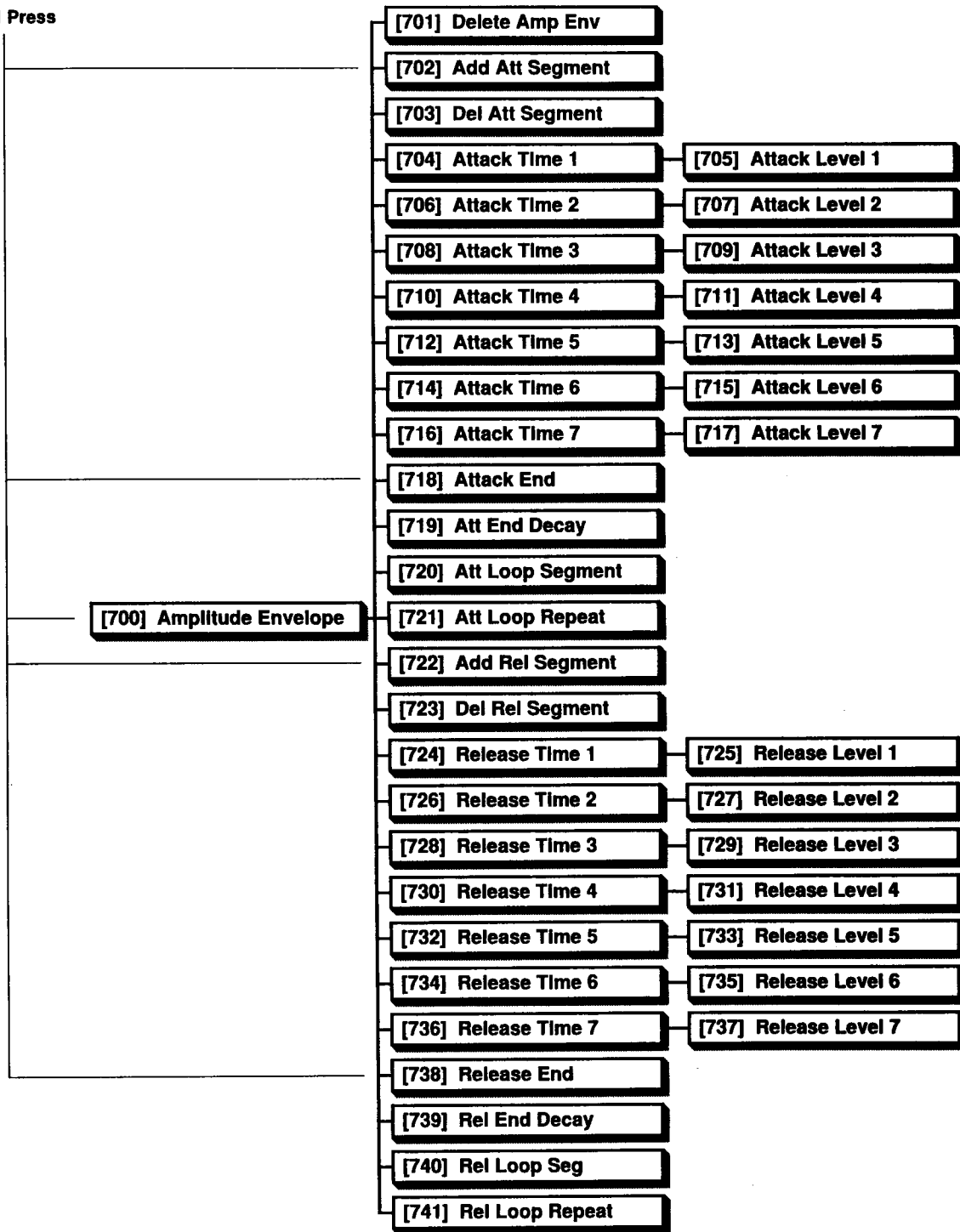

Dual Press

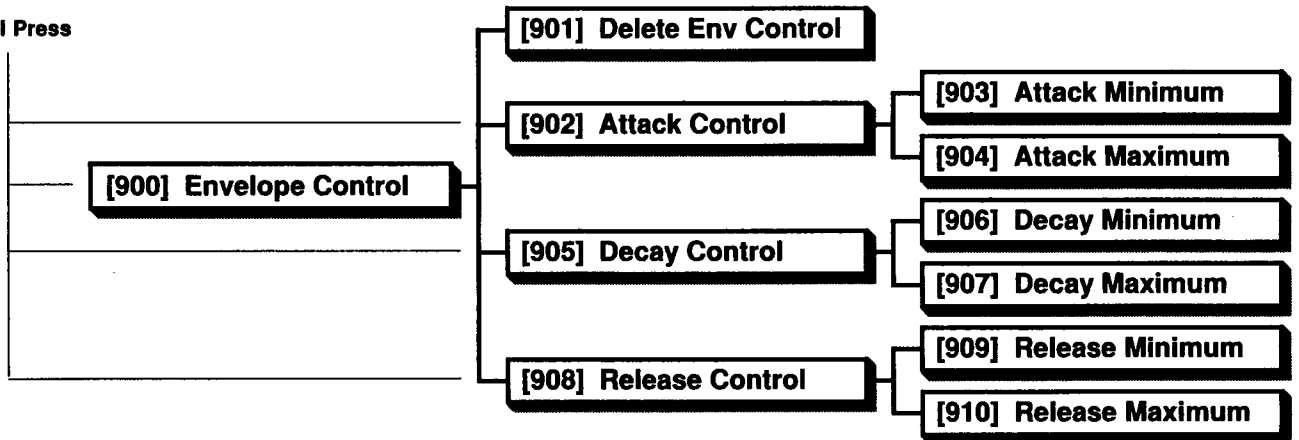

Dual Press

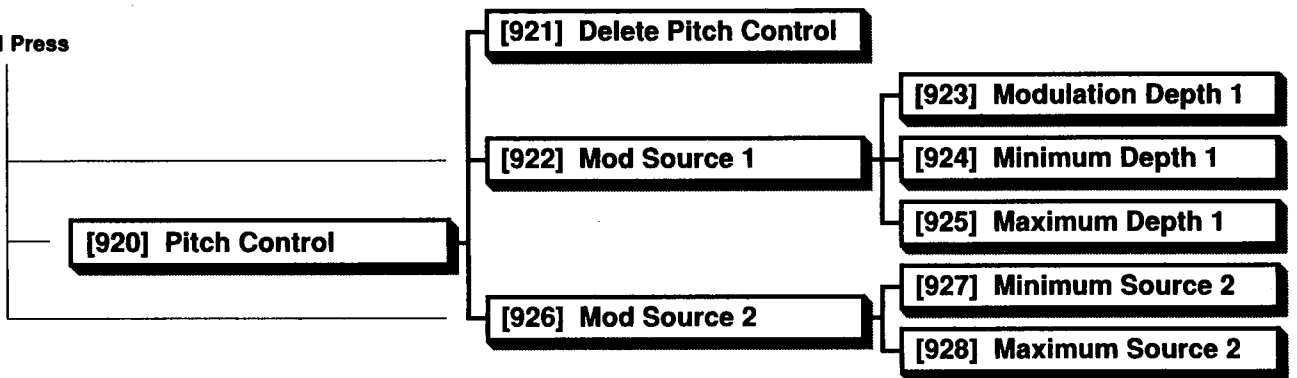

Dual Press

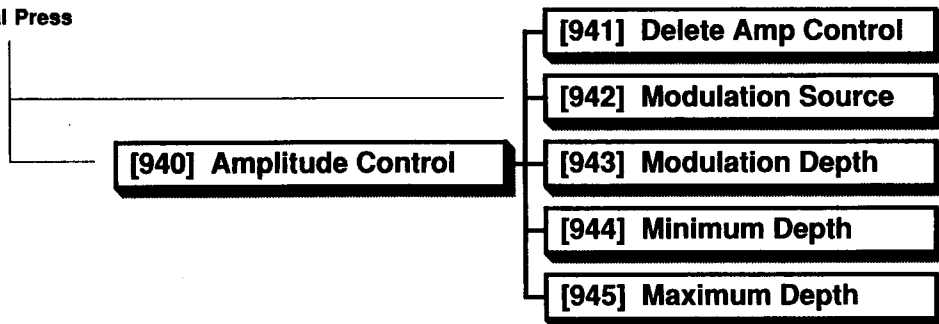

Section XII

A P P E N D I X

12.1 Value Resolutions

12.1.1 Time Values

In the K1200's Edit Menu, time is expressed in seconds, with a normal maximum resolution (amount of increase or decrease in Value with each button stroke) of 0.01 s. Time Values range from a minimum of 0.00 s to a maximum of 10.00 s.

As you scroll through the range of Values for a time-oriented Parameter, you will notice that the resolution *decreases* as the Value *increases*. By adjusting the minimum time increment upward as the Value increases, the 1200's software assures that, in each time range, you will be stepping by a perceptually significant increment. This feature speeds the editing process.

Figure 12-1 illustrates the 1200's normal editing resolution for each time Value range.

Range	Resolution
0.00 – 1.00 s	.01 s
1.00 – 2.00 s	.02 s
2.00 – 5.00 s	.05 s
5.00 – 9.00 s	.10 s
9.00 – 10.00 s	.20 s

Figure 12-1 Time Value Resolution For Various Ranges

Layer Delay — Parameter 214 (Layer Delay) is the only Parameter in the K1200 that allows greater than normal resolution over its entire range: the maximum resolution for Parameter 214 is one millisecond (0.001 s).

Kurzweil's software engineers have provided finer resolution for Layer Delay because it is the sole time-oriented Parameter for which very fine increments in Value can have a significant audible effect. Layer Delays may be used to produce a variety of effects, from chorusing (small delay Values) to strumming and echo effects (larger delay Values).

The resolution at various ranges for Parameter 214 is shown in Figure 12-2.

Range	Resolution
0.000 – 0.050 s	.001 s
0.050 – 0.100 s	.002 s
0.100 – 0.200 s	.005 s
0.200 – 0.500 s	.010 s
0.500 – 1.000 s	.020 s
1.000 – 2.000 s	.050 s
2.000 – 10.000 s	.100 s

Figure 12-2 Layer Delay Time Value Resolution

12.1.2 Rate Values

Rates are expressed in Hertz (cycles per second). As with Time Values, Rate Values have different resolutions in different ranges. Figure 12-3 illustrates the 1200's normal editing resolution for each rate (frequency) Value range.

Range	Resolution
0.00 – 0.20 Hz	.01 Hz
0.20 – 1.00 Hz	.05 Hz
1.00 – 10.00 Hz	.10 Hz
10.00 – 20.00 Hz	.20 Hz
20.00 – 50.00 Hz	.50 Hz

Figure 12-3 Rate Value Resolution For Various Ranges

12.2 Self-Diagnostics

The K1200's software includes a set of diagnostic routines which you can run yourself. If you suspect a malfunction in your K1200, you can use these diagnostics to help determine whether the unit needs to be serviced.

WARNING: The RAM test—part of the self-diagnostics—will completely erase the K1200's Random Access Memory. This will delete all of the programming changes you have made to the 1200, including User Programs, Master Parameter settings, and control settings. Before performing the self-diagnostics on your K1200, you should save your programming work using ObjectMover.™ If you do not have ObjectMover, you may not wish to perform the self-diagnostics.

To enter self-diagnostic mode, first turn the K1200 off. Connect a MIDI cable from the MIDI Out port to the MIDI In port. Hold down the "C" and PLAY/EDIT buttons, and turn the unit back on.

Important — Set the Volume Slider to minimum. The Sound ROM Test generates full-volume waveforms which may damage your audio system.

The display will briefly show something like:

K1000KXA	Test
Supervisor	v1.50

It then will show:

```
KDIAGS MAIN MENU
>BURN IN
```

Press the PROGRAM UP button, and the display will respond:

```
KDIAGS MAIN MENU
>RUN ALL
```

Press YES, and the display will read:

```
NUMBER OF PASSES
> 1
```

Press YES again to begin the test sequence.

The display will identify each test while it is running, as follows:

```
Program ROM Test
Setup ROM Test
RAM Test
Battery Backup Test
Timer Test
UART Test
VLSI 1 Test
VLSI 2 Test
Sound ROM Test
One Sample Test
```

Eventually you will see a display for the Sine Wave test:

```
SINE WAVE
Step 1          1000 Hz
```

Press any button to step through the Sine Wave test's 11 steps, or Press NO to skip to the next test, the LCD test. This test runs automatically. When

it is finished, the button test begins. Pressing each button in turn should display the button's function.

Press NO twice to exit the button test. When you do, the display will show a test summary:

```
PASSES>00001
ERRORS>00000
```

If the display shows anything other than 00000 for the number of errors, call your Kurzweil deal.

Note—If you do not make the MIDI cable connection loop described above, the K1200 will register one test failure, and will generate a number of error messages. The error displays will last for only a few seconds each, and will not interrupt the test. At the end of the test summary, the display will show which test failed.

A failed MIDI loop test probably does not indicate a malfunction.

After displaying the tests results, the K1200 will return to the ">BURN IN" display. Press the PROGRAM DOWN button, and the display will read:

```
KDIAGS MAIN MENU
>EXIT
```

Press YES, and the K1200 will return to Play Mode.

ID#	PRODUCT				1000 Series Sysex Messages, continued...
\$15					150 FS
\$19 (25)					K250 or 250 RMX
\$64 (100)	\$01	\$00	\$00		1000PX
	\$01	\$05	\$00		AX PLUS
	\$01	\$01	\$01		PX PLUS
	\$01	\$03	\$00		1000HX
	\$01	\$02	\$00		1000SX
	\$01	\$04	\$00		1000GX
	\$02	\$01	\$00		K1000 SE
	\$03	\$01	\$01		1000EX
	\$04	\$01	\$00		EGP
p1	p2	p3	p4		

e1, e2, s1, and s2 represent the hexadecimal values indicating the software version of the unit, e1 and e2 indicate the engine (operating system) software, which is common to groups of Kurzweil products. s1 and s2 indicate the setup software. It is the setup software which distinguishes a GX from an AX, etc. For both engine and setup software, the first numeral is the major version number, and the second is the subversion, if any. For example, version 1.0 would be represented as \$01 \$00. Version 2.14 would be \$02 \$0E (2 14 in decimal).

REMOTE FRONT PANEL

The remote front panel messages allow control of the K1200's front panel over MIDI. The format of the message is

\$F0 \$07 <device ID> \$64 \$01 <buttons> \$F7
 where \$64 (100) is the major product ID (i.e., 1000 series) and <buttons> is any of a number of button codes:

CODE BUTTON

\$00	(0)	digit '0'
.	.	.
.	.	.
.	.	.
\$09	(9)	digit '9'

Section XII

1000 Series Sysex Messages, continued...

CODE	BUTTON
\$10	(16) play/edit
\$11	(17) mode/layer
\$12	(18) chan/menu increment
\$13	(19) chan/menu decrement
\$14	(20) chan/menu incr & decr (double press)
\$15	(21) prog/param increment
\$16	(22) prog/param decrement
\$17	(23) prog/param incr & decr (double press)
\$18	(24) value increment/yes
\$19	(25) value decrement/no
\$1A	(26) value incr & decr (double press)
\$1B	(27) enter
\$1C	(28) store
\$20	(32) bank 'A'
\$21	(33) bank 'B'
\$22	(34) bank 'C'
\$7F	(127) send display

Whenever the special "send display" button (\$7F) is sent, the 1200 responds with

\$F0 \$07 <device ID> \$64 \$02 <display text> \$F7

where <display text> is the content of the 1200 display as ordinary ASCII characters.

DUMP REQUEST MESSAGE

\$F0 \$07 <device ID> \$64 \$03 <type-msb> <type-lsb> <ID-msb> <ID-lsb> <RAM-flag> \$F7

This message may be used to request a dump of any object or group of objects in the 1000's memory. The type and ID number select the object to be dumped. A type of \$00 means all types and an ID number of \$00 means all objects of the requested type. If the RAM-flag is TRUE (i.e., not zero) only objects stored in non-volatile RAM will be dumped. For example, to request a dump of all RAM based programs, use:

\$F0 \$07 <device ID> \$64 \$03 \$00 \$50 \$00 \$00 \$01 \$F7

To request a dump of the Master Parameter Table, use:

\$F0 \$07 <device ID> \$64 \$03 \$00 \$42 \$00 \$00 \$01 \$F7

To request a memory dump (User Objects and RAM), use:

\$F0 \$07 <device ID> \$64 \$03 \$00 \$42 \$00 \$10 \$01 \$F7

CHANNEL SETUP MESSAGE

\$F0 \$07 <device ID> \$64 \$04 <chan a> <mode a> <chan b>
<mode b> etc... \$F7

This message may be used to set the MIDI mode (Omni, Poly or Multi) and to enable or disable specific MIDI channels. If <chan a> (or subsequent) = \$00, then it signals a mode change. A value of \$01 for <mode a> (or later) indicates Omni mode, \$02 is Poly, and \$03 is Multi.

If <chan b> or subsequent is \$01 through \$10 (16), it is read as a MIDI channel number. In this case, the following <mode> byte value determines whether that MIDI channel is active. \$00 enables the channel, and \$01 disables it. For example, to put the instrument in Multi mode, with channels 1 thru 4 enabled, use:

\$F0 \$07 <device ID>	\$64	\$04	\$00	\$03	; multi mode
	\$01	\$00	\$02	\$00	
	\$03	\$00	\$04	\$00	; enable 1-4
	\$05	\$01	\$06	\$01	
	\$07	\$01	\$08	\$01	
	\$09	\$01	\$0A	\$01	
	\$0B	\$01	\$0C	\$01	
	\$0D	\$01	\$0E	\$01	
	\$0F	\$01	\$10	\$01	; disable 5-16

\$F7

Section XII

12.4 Demo Object Format

A RAM based Demo object is basically a MIDI File, Type 0, with a 1000 Series object header prepended to it. Demo songs may be loaded, named, renumbered or removed with ObjectMover. A separate program is needed to turn MIDI files into object files.

This section details the format of these object files for people wishing to write their own Demo object convertor programs.

The Demo object format is defined by the following "C" type definitions:

```
/* DemoTypes.h */
/* Data structure definitions for 1200 Demo objects */

/* file type, first longword in file */
#define SRROM          0x53524F4D

/* Demo object type and id declarations */
#define Demo1200       0x5B
#define DemoIDBase    1

/* object file header, one per file */
typedef struct {
    long DO_type;          /* Demo (SRROM) */
    word DO_rfu[14];      /* must be 0 */
    long DO_blockSize;    /* negative block size */
} dFHdr;

/* song header, one per song */
typedef struct {
    char DS_objType;      /* 0x5B is a Demo song */
    char DS_objID;        /* id (1..255) */
    word DS_objSize;      /* size of object */
    long DS_tempo;        /* actual initial beat increment */
} demoSong;

/* name of the object goes here, before the song itself */
/* (must be null terminated, even number of bytes) */
```

There may be more than one Demo song in an object file, in which case, there would be multiple song headers. All song objects must be word aligned. The Demo player will play them in the order of their resource IDs, in a repeating cycle.

A note on the MIDI data itself. It is recommended that your program remove, or truncate text meta-events from the data stream. Only the tempo meta-event is interpreted by the 1200. You can save precious memory space by removing unused meta-events. (Meta-events are defined in the MIDI Standard File document). Meta-events encountered by the Demo player are treated as null events and skipped.

The Demo player cannot play SysEx data recorded in the song. It should be stripped from the Demo object.

Here is a dump of the beginning of an actual 1200 Demo object file:

DO_blockSize	DO_type	DS_objType	DS_objID	DS_objSize	DS_tempo	Name
000000:	5352 4F4D	0000	0000	0000 0000	0000 0000	SR0M.....
000010:	0000 0000	0000	0000	0000 0000	0000 0000
000020:	FFFF F27E	5B08	0D7D	0005 1E00	5A6F 6D62	...~[...}...Zomb
000030:	6965 2052	6167	2023	382E 7479	7065 3000	ie Rag *8.type0.
000040:	00C0 0183	0190	4A5A	003C 4001	465F 816FJZ.<@.F..o
000050:	803C 407A	4A49	1E46	2E84 2990	4A5C 821E	.<@zJI.F..).J\..
000060:	804A 2B85	1290	225C	042E 6222	4D62 5180	.J+..."\.b"MbQ.
000070:	2258 262E	6A82	604D	2B83 2490	3A2D 213E	"X&.j.`M+.\$.:~!>
000080:	4A18 355A	4C80	3E62	433A 7530	355C 8231	J.5ZL.>bc:u05\..1
000090:	904D 4482	6580	4D2D	6990 1D65	094A 540A	.MD.e.M-i..e.JT.
0000A0:	295A 810F	801D	5A05	2954 814D	4A28 8415	>Z....Z.>T.MJ<..
0000B0:	903A 5726	3E58	1D35	5821 4D50	4380 3E54	..W&>X.5X!MPC.>T
0000C0:	343A 6A27	355C	2F4D	2985 2E90	2E6F 0522	4:j'5\ M)....o."

Start of MIDI File, Type 0, data

The block size in the object header is the size of all the objects in file, negated. (The 1200 Memory Manager uses this negation internally). The blockSize must include everything from itself to the end of file, so you will calculate DO_blockSize like this:

```
demoFile->DO_blockSize = -( fileSize - 32 );
```

The object size itself is calculated in a similar way. Object size should include all data from the type and id fields, to the end of your song. Because this is a 16 bit field there is therefore a 64K maximum size for demo objects.

The tempo field (DS_tempo) is a precalculated clock increment providing the initial tempo of the song. This is a 32 bit field which is added to the Demo clock every 2 milliseconds. The Demo clock counts off 1/480 of a quarter note times, with a 16 bit fraction. Your program can calculate the clock increment like this:

```
myDemo->DS_tempo = (long) bpm * (long) 1048;
```

Where bpm is the desired "beats per minute" for your song. If you are working from the MIDI file's "microseconds per beat" value the formula becomes:

```
myDemo->DS_tempo = (60000000/μspb) * (long) 1048;
```

Following the song header, comes the name field. This name may be any length (up to 64 chars) and must be terminated with a 0. The MIDI File song data starts on the next even address after that.

For more information on the MIDI Standard File format, contact the International MIDI Association (IMA).

Section XII

12.5 K1200 Programs and Their Controllable Effects

#	Name	Effect	Control Source
201	Grand Piano	Vibrato	M Wheel
202	Hardstrike Piano	Vibrato	M Wheel
203	Ster Extnd Piano	Vibrato	M Wheel
204	Ballad Piano	Strings Enable	M Wheel
		Crossfade	Attack velocity
205	Studio Piano 2	Vibrato	M Wheel
206	Honky Tonk Piano	Vibrato	M Wheel
207	Piano & Slow Str	None	
208	Dual E Piano	Vibrato	M Wheel
209	Xfade E Piano	Vibrato	M Wheel
210	Chorused E Piano	Chorus depth	M Wheel
211	Fluid E Piano	Tremolo	M Wheel
212	St Trem E Piano	Tremolo rate	M Wheel
213	Grand & Electric	Piano balance	M Wheel
214	Stereo RockPiano	Vibrato	M Wheel
215	FuzzE Piano	Chorus depth	M Wheel
216	E Pno w/ Bell	Tremolo	M Wheel
		Strings Enable	Breath
217	E Piano Pad	Tremolo	M Wheel
		Strings/Choir	VTrig at f
218	E Pno & PopFlute	Tremolo	Breath
219	Br Bass/E Pno	Piano Tremolo	M Wheel
220	Steel String Gtr	Vibrato	M Wheel
221	Acous 12 String	Vibrato	M Wheel
222	Chorused Guitar	Tremolo	M Wheel
		Percussive attack	Breath
223	12 String&String	Vibrato	M Wheel
224	BassPianoGuitar	Vibrato	M Wheel
225	Delay Dulcimer	Space Trem	M Wheel
226	Acoustic Bass	Vibrato	M Wheel, M Press
227	Brt A Bass%Piano	Bass vibrato	M Wheel
228	Touch Ac Bass	Drift sharp	Attack velocity
		Drift flat	M Wheel, M Press
229	Dual Bass	Vibrato	M Wheel
230	Yes Bass	Vibrato	M Wheel
		No slap	Chan St (legato play)
231	Water Bass	Vibrato	M Wheel
232	Ostinato Bass	Vibrato	M Wheel
233	Wah Bass	Envelope control	M Wheel
234	Distorted Mutes	Chorus	M Wheel
235	Dist Mutes 5ths	Alternate attack	Attack velocity
236	Lead Guitar 1	Vibrato	M Wheel, M Press
237	Echo Guitar	Vibrato	M Wheel, M Press
		Echo rate	Breath

K1200 Programs

#	Name	Effect	Control Source
238	Clean Kit 1	Release control	M Wheel
239	Gate Rock Drm	None	
240	Big Kick&Snare	Release control	M Wheel
241	Kit w/RvsCymbal	Release control	M Wheel
242	GateEcho 76 Kit	Echo volume	M Wheel
243	Monster Rock Drm	None	
244	16 Kit/Roll/Perc	None*	
245	Rap Kit	Release control	M Wheel
246	Drums & Congas	Release control	M Wheel
247	Gated Congas	Reverb balance	M Wheel
248	Perc Ensemble	Release control	M Wheel
249	Metalfest	None	
250	CaveTribe	None	
251	Tappy Triangle	Tremolo	M Wheel
252	Echo Marimba	Echo transpose	M Wheel, Breath
253	Guitar & Synth	Vibrato	M Wheel, M Press
254	Klavinyet	Growl vibrato	M Wheel
255	HydroKlav	None	
256	Synth Hrpschrd	Vibrato	M Wheel
		Tremolo	Breath
257	Synth Banjo	Attack timbre	M Wheel
258	Synth Kalimba	Tremolo	M Wheel
259	Synth Pizz 1	None	
260	Canyon Horns	Choppy Tremolo	M Wheel
261	Plucksynth 1	Pitch envelope	M Wheel
262	Tootsynth	Pitch envelope	M Wheel
263	Ringers	Tremolo	M Wheel
264	Plucked Flute	Tremolo	M Wheel
		Pitch envelope	Breath
265	Just Like a Mini	Vibrato	M Wheel, M Press
266	aMaysing Flute	Pitch envelope	M Wheel
267	Gooshy Lead	Release control	M Wheel
268	Dyn Analog Lead	Vibrato	M Wheel, M Press
		Brightness	Attack velocity
269	Jungle Flute	Release control	M Wheel
270	Alien Voice Lead	Echo rate	M Wheel
		Vibrato	M Press, Breath
271	Synth Bass Lead	Vibrato	M Wheel, M Press
272	Guitar Wave Lead	Vibrato	M Wheel, M Press
		Brightness	Attack velocity
273	Bells w/ Echo	Tremolo	M Wheel
274	Tingle Things	Pitch envelope	Breath
275	New Age Piano	Tremolo	M Wheel
276	Space Filter	Sweep envelope	M Wheel

Section XII

K1200 Programs

#	Name	Effect	Control Source
277	Resonance Man	Sweep envelope Vibrato	Attack velocity M Wheel, M Press
278	PrsAnalogTrumpet	Vibrato	M Wheel, M Press
279	Analog Brass	Vibrato Pitch envelope	M Press M Press
280	Fusion Brass	Vibrato Add fourth	M Press M Wheel
281	Fat Synth	Choppy tremolo	M Wheel
282	Wood 'n Air	Underwater Tremolo	M Wheel
283	HybridSynthbrass	Tremolo	M Wheel
284	Syn Brass & Str	Brass envelope control	M Wheel
285	SynthOrchestra	Tremolo	M Wheel
286	Synth Strings	Vibrato	M Wheel, M Press
287	Grand Strings	Envelope control	M Wheel
288	Koto Orch	None	
289	Fast Strings	Release control	M Wheel
290	Slow Strings	<i>sfz</i>	M Wheel
291	Vel&Prs Strings	Attack control Swell	Attack velocity M Press
292	Tremolando	<i>sfz</i> decrescendo tremolo Tremolo rate	VTrig at <i>f</i> M Wheel
293	Slapback Strings	Tremolo	M Wheel
294	Stereo SloString	Brightness	Attack velocity
295	Bell & String	Tremolo	M Wheel
296	Plucked Harp	Vibrato	M Wheel
297	Andreas	Strings enable	M Wheel
298	Bright Marimba	Soft mallet	M Wheel
299	Gogo Marimba	None	
300	(No Program Assigned)		
301	FluidPluckMarmba	Piano enable	M Wheel
302	New Age Marimba	Soft mallet	M Wheel
303	Vibes	Tremolo	M Wheel
304	Fluid Vibes	Tremolo	M Wheel
305	Ster Trem Vibes	Tremolo rate	M Wheel
306	ABass+Ride%Vibes	Ride disable Tremolo rate & depth	Breath M Wheel
307	Steel Drums	None	
308	Choir	None	
309	Fast Choir	Vibrato	M Wheel
310	Cathedral Choir	Slow stereo tremolo	M Wheel
311	Bell & Choir	Tremolo	M Wheel
312	Hybrid Voices	Tremolo	M Wheel
313	Tenor Sax	Vibrato Balance control	M Wheel, M Press P Wheel

K1200 Programs

#	Name	Effect	Control Source
314	Prs Growl Tenor	Growl	M Wheel, M Press
315	Mel Room Sax	None	
316	PrsBrtTenorSax	Vibrato	M Wheel
		Brightness	M Press
317	Flute	Tremolo	M Wheel, M Press
318	Reverb Flute	Tremolo	M Wheel, M Press
		Alternate attack	Sustain
319	Wendy's Flute	Tremolo depth	Inverse Attack velocity
320	Echoplex Flute	Tremolo	M Wheel, M Press
		Alternate attack	Sustain
		Echo rate	Breath
321	Bamboo Flute	Echo rate	M Wheel
322	Clarinet	Vibrato	M Wheel
323	Chamber Band	Woodwind solo	M Wheel
		Brass solo	Breath
324	Prs Big Band	Swell	M Wheel, M Press
325	Horn Section	Attack control	Attack velocity
326	Solo Trumpet	Reverb disable	M Wheel
		Brightness	Attack velocity
		Balance control	P Wheel
327	Prs Vib Trumpet	Vibrato	M Wheel, M Press
		Brightness	Attack velocity
328	Prs LeadTrumpets	Swell	M Wheel, M Press
329	Baritone Horn	Vibrato	M Wheel
330	Warm Organ	Tremolo	M Wheel, M Press
331	Electric Organ	Leslie switch	M Wheel
332	Organ w/ Preslie	Leslie	M Press
333	Drawbars 2	Drawbars	M Wheel
334	Full Stops	Leslie switch	M Wheel
335	Clav Organ 2	Leslie	M Wheel
336	Piano & Organ 2	Vibrato	M Wheel, M Press
337	DynamicOrchestra	Vibrato	M Wheel
338	Fluid Piano	Vibrato	M Wheel
		Strings enable	VTrig at <i>ff</i>
339	Orchestra 2	Brass balance	M Wheel
340	String&Choir Pad	Vibrato	M Wheel
341	Flootz	Brightness	M Wheel, M Press
342	Slow Vibes	Space tremolo	M Wheel
343	Triangle Strings	Triangle sizzle	M Wheel
344	Q Orchestra	None	
345	Nuageux	None	
346	Slow Guitars	Tremolo rate	M Wheel
347	Long Horns	None	
348	Texture Synth	Tremolo	M Wheel
349	Breath Pad	Brightness	M Wheel, M Press
350	Slow Reed Pad	Vibrato	M Wheel

Section XII

K1200 Programs

#	Name	Effect	Control Source
351	Dark Phazer	Release control	M Wheel
352	Krellian Falls	None	
353	Crickets	Temperature	Key number
354	SISTER SHIP	Watch out!	
355	Clockworks	None	
356	Klaus	Doubling	M Wheel
357	Ecoplecks	Echo rate	M Wheel
		Freeze	Sustain
358	Surf/ Seagulls	None	
359	Sub Mergence	None	
360	Bats Away	Modulation rate	M Wheel
361	Slow Cymbals	Vibrato	M Wheel
362	Alien War	None	
363	TuningNote/Click	Sine wave	M Wheel
		Balance	Breath
		Clicks	C# 6 and up

K1200 Soundfiles—in the order they appear in the Soundfile list.

1/1 indicates normal semitone pitch intervals between key numbers. 1/2 indicates quartertone intervals, and 1/4 indicates eighth-tone intervals.

Grand Piano	Bright Strings	Bright Trumpet
Strings	Mellow Strings	Mellow Trumpet
Choir	Extended Dynamic Strings	Extended Dynamic Trumpet
Acoustic Bass	Bright Choir	Organ II
Vibes	Very Bright Choir	Electric Piano Wave
Baritone Horn	Mellow Choir	Clav Wave
Clarinet	Very Mellow Choir	Horn Wave
Trumpet	Extended Dynamic Choir	Bell Wave
Organ I	Bright Acoustic Bass	Harpsichord Wave
Bright Piano	Bright Vibes	Sine Wave
Very Bright Piano	Mellow Vibes	Sawtooth Wave
Mellow Piano	Extended Dynamic Vibes	Dull Sawtooth Wave
Hard Strike Piano	Bright Baritone Horn	Alias Sawtooth Wave
Soft Strike Piano	Mellow Baritone Horn	Square Wave
Extended Dynamic Piano	Bright Clarinet	Alias Square Wave
Extended Dynamic Piano 2	Mellow Clarinet	Ah Wave
Alien Piano	Extended Dynamic Clarinet	

K1200 Soundfiles

123 Wave
4567 Wave
89101112 Wave
HiFrq Formant
Flat Spectrum
1/3 Wide Pulse
Very Dull Sawtooth
Slightly Dull Sawtooth
Slightly Dull Square
Sine Wave +
Sine Wave ++
Sine Wave +++

123 Wave +
123 Wave ++
Very Dull Sawtooth +
Very Dull Sawtooth ++
Slightly Dull Sawtooth +
Slightly Dull Square +
Slightly Dull Square +++
Third Wave +
Third Wave +++

Distorted Guitar Wave
Bright Distorted Guitar Wave
Mellow Distorted Guitar Wave
Extended Dyn. Dist. Guitar Wave

Flute
Bright Flute
Mellow Flute
Dual Electric Piano
Soft Electric Piano
Hard Electric Piano
Electric Bass
Slap Bass
Dual Electric Bass
Bright Electric Bass
Very Bright Electric Bass
Mellow Electric Bass
Bright Slap Bass
Mellow Slap Bass
Clean Kit 1 (Drums)
Clean Kit 2
Clean Kit 3
Clean Kit 4

Process Kit 1
Process Kit 88
Drums & Percussion 88
5-Octave Drums
2-Octave Drums
4-Octave Congas
Congas
Open Congas
Conga Slaps
55-Gallon Drums
1/2 Pint Drum

Cymbals
Perc Ensemble
Rap Drums
Triangle 1/2
Shaker 1/2
Tambourine 1/2
Tambourine Shake 1/2
Agogo Bell 1/2
Agogo Mute 1/2
Clave 1/2
Marimblock 1/2
Cabasa 1/2
Guiro 1/2
Uppuiro 1/2
Toms 1/2
Triangle 1/1
Agogos 1/1
Guiros 1/1
Marimba
Bright Marimba
Mellow Marimba
Extended Dynamic Marimba
Steel String Guitar
Bright Steel String Guitar
Mellow Steel String Guitar
Quiktar
Plucked Harp
Tenor Sax
Bright Tenor Sax
Mellow Tenor Sax
Extended Dynamic Tenor Sax
Distorted Mutes
Bright Distorted Mutes
Mellow Distorted Mutes

High Noise
Medium Noise
Low Noise
Very Low Noise
Noise 1/4 Tr
Noise 1/2 Tr
Noise 1/1 Tr
High Thump
Medium Thump
Low Thump
Very Low Thump
Thump 1/4 Tr
Thump 1/2 Tr
Thump 1/1 Tr

Section XII

12.6 Audio Outputs

Like most musical instruments, the K1200 features unbalanced audio outputs. The nominal output signal level is -14 dBV, a compromise chosen to be compatible with both line-level consumer equipment and instrument amplifiers. With a maximum output signal level of +17 dBV, the K1200 has sufficient capability to drive most audio equipment to full power, but gain should be added (usually at the mix console input stage) when the unit is used in +4 dBm systems. The recommended load impedance for the K1200's outputs is 10 kohms; do not connect it to 600 ohm (actual low-Z) inputs.

Since it employs a 16-bit floating point sampling process, the K1200 is capable of very high audio quality. Care must be taken with the audio connections, particularly in recording applications, in order to preserve the inherent high fidelity of the Kurzweil samples.

12.6.1 Choosing Cables

Where the sound system input accommodates phone jacks, the K1200 may be connected using guitar-type cables. Straight (rather than coiled) cords are preferred. Use only high-quality cables with good shielding and sufficient flexibility. Gold or MIL-spec brass connectors, if available, will provide the best long-term performance.

When making cables, choose highly flexible, rubber-jacketed cable with braided shielding (foil shielding is acceptable in fixed installations where the cables will not be handled or flexed). To minimize internal self-capacitance, use single-conductor (*not* dual-conductor) shielded cable.

12.6.2 Audio Connector Wiring

Figure 12-4 (next page) illustrates wiring practices for phone, RCA and XLR type connectors.

In the case of XLR connectors at balanced inputs, there is no clear standard for pin assignments: while many now advocate pin 2 "hot," a large proportion of professional audio equipment is pin 3 "hot." Depending upon the input circuit design, the choice may make virtually no difference in sound quality and signal level, but we can't guarantee that this will be the case. The best approach is to consult and follow the recommendations in the equipment's instruction manual.

The proper method for handling the unused pin at the balanced input similarly may vary dependent upon input circuit design. Some equipment will require that the unused pin be grounded; for other components, it may not matter. Again, check the instruction manual.

12.6.3 Use of Direct Boxes

Both in the studio and in touring performance, some form of isolation may be required at the K1200 output to control induced noise and hum. The most common solution is to use a "direct box."

The quality of different direct boxes varies from reasonable to downright awful, however. Many direct boxes are not designed to handle the higher signal level and broad frequency range of the K1200. With such units, you will hear a very noticeable degradation in sound quality when the box is inserted in line. Particularly in recording applications, this is usually unacceptable.

To preserve the sonic fidelity of the K1200, it is extremely important to select a high-quality direct box which is designed for line-level isolation.

For best performance in recording, in fact, a better solution is to simply use a good line transformer (10 k : 10 k), preferably with dual Faraday shields.

K1200 Output Connection:

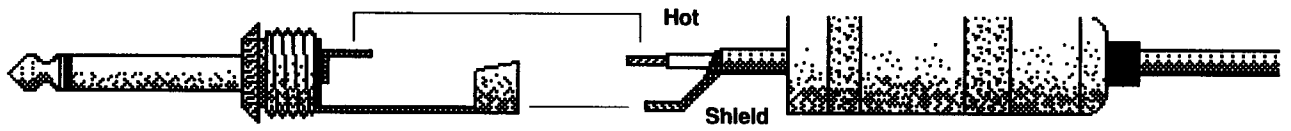

System Input Connection:

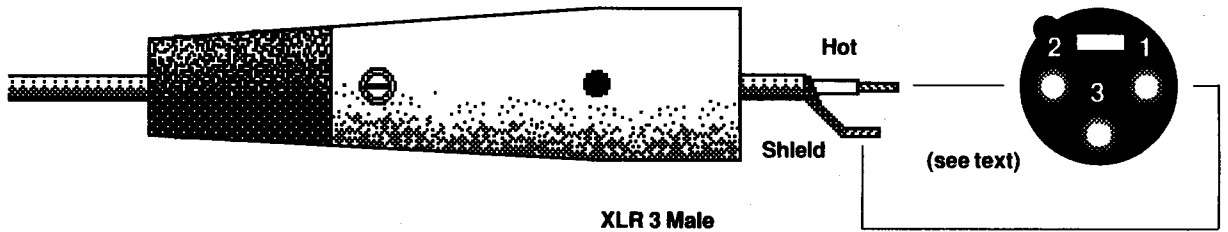
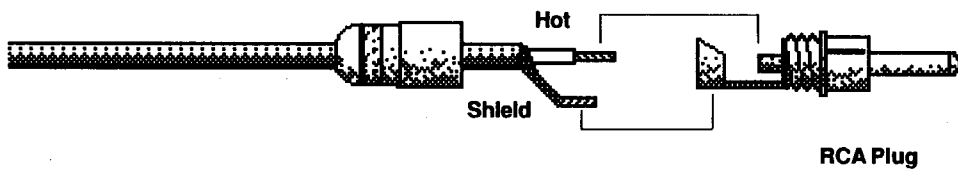
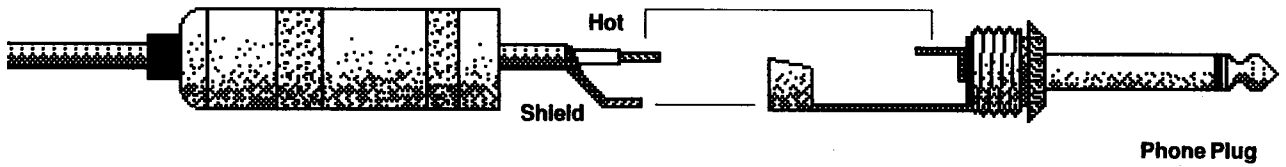

Figure 12-4 Audio Connector Wiring

Section XII

12.7 Specifications

K12000

Description	MIDI-controllable, 24-note polyphonic, multitimbral digital sample player and programmable wavetable synthesizer
Keyboard	88 keys, weighted action, spring return, with monophonic aftertouch
Program Memory	
Factory Presets	ROM (Read Only Memory), 162 presets
User-Programmable	48 kbyte RAM (Random Access Memory)
RAM Battery Backup	Lithium battery, 3 – 5 years life expectancy
Audio Outputs	
Type	Stereo, unbalanced
Connectors	1/4-inch tip/sleeve phone jack (x 2)
Nominal Output Level	-14 dBV
Maximum Output Level	+17 dBV
Impedance	100
Recommended Load Impedance	10 k minimum
Output Noise	-86 dBV typical
MIDI Connections	
Type	In, Out, Thru
Connector	Standard DIN 5-pin
Accessories (included)	Two foot switches
Power Requirements	
Voltage	100 – 120 VAC, 50/60 Hz 200 – 240 VAC field-selectable
Power Consumption	40 Watts
Mains Protection	AGC 1 Amp, 125 Volt fuse
Physical Dimensions	54 3/4" W x 14 1/4" H x 5 1/2" D
Shipping Weight	65 lbs. (30 kg)

External Dimensions

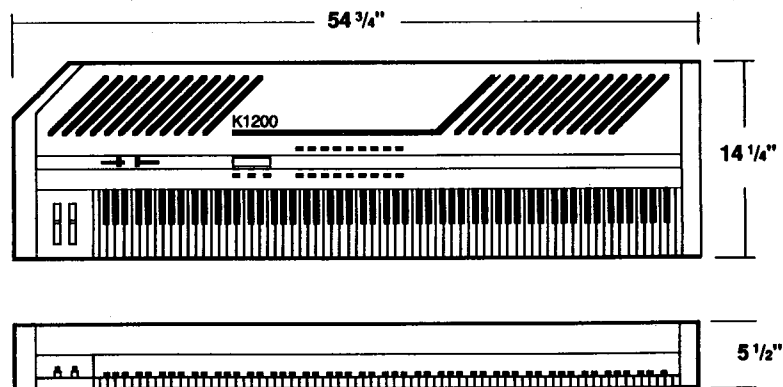

MIDI Implementation Chart

Manufacturer:
Kurzweil Music Systems, Inc. /
Young Chang Akki Co. Ltd.

Dated: 11/20/89
Version: 1.0

Digital Synthesizers

Model: K1200

FUNCTION		TRANSMITTED	RECOGNIZED	REMARKS
Basic Channel	Default	1	1	Memorized
	Changed	1 - 16	1 - 16	
Mode	Default	Mode 1	Mode 1	Memorized *
	Messages	Mode 1 & 3	Mode 1 & 3	
	Altered			
Note Number			0 - 127	Key range: C0 - C8
	True Voice	12 - 120	12 - 120	
Velocity	Note ON	O	O	
	Note OFF	O	O	
After Touch	Keys	X	O	
	Channels	O	O	
Pitch Bender		O	O	
Control Change		O	O	Controller assignments are programmable**
		1 - 31	1 - 31	
		64 - 95	33 - 63 64 - 95	
Program Change		O	O	May be mapped to 0 - 999
	True #	0 - 99	0 - 127 1 - 128	
System Exclusive		O	O***	
System Common	Song Pos.	X	X	
	Song Sel.	X	X	
	Tune	X	X	
System Real Time	Clock	X	X	
	Messages	X	X	
Aux Messages	Local Control	X	O	
	All Notes Off	X	O	
	Active Sense	X	O	
	Reset	X	X	

Notes

* Use MULT Mode to assign different Programs to each MIDI channel.

** Bi-directional mod wheel, two switch pedals

*** Manufacturer's ID = 07. Device ID: default = 0; programmable 0 - 126

O = Yes
X = No

Mode 1: Omni On, Poly
Mode 2: Omni On, Mono
Mode 3: Omni Off, Poly
Mode 4: Omni Off, Mono

Section XIII

I N D E X

A

AC Power Adapters	8
ASRs	94
Absolute Mod Wheel	44
Absolute Pitch Wheel	44
Advanced Editing	36
Aftertouch	42
Alphabetic Buttons	6
All Notes Off	18, 23, 54
Amplifiers	10
Amplitude control	107
Amplitude Envelope	98
Attack Level	100
Attack Segment	98
Attack Time	100
Attack Velocity	43
Audio Connections	10
Audio Output Jacks	7, 10
Automatic Demo	13

B

Balance	87
Basic Editing	25
Basic MIDI channel	21, 53

Bin Banks

Selecting Objects	15
Storing Objects	15

Bin Maps

Selecting	17, 49
Edit	49, 71

Buttons

6

C

Cables

Audio	9
MIDI	9
Power	9

Calibrations

Foot Pedals	68
Pitch and Mod Wheels	6

Chain Link	56
Change Effects Level	84
Channel Editing	59
Channel State	44
Channel Stealing	55
Chorus	111
Compare Function	28
Compiled Effects	25, 31, 119
Confirmation	27, 56
Connections	8
Control Source List	40, 120

Control Sources

Bipolar	40
Configuration	40
Description	40
Global	40
Local	40
Logical	40
Unipolar	40

Controls	5
----------	---

D

Damage from shipping	2
Data Slider	68
Deassigning Channels	21
Default Control Sources	59, 67
Delay	84
Delete Programs	57
Delete Song	13, 57
Demo Feature	13
Demo File Converter	14
DEMO Object Format	136
DEMO Objects	14
Diagnostics	131
Disabling Channels	21
Display	6
Dual Press	14
Dump Master	57
Dump Memory	57

Dump Program 57
 Dynamic range Adjustment 55

H

Hard Reset 23, 58
 Home Stereos 11

E

Editing via MIDI 56
 Edit Default Control Sources 59, 67
 Edit MIDI Channels 46, 59

I

EDIT Mode
 Entering 28
 Menus 39

Ignore All Notes Off 54
 Inspection of new unit 2

Edit Bin Map 71
 Edit Intonation Table 52, 65
 Edit Performance Setup 72
 Edit Pressure Map 49, 58, 66
 Edit Program List 49, 69
 Edit Velocity Map 48, 58, 62
 Effects 5, 25, 31
 Effects Level 85
 Enable Layer 85
 Envelope 2 103
 Envelope Control 104
 Exploring Programs 14
 Extended Program Changes 48

Intonation Reference Key 52

Intonation Table
 Selecting 51
 Edit 52, 65

Introduction
 Basic Editing 25
 Performance Guide 2
 Programming Reference 38
 Programming Tutorial 108

Inverse Attack Velocity 43
 Inverse Release Velocity 43
 Inverters 97

F

FCC Verification Inside Front Cover
 Foot Pedals 68, 76
 Foot Pedal Jacks 7
 Freeze Pedal 85
 Front panel 5
 Fuse 3
 Fuse Rating 7

K

Keyboard Tilt 83
 Key Number 43
 Key State 43

G

Global ASRs 94
 Global LFOs 93

L

LCD 6
 LFOs 92
 LFO Phase 44

Layer Menu 81, 125
 Layered Programs 29

Section XIII

Layers	5, 25	Mono Pressure Transmit Mode	68
Cleaning	81	Multi Mode	20
Creating	30		
Delete	83	N	
Duplicate	81		
Enable	85	Name	32
Import	29	Negators	97
Leslie Effect	112	Note State	43
Local Control	59	Numeric Buttons	6
M		O	
Master Dump	57	ObjectMover™	13
Master Menu	46, 123	Objects	16, 38
Master Stealer	55	Omni Mode	20
Master Transposition	53	Output Level	12
Master Tune	53		
Memory Dump	57	P	
Menus	27, 39		
MIDI		Pan	88
Basic Channel	21, 53	Parameter Headings	45
Chain Link	56	Parameters	25
Channels, deassigning	21	Patch Thru	23
Channels, disabling	21	Pedals	68, 76
Channel Selection	16	Pedal Jacks	7
Connections	19	Performance Guide	1
Control Numbers	122		
Dump Commands	57	Performance Setup (PSetup)	16
Editing	56	And MIDI	115
Loops	23	Default Control Sources	59, 67
Modes	20	Edit	59, 72
Overview	18	Selecting Regions	17
Program Change Messages	18		
Reference Key	53	Phasing	25
Sequencing	19	Pitch Bend Range	54
		Pitch Control	105
MIDIScope	22	Pitch Wheel	42, 76
Mixers	96	Playback Rate	44
Mixing Consoles	11, 12	PLAY Mode Shortcuts	16
Modular Effects	25, 90	Play Thru	23
Modulation Wheel (Mod Wheel)	6, 68, 76	Polyphonic Pressure	42
Modules	90	Poly Mode	20
Monophonic Audio Output	36, 53	Power Connection	8
Mono Pressure	42		

Power surges	10
Precautions	3

Pressure Maps	
Edit	49, 66
Receive	48
Transmit	58

Pressure Response	55
Program Change Messages (MIDI)	18
Program Change Messages (Extended)	48
Program Dump	57
Program List (PList)	49 - 51, 69
Program List Editing	69
Program Menu	79, 124
Programming Reference	36
Programming Tutorial	108
Programs	
Naming	32
Saving	35
Selection	14, 16
Structure	4

R

Rear Panel	7
Receive Program Change	46
Receive Pressure Map	48
Receive Velocity Map	48
Reference Section	118
Regions (PSetups)	17
Region Modes	74
Release Level	102
Release Segment	102
Release Time	102
Release Velocity	43
Reset	22, 58
Reset MIDI Channels	46
Roland Products	23

S

Save	35
Selecting Programs	14, 16
Self-Diagnostics	131
Setting Split Points	17
Setting Transposition	17
Shipping Damage	2
Shortcuts in PLAY Mode	16
Software Version	56
Soft Reset	23
Soft Thru	23
Songs	13
Sostenuto Pedal	85
Soundfile	5
Split Points	17, 77
Split Programs	5, 29
Stealer	55
Stereo Pan	88
Storing Objects to Bin Banks	15

Submenus

Bin Map Editor	71
Channel Editor	59
Default Control Sources Editor	67
Intonation Table Editor	65
Performance Seupt Editor	72
Pressure Map Editor	66
Program List Editor	69
Velocity Map Editor	62
Sustain Pedal	85
Sustain Problems	23
Switch Pedals	68, 76
Switch Pedal Jacks	7
System Exclusive ID	56
System Exclusive Messages	132

Section XIII

T

Transmit Pressure Map	58
Transmit Program Change	46
Transmit Velocity Map	58
Transposition	17, 53
Tremolo	110
Troubleshooting	12, 23
Tune 53	

V

Values	25
Velocity Maps	
Edit	48, 62
Receive	48
Transmit	58
Velocity Trigger	88, 114
Vibrato	109
Voltage Adjustment Switch	8
Voltage Requirements	3
Volume adjustment	12

Kurzweil 1200 Pro I Program Lists: Library I and Library II

Acoustic Piano

- 201 Grand Piano
- 202 Hardstrike Piano
- 203 Sier Exrtd Piano
- 204 Ballad Piano
- 205 Studio Piano 2
- 206 Honky Tonk Piano
- 207 Piano & Slow Str

Electric Piano

- 208 Dual E Piano
- 209 Xiade E Piano
- 210 Chorused E Piano
- 211 Fluid E Piano
- 212 St Trem E Piano
- 213 Grand & Electric
- 214 Stereo Rock Piano
- 215 FuzzE Piano
- 216 E Pno w/ Bell
- 217 E Piano Pad
- 218 E Pno & PopFlute
- 219 Br Bass/E Pno

Acoustic Guitar

- 220 Steel String Gtr
- 221 Acous 12 String
- 222 Chorused Guitar
- 223 12 String&Siring
- 224 BassPianoGuitar
- 225 Delay Dulcimer
- 226 Acoustic Bass
- 227 Br A Bass%/Piano
- 228 Touch Ac Bass

Electric Bass

- 229 Dual Bass
- 230 Yes Bass
- 231 Water Bass
- 232 Ostinato Bass
- 233 Wah Bass

Electric Guitar

- 234 Distorted Mules
- 235 Dist Mutes 5ths
- 236 Lead Guitar 1
- 237 Echo Guitar

Drum Kit

- 238 Clean Kit 1
- 239 Gate Rock Drm
- 240 Big Kick&Snare
- 241 Kit w/RvsCymbal
- 242 GateEcho 76 Kit
- 243 Monster Rock Drm
- 244 16 Kit/Roll/Perc
- 245 Rap Kit
- 246 Drums & Congas

Percussion Battery

- 247 Gated Congas
- 248 Perc Ensemble
- 249 Metalfest
- 250 Cave Tribe
- 251 Tappy Triangle
- 252 Echo Marimba

Synth Clavs

- 253 Guitar & Synth
- 254 Klavinyel
- 255 HydroKlav

Percussive Synths

- 256 Synth Hrpschrd
- 257 Synth Banjo
- 258 Synth Kalimba
- 259 Synth Pizz 1
- 260 Canyon Horns
- 261 Plucksynth 1
- 262 Toolsynth
- 263 Ringers
- 264 Plucked Flute

Lead Synths

- 265 Just Like a Mini
- 266 aMaysing Flute
- 267 Gooshy Lead
- 268 Dyn Analog Lead
- 269 Jungle Flute
- 270 Alien Voice Lead
- 271 Synth Bass Lead
- 272 Guitar Wave Lead

Synth Bells

- 273 Bells w/ Echo
- 274 Tingle Things
- 275 New Age Piano

Synth Brass

- 276 Space Filter
- 277 Resonance Man
- 278 PrsAnalogTrumpet
- 279 Analog Brass
- 280 Fusion Brass
- 281 Fat Synth
- 282 Wood'n Air
- 283 HybridSynthbrass

Synth Strings

- 284 Syn Brass & Str
- 285 SynthOrchestra
- 286 Synth Strings
- 287 Grand Strings
- 288 Koto Orch

Orchestral Strings

- 289 Fast Strings
- 290 Slow Strings
- 291 Vel&Prs Strings
- 292 Tremolando

Pop Strings

- 293 Slapback Strings
- 294 Stereo SloString
- 295 Bell & String

Plucked Harp

- 296 Plucked Harp
- 297 Andreas

Marimba

- 298 Bright Marimba
- 299 Gogo Marimba
- 300 (No Program Assigned)
- 301 FluidPluckMarimba
- 302 New Age Marimba

Vibraphone

- 303 Vibes
- 304 Fluid Vibes
- 305 Ster Trem Vibes
- 306 ABass+Ride%Vibes
- 307 Steel Drums

Choir

- 308 Choir
- 309 Fast Choir
- 310 Cathedral Choir
- 311 Bell & Choir
- 312 Hybrid Voices

Woodwinds

- 313 Tenor Sax
- 314 Prs Growl Tenor
- 315 Mel Room Sax
- 316 PrsBr1TenorSax
- 317 Flute
- 318 Reverb Flute
- 319 Wendy's Flute
- 320 Echoplex Flute
- 321 Bamboo Flute
- 322 Clarinet
- 323 Chamber Band

Brass

- 324 Prs Big Band
- 325 Horn Section
- 326 Solo Trumpet
- 327 Prs Vib Trumpet
- 328 Prs LeadTrumpets
- 329 Baritone Horn

Organs

- 330 Warm Organ
- 331 Electric Organ
- 332 Organ w/ Preslle
- 333 Drawbars 2
- 334 Full Stops
- 335 Clav Organ 2
- 336 Piano & Organ 2

Synth Pads

- 337 DynamicOrchestra
- 338 Fluid Piano
- 339 Orchestra 2
- 340 String&Choir Pad
- 341 Floolz
- 342 Slow Vibes
- 343 Triangle Strings
- 344 Q Orchestra
- 345 Nuageux
- 346 Slow Guitars
- 347 Long Horns
- 348 Texture Synth
- 349 Breath Pad
- 350 Slow Reed Pad
- 351 Dark Phazer

Effects

- 352 Krellian Falls
- 353 Crickets
- 354 Sister Ship
- 355 Clockworks
- 356 Klaus
- 357 Ecopiecks
- 358 Surf/ Seagulls
- 359 Sub Mergence
- 360 Bats Away
- 361 Slow Cymbals
- 362 Alien War

Utility

- 363 TuningNote/Click

The first digit of each program Number is the list identifier: the 200s make up the PList "Library I" and the 300s make up list "Library II."

The second 2 digits give the exact MIDI program # of the program. The order of these lists is consistent with the internal order you see when editing Plists or using ObjectMover™.

Edited Programs are saved in RAM, with PROG IDs beginning at 255 and numbered downward. They are automatically given Program numbers in the 400s range, and appear in the PList called "RAM Progs". These numbers can be reassigned.

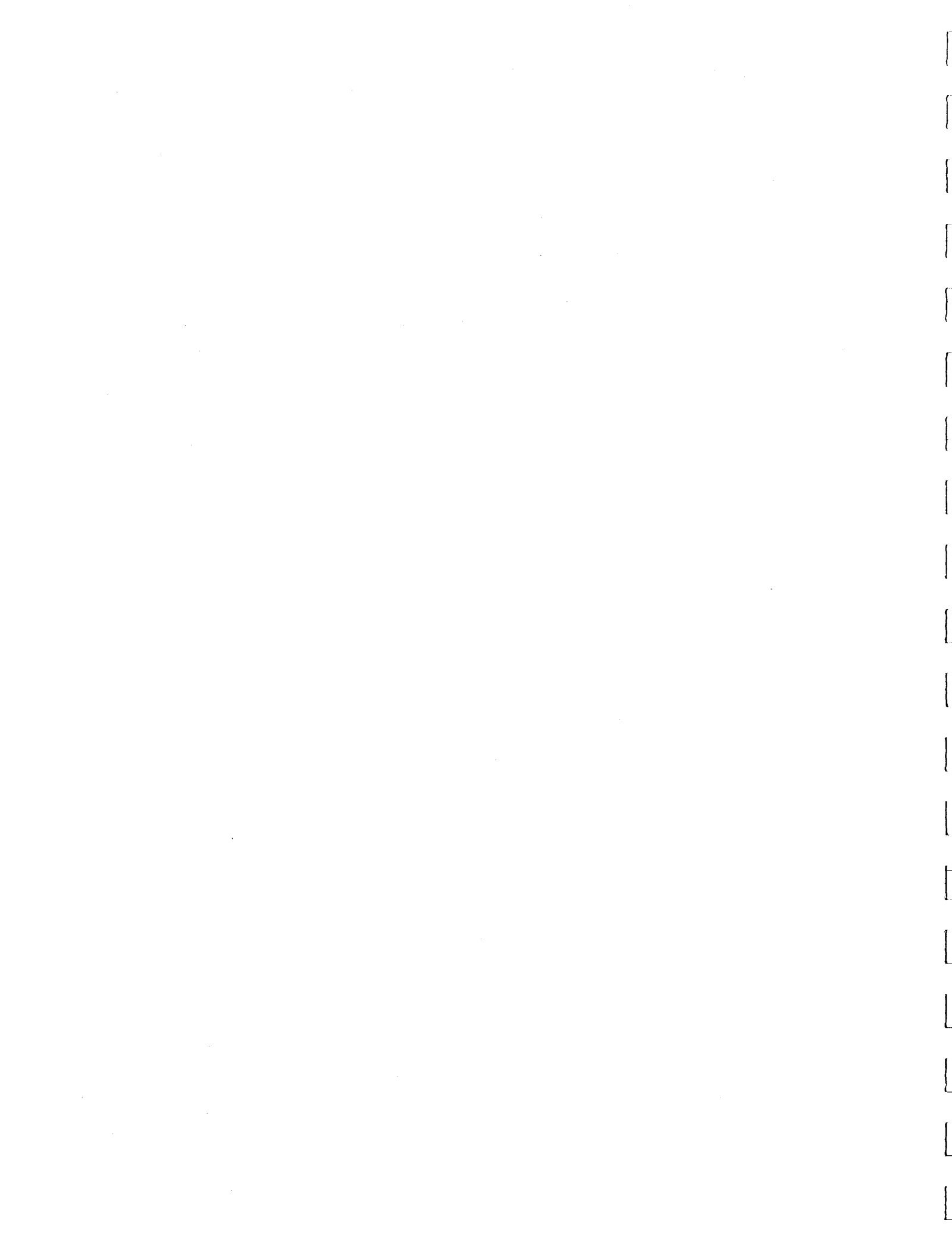

Kurzweil 1200 Pro II Program Lists: Library I and Library II

Solo Violin

- 201 Orch Solo Violin
- 202 Solo Violin 2
- 203 Slow Violin
- 204 Fast Legato Vin
- 205 Prs Solo Vin
- 206 Electric Violin
- 207 Echoplex E Vin

Solo Cello

- 208 Orch Solo Cello
- 209 Solo Cello
- 210 Fast/Legato/Cello
- 211 Prs Solo Cello

String Ensemble

- 212 SoloStr-Herminics
- 213 Hall Cel/Vln 1
- 214 String Section 2
- 215 Chamber Orch
- 216 Cello / Slo Str
- 217 Slo Str / Violin

Orchestral Strings

- 218 Bowed Strings
- 219 Medium Strings
- 220 Slow Strings
- 221 Attack C# Strings
- 222 Stereo SloString
- 223 Strings Sloclave
- 224 Triple Strings
- 225 Flanged Strings
- 226 Bright Strings
- 227 Hrd Atk Strings
- 228 Pizzicato Strings
- 229 Underwater Pizz
- 230 Boomin' Pizz
- 231 Far Away Pizz
- 232 U-Choose-It Perc
- 233 Perc Strings
- 234 Tremolo Strings
- 235 VTrgSfz-Trem Str
- 236 Orchestra 1
- 237 SloStr&Horn/Trp

Trumpet

- 238 Open Trumpet
- 239 Open Trumpet 2
- 240 Prs LeadTrumpets
- 241 Prs Solo Trumpet
- 242 Muted Trumpet
- 243 Trumpet & Mutes

Trombone

- 244 Solo Trombone
- 245 VTrig Growl Bone
- 246 Open Trombone

Brass Sections

- 247 Prs Unison Brass
- 248 Prs BrassSection
- 249 Brass Section 2
- 250 SfzBrassPrsSwell

Tenor Sax

- 251 Solo Soft Tenor
- 252 Fast LegatoTenor
- 253 Damp Soft Tenor
- 254 Medium Tenor Sax

Brass Ensembles

- 255 Jazz Saxophone
- 256 Dual Tenor w/Vib
- 257 Prs Dual Tenor
- 258 Growl Tenor Sax
- 259 Soft & Med Tenor
- 260 Trp & SoftTen & Mut
- 261 Bone & 2 Tenors
- 262 Big Band 2
- 263 Big Band 5
- 264 JzTenor/Bonesax
- 265 VTrig Sfz Band
- 266 Prs Unison Band
- 267 Canyon Horns

String Pads

- 268 Canyon Orch
- 269 Horn Pad
- 270 Mellow Pad
- 271 Prs Sax Pad 1
- 272 Ambient Synth
- 273 Prs Synth Horns
- 274 Space Pad
- 275 Balloon Skin
- 276 Cellophone
- 277 Squeeze Box

Plucked Synths

- 278 Music Box
- 279 Synthinet
- 280 SterTrem-Harps
- 281 Syntharpsichord
- 282 Hammered E Vins
- 283 Pluck This
- 284 Trongs on Bamboo
- 285 Pluck-Horns
- 286 Nasty Analog
- 287 Click Organ
- 288 Generic Synth 1
- 289 Piztine Gurgls
- 290 Piztine Whistle
- 291 Echonest
- 292 Synth Bass Clav
- 293 Ostinato
- 294 Killer Bees
- 295 Falling Flutes
- 296 Saxocopters
- 297 Salt and Pepper

Effects

- 298 Stereo Sweep
- 299 No Prg Assigned
- 300 Resonance Man
- 301 Nuageux
- 302 Fat Synth
- 303 Water Winds
- 304 Square Pad
- 305 EPho & FatSynth
- 306 Clav Prs Synth
- 307 Prs Cook Synth
- 308 Quack Soprano

Analog Synths

- 298 Square Pad
- 299 Stereo Sweep
- 300 No Prg Assigned
- 301 Resonance Man
- 302 Nuageux
- 303 Fat Synth
- 304 Water Winds

Synth Clavs

- 305 EPho & FatSynth
- 306 Clav Prs Synth
- 307 Prs Cook Synth
- 308 Quack Soprano

Organs

- 309 Pipes
- 310 Pipes & Reeds

Synth Leads

- 311 Full Organ
- 312 Warm Organ
- 313 Like a Mini
- 314 Analog Lead
- 315 Electric Lead
- 316 Portalead

Plucked Synths

- 317 Tap Flute
- 318 Plucked Flute
- 319 Plucked Sine
- 320 Plucksynth
- 321 Plucky Bells
- 322 Tubular
- 323 Steel Drums

Synth Orchestra

- 324 Fusion Brass
- 325 Synth Orchestra
- 326 Oriental Dreams
- 327 Fade-in Strings
- 328 Flute Mallets
- 329 Sweet Horns

Alto Sax

- 330 Soft Alto Sax
- 331 Prs Soft Alto
- 332 VTrig Soft Alto
- 333 Hall Alto
- 334 Med Alto Sax
- 335 Prs Growl Alto
- 336 Solo Alto Sax

Baritone Sax

- 337 Baritone Sax
- 338 Prs Bright Bari
- 339 Dirty Bari
- 340 Solo Bari

Soprano Sax

- 341 Soprano Sax
- 342 Legato Soprano
- 343 Prs Soprano
- 344 Wah Soprano
- 345 ExtRange Prs Sax

Stabs

- 346 Brass Stabs
- 347 VTrig Stabs
- 348 Triple Stabs

Brass Sections

- 349 Soft Sax Section
- 350 Bari&Tenor/Altos
- 351 Polished Brass
- 352 Prs Big Band
- 353 SfzBand w/Bari
- 354 Space Trumpet

Flute

- 355 Flute
- 356 Legato Flute
- 357 Wendy's Flute
- 358 Orch Piccolo
- 359 Flooz
- 360 Jungle Flute
- 361 Canyon Flute

Oboe

- 362 Oboe
- 363 Orch Oboe
- 364 Press Solo Oboe
- 365 Env C# Oboe

Bassoon

- 366 Bassoon
- 367 Orch Bassoon
- 368 Prs Solo Bassoon
- 369 Ambient Bsn/Oboe

Clarinet

- 370 Clarinet
- 371 Orch Clarinet
- 372 Solo Clarinet

Woodwind ensembles

- 373 Oboe & Flute
- 374 Woodwind Splits
- 375 AKC#l Woodwinds
- 376 Cl&Bsn / Dyn Str
- 377 Bsn&FHrn/Ob&Fl

French Horn

- 378 French Horn
- 379 Orch/Dyn FHorn
- 380 Prs FHornSection
- 381 Dry FHornSection
- 382 Mello Brass Pad
- 383 Quick Horns
- 384 Caryon FHrn/ Vln Str/ Horns/Str

Timpani

- 386 Timpani
- 387 Dynamic Timpani
- 388 BassOrchTimpani

The Keyboardists' Orchestra

- 389 BaroqueOrchestra
- 390 ClassicOrchestra
- 391 Total Orchestra

Utility

- 392 TuningNote/Click

The first digit of each program Number is the list identifier: the 200s make up the PList "Library I" and the 300s make up list "Library II."

The second 2 digits give the exact MIDI program # of the program. The order of these lists is consistent with the internal order you see when editing Plists or using ObjectMover™.

Edited Programs are saved in RAM, with PROG IDs beginning at 255 and numbered downward. They are automatically given Program numbers in the 400s range, and appear in the PList called "RAM Progs". These numbers can be reassigned.

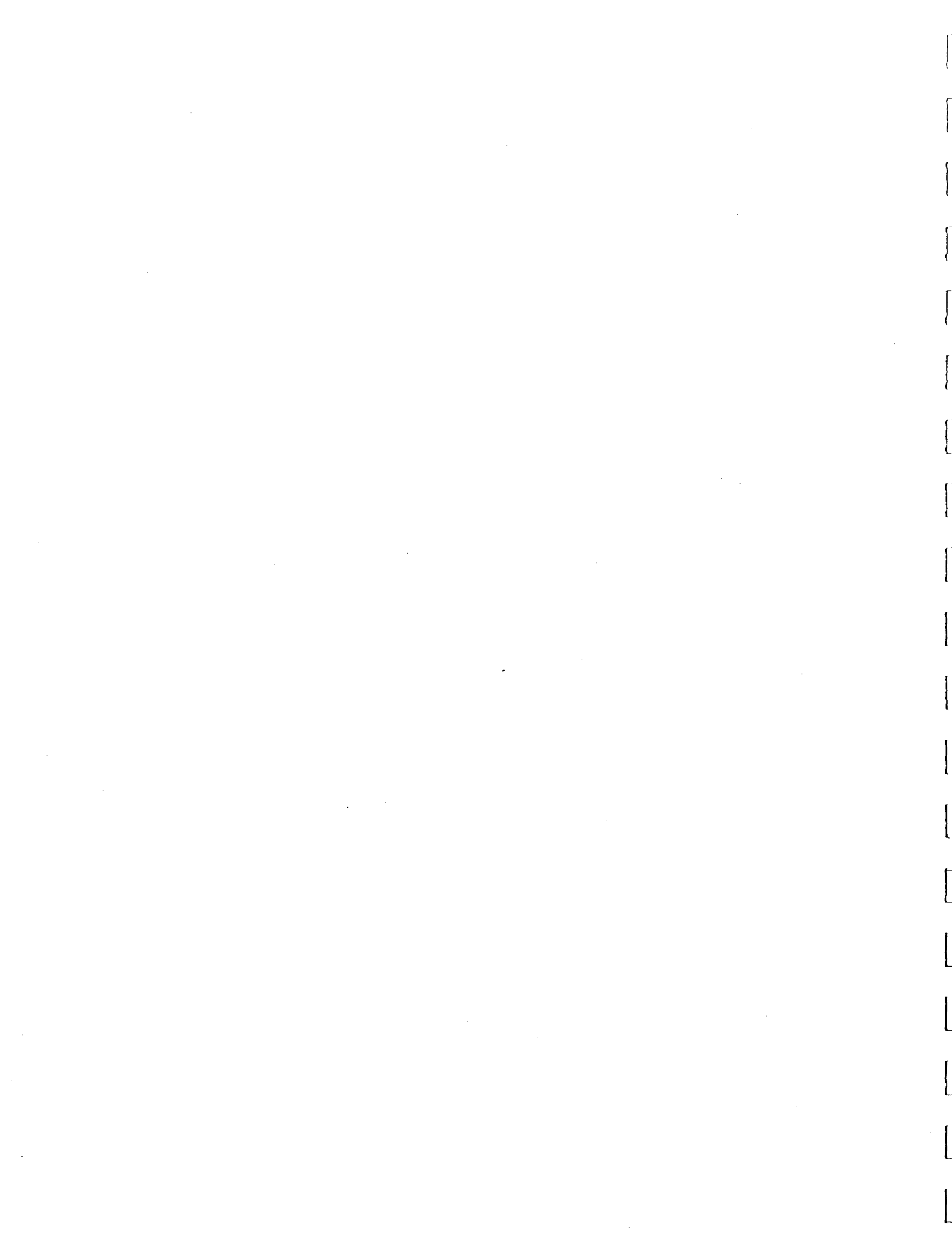

Kurzweil 1200 Pro III Program Lists: Library I and Library II

Steel String Acoustic Guitar

- 201 Steel String Gtr
- 202 Acous 12 String
- 203 Cavern Guitar
- 204 Processed Steel
- 205 Chorused Guitar
- 206 New Age Acoustic
- 207 Big Stereo Gtr

Nylon String Acoustic Guitar

- 208 Nylon String Gtr
- 209 Hard Atk Nylon
- 210 Nylon & Steel
- 211 Drifting Nylons
- 212 Watery Nylons

Hollow Body Jazz Guitar

- 213 Jazz Guitar
- 214 Wah Wah Jazz Gtr
- 215 Flanged Jazz Gtr
- 216 Jazz Guit Lead
- 217 Electric Jazz

Solid Body Electric Guitar

- 218 Clean Electric
- 219 Chorus E Guit 1
- 220 Chorus E Guit 2
- 221 Tremolo Guitar
- 222 Elec 12 String
- 223 Pedal Steel
- 224 24 St Acous-Elec

Classic Rock Guitar

- 225 Rock Guitar
- 226 Mutes
- 227 Muted Mutes
- 228 Harmonics
- 229 Rock->Harm
- 230 Mute->Rock
- 231 Compressed Rock
- 232 Guitarz
- 233 Symphonic Guitar
- 234 Fuzz Me
- 235 Press Me Fuzz Me

Acoustic Bass

- 236 Acoustic Bass
- 237 Touch Ac Bass

Electric Bass

- 238 Pick Bass
- 239 Slap Bass
- 240 Dual E Bass
- 241 Yes Bass
- 242 Ostinato Bass
- 243 Big Mouth Bass
- 244 Punchy Bass
- 245 Monster Bass
- 246 Synth Bass
- 247 Synth Fretless
- 248 Wah Bass
- 249 Water Bass

Bass Splits

- 250 E Bass/ Rock
- 251 Prs Jazz Duo
- 252 SlapBass/E Horns
- 253 Funk Duo

Baritone Saxophone

- 254 Baritone Sax
- 255 Dirty Bari
- 256 Solo Bari
- 257 AttCil Bari Sax

Tenor Saxophone

- 258 Solo Soft Tenor
- 259 Fast Legato Tenor
- 260 Medium Tenor Sax
- 261 Jazz Saxophone
- 262 Dual Tenor w/Vib
- 263 Prs Dual Tenor
- 264 Growl Tenor Sax

Alto Saxophone

- 265 Soft Alto Sax
- 266 Prs Soft Alto
- 267 Space Alto
- 268 Med Alto Sax
- 269 Prs Growl Alto
- 270 Solo Alto Sax
- 271 EnvCil Med Alto

Soprano Saxophone

- 272 Soprano Sax
- 273 Legato Soprano
- 274 Prs Soprano
- 275 Wah Soprano
- 276 ExtRange Prs Sax

Trumpet

- 277 Open Trumpet
- 278 Open Trumpet 2
- 279 Prs Solo Trumpet
- 280 Space Trumpet
- 281 Muted Trumpet
- 282 Trumpet & Mutes

Trombone

- 283 Solo Trombone
- 284 VTrig Growl Bone
- 285 Open Trombone

Brass Falls

- 286 Brass Slabs
- 287 VTrig Slabs
- 288 Triple Slabs
- 289 Stabpede

Brass Sections

- 290 Prs Lead Trumpets
- 291 Prs Unison Brass
- 292 Prs Brass Section
- 293 Brass Section 2
- 294 SizBrassPrsSwell
- 295 Soft & Med Trm
- 296 Trp & Soft Ten & Mut
- 297 Bone & 2 Tenors
- 298 Big Band 2
- 299 Big Band 5
- 300 (end of Library I)
- 300 No Prg Assigned

The Keyboardists' Big Band

- 301 VTrig Siz Band
- 302 SizBand w/Bari
- 303 Prs Big Band
- 304 Polished Brass
- 305 Soft Sax Section
- 306 Chamber Soft Saxes
- 307 Bari&Tenor/Altos
- 308 Mello Brass Pad

Synth Brass

- 309 Plucksynth a
- 310 Mello Funk Horns
- 311 Fusion Section
- 312 Fusion Band
- 313 Analog Brass
- 314 Fusion Brass

Synth Pads

- 315 Nuageux
- 316 Fade-in Sax
- 317 Sweet Steel
- 318 Sweet Horns
- 319 Resonance Man
- 320 Synth Horns
- 321 Vaguely Horns
- 322 Pseudo Strings
- 323 Sci Fi Guitar
- 324 Slow Guitars

Analog Synths

- 325 Slow Filler
- 326 Sweep
- 327 Stereo Sweep
- 328 Dark Phazer
- 329 Submerged Winds

Synth Bells

- 330 Plucked Bell
- 331 Sax o' Bells
- 332 Muflpluck Soprano
- 333 Tingle Things
- 334 Little Ballerina
- 335 Plucked Soprano
- 336 Steel Bells
- 337 Log Drums

Synth Clavs and Organs

- 338 Digital Rhodes
- 339 Perc Rhodes
- 340 Guitar & Synth
- 341 Klavinyet
- 342 Casler Clav
- 343 Synth Bass Clav
- 344 Rock Klav
- 345 Prs Bright Synth
- 346 Guitar Keys
- 347 Mute Synth Lead
- 348 Mute Synth
- 349 Dynamic Keys
- 350 Big Organ
- 351 Warm Organ

Synth Leads

- 352 Electric Sax
- 353 Just like a Mini
- 354 Analog Lead
- 355 Gooshy Lead
- 356 Space Delay
- 357 Shimmer

Hybrids

- 358 Stryngophone
- 359 Stryngophone 2
- 360 Strumpet
- 361 Sax Siring Gtr
- 362 Kungle Sax

Effects

- 363 Video Games
- 364 Lfo Phase
- 365 saxocopters
- 366 Surf/ Seagulls
- 367 Krelian Music

Utility

- 368 Tuning Note 2

