

ArtisTM

STAGE PIANO

(includes the Artis7)



Musician's Guide

KURZWEIL[®]

Part Number 910556-004 Rev. D

ArtisTM

STAGE PIANO
(includes the Artis7)

MUSICIAN'S GUIDE

KURZWEIL®

©2018 Young Chang Co., Ltd. All rights reserved. Kurzweil® is a product line of Young Chang Co., Ltd. Kurzweil®, Young Chang®, V. A. S. T.®, Artis™, and Artis7™ are trademarks of Young Chang Co., Ltd. All other trademarks and copyrights are property of their respective companies. Product features and specifications are subject to change without notice.

You may legally print up to two (2) copies of this document for personal use. Commercial use of any copies of this document is prohibited. Young Chang Co. retains ownership of all intellectual property represented by this document.

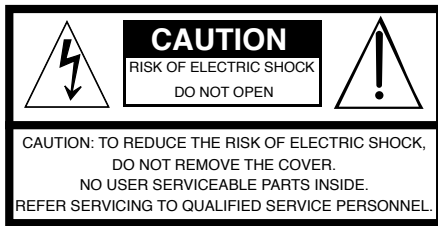

The lightning flash with the arrowhead symbol, within an equilateral triangle is intended to alert the user to the presence of uninsulated "dangerous voltage" within the product's enclosure that may be of sufficient magnitude to constitute a risk of electric shock to persons.



The exclamation point within an equilateral triangle is intended to alert the user to the presence of important operating and maintenance (servicing) instructions in the literature accompanying the product.

IMPORTANT SAFETY & INSTALLATION INSTRUCTIONS

INSTRUCTIONS PERTAINING TO THE RISK OF FIRE ELECTRIC SHOCK , OR INJURY TO PERSONS

WARNING: When using electric products, basic precautions should always be followed, including the following:

1. Read all the Safety and Installation Instructions and Explanation of Graphic Symbols before using the product.
2. This product must be grounded. If it should malfunction or break down, grounding provides a path of least resistance for electric current to reduce the risk of electric shock. This product is equipped with a power supply cord having an equipment-grounding conductor and a grounding plug. The plug must be plugged into an appropriate outlet which is properly installed and grounded in accordance with all local codes and ordinances.

DANGER: Improper connection of the equipment-grounding conductor can result in a risk of electric shock. Do not modify the plug provided with the product – if it will not fit the outlet, have a proper outlet installed by a qualified electrician. Do not use an adaptor which defeats the function of the equipment-grounding conductor. If you are in doubt as to whether the product is properly grounded, check with a qualified serviceman or electrician.
3. Do not use this product near water – for example, near a bathtub, washbowl, kitchen sink, in a wet basement, or near a swimming pool, or the like.
4. This product should only be used with a stand or cart that is recommended by the manufacturer.
5. This product, either alone or in combination with an amplifier and speakers or headphones, may be capable of producing sound levels that could cause permanent hearing loss. Do not operate for a long period of time at a high volume level or a level that is uncomfortable. If you experience any hearing loss or ringing in the ears, you should consult an audiologist.
6. This product should be located so that its location or position does not interfere with its proper ventilation.
7. The product should be located away from heat sources such as radiators, heat registers, or other products that produce heat.
8. The product should be connected to a power supply only of the type described in the operating instructions or as marked on the product.
9. This product may be equipped with a polarized line plug (one blade wider than the other). This is a safety feature. If you are unable to insert the plug into the outlet, contact an electrician to replace your obsolete outlet. Do not defeat the safety purpose of the plug.
10. The power supply cord of the product should be unplugged from the outlet when left unused for a long period of time. When unplugging the power supply cord, do not pull on the cord, but grasp it by the plug.
11. Care should be taken so that objects do not fall and liquids are not spilled into the enclosure through openings.
12. The product should be serviced by qualified service personnel when:
 - A. The power supply cord or the plug has been damaged;
 - B. Objects have fallen, or liquid has been spilled into the product;
 - C. The product has been exposed to rain;
 - D. The product does not appear to be operating normally or exhibits a marked change in performance;
 - E. The product has been dropped, or the enclosure damaged.
13. Do not attempt to service the product beyond that described in the user maintenance instructions. All other servicing should be referred to qualified service personnel.
14. **WARNING:** Do not place objects on the product's power supply cord, or place the product in a position where anyone could trip over, walk on, or roll anything over cords of any type. Do not allow the product to rest on or be installed over cords of any type. Improper installations of this type create the possibility of a fire hazard and/or personal injury.

RADIO AND TELEVISION INTERFERENCE

WARNING: Changes or modifications to the instrument not expressly approved by Young Chang could void your authority to operate the instrument.

IMPORTANT: When connecting this product to accessories and/or other equipment use only high quality shielded cables.

NOTE: This instrument has been tested and found to comply with the limits for a Class B digital device, pursuant to Part 15 of the FCC Rules. These limits are designed to provide reasonable protection against harmful interference in a residential installation. This instrument generates, uses, and can radiate radio frequency energy and, if not installed and used in accordance with the instructions, may cause harmful interference to radio communications. However, there is no guarantee that interference will not occur in a particular installation. If this instrument does cause harmful interference to radio or television reception, which can be determined by turning the instrument off and on, the user is encouraged to try to correct the interference by one or more of the following measures:

- Reorient or relocate the receiving antenna.

- Increase the separation between the instrument and the receiver.
- Connect the instrument into an outlet on a circuit other than the one to which the receiver is connected.
- If necessary consult your dealer or an experienced radio/television technician for additional suggestions.

The normal function of the product may be disturbed by strong electromagnetic interference. If so, simply reset the product to resume normal operation by following the instructions in the manual. If normal function does not resume, please use the product in another location.

NOTICE

This apparatus does not exceed the Class B limits for radio noise emissions from digital apparatus set out in the Radio Interference Regulations of the Canadian Department of Communications.

AVIS

Le présent appareil numérique n'émet pas de bruits radioélectriques dépassant les limites applicables aux appareils numériques de la class B prescrites dans le Règlement sur le brouillage radioélectrique édicté par le ministère des Communications du Canada.

SAVE THESE INSTRUCTIONS

IMPORTANT SAFETY INSTRUCTIONS

- 1) Read these instructions.
- 2) Keep these instructions.
- 3) Heed all warnings.
- 4) Follow all instructions.
- 5) Do not use this apparatus near water.
- 6) Clean only with dry cloth.
- 7) Do not block any of the ventilation openings. Install in accordance with the manufacturer's instructions.
- 8) Do not install near any heat sources such as radiators, heat registers, stoves, or other apparatus (including amplifiers) that produce heat.
- 9) Do not defeat the safety purpose of the polarized or grounding-type plug. A polarized plug has two blades with one wider than the other. A grounding type plug has two blades and a third grounding prong. The wide blade or the third prong are provided for your safety. If the provided plug does not fit into your outlet, consult an electrician for replacement of the obsolete outlet
- 10) Protect the power cord from being walked on or pinched, particularly at plugs, convenience receptacles, and the point where they exit from the apparatus.
- 11) Only use attachments/accessories specified by the manufacturer.
- 12) Use only with a cart, stand, tripod, bracket, or table specified by the manufacturer, or sold with the apparatus. When a cart is used, use caution when moving the cart/apparatus combination to avoid injury from tip-over.
- 13) Unplug this apparatus during lightning storms or when unused for long periods of time.
- 14) Refer all servicing to qualified service personnel. Servicing is required when the apparatus has been damaged in any way, such as power-supply cord or plug is damaged, liquid has been spilled or objects have fallen into the apparatus, the apparatus has been exposed to rain or moisture, does not operate normally, or has been dropped.



Warning: To reduce the risk of fire or electric shock, do not expose this apparatus to rain or moisture. Do not expose this equipment to dripping or splashing and ensure that no objects filled with liquids, such as vases, are placed on the equipment.

To completely disconnect this equipment from the AC Mains, disconnect the power supply cord plug from the AC receptacle.

This product contains chemicals known to the State of California to cause cancer or birth defects or other reproductive harm. Wash hands after handling.

Remarks: As with most electronic equipment, the outer cables may contain phthalate and the copper alloy power plug contains lead.

Kurzweil International Contacts

Contact the Kurzweil office listed below to locate your local Kurzweil representative.

US Customers:

American Music & Sound
925 Broadbeck Dr #220
Newbury Park, CA 91320

Tel: 800-431-2609

Fax: 818-597-0411

Email: info@americanmusicandsound.com

Customers outside the US:

Young Chang Co., LTD.
178-55, Gajwa-Dong, Seo-Ku
Incheon, Korea Post Code: 404-714

Tel: +82-32-570-1576

Fax: +82-32-576-2340



www.kurzweil.com



support@kurzweil.com



www.facebook.com/kurzweilmusicsystems/



www.twitter.com/KurzweilMusic



www.youtube.com/user/KurzweilTutorials

Contents

Introducing Artis	1-1
Reading this guide with the Artis7	1-1
Main Features	1-1
Sounds	1-2
Keyboard and Controllers	1-2
Pedals (Optional)	1-2
Keeping the Artis up to date.....	1-3
Do You Have Everything?	1-3
Music Rack (Optional).....	1-3
Getting Started	2-1
Before You Start.....	2-1
Quick Start	2-1
Using Artis	2-2
Start Up Details:	
The Rear Panel.....	2-3
The AC Power Jack.....	2-3
The USB Ports	2-3
The MIDI (IN and OUT) Ports	2-4
The Pedal Jacks.....	2-4
The SW1 (Sustain) and SW2 Jacks	2-4
The CC Jack	2-4
The Audio (LEFT/MONO and RIGHT) Jacks	2-5
The Headphones Jack	2-5
Connecting the Power Cable (Line Cord).....	2-5
Connecting to Your Audio System.....	2-5
Connecting Pedals	2-7
Connecting a Single Switch Pedal	2-7
Connecting a Dual Switch Pedal.....	2-8
Connecting a Half Damper Pedal.....	2-9
Connecting a Continuous Control Pedal	2-9
Connecting MIDI	2-11
Basic MIDI Hookup	2-11
Connecting More Sound Modules.....	2-11

Connecting to a Computer Sequencer.....	2-12
Selecting Programs and Multis	2-13
Features of the Artis	3-1
Powering Up Defaults	3-1
Parameters Reset To Defaults At Power-On.....	3-1
Parameters Remembered After Power-On	3-1
The Front Panel	3-2
Pitch and Modulation Wheels	3-3
Pitch Wheel.....	3-3
Modulation Wheel	3-3
Real Time Control	3-4
Sliders	3-4
Zone Mute/Volume Buttons.....	3-4
Switches.....	3-5
Foot Switches and Controllers	3-5
KB3 Buttons	3-5
Transpose & Variation Buttons	3-6
Transpose	3-6
Variation	3-6
Master EQ	3-7
Save Button	3-8
Audio In	3-9
Mode Buttons	3-10
Program Button	3-10
Multi Button	3-10
Global Button	3-10
Navigation	3-11
The LCD Display	3-11
Previous (-) and Next (+) Value Buttons.....	3-11
Param / Channel Buttons	3-11
Alpha Wheel.....	3-12
Display Contrast Knob	3-12
Sound Select	3-13
CATEGORY	3-13
PROGRAM / MULTI	3-13
KB3 LED	3-14
Double Button Presses	3-14
Value Jump	3-14

Parameter Jump.....	3-15
Reset Transposition	3-15
MIDI Program Change	3-16
Program Demo.....	3-16
Demo.....	3-17
Panic	3-17
Assign	3-18
Enter + Zone (1–4) Button	3-18
Enter + Controller	3-18
Enter + Key.....	3-18
Terminology.....	4-1
The Operating Modes	5-1
Program Mode	5-1
Multi Mode.....	5-2
Global Mode.....	5-2
Functions	5-3
The Split Function	5-3
The Layer Function	5-3
MIDI Program Change Function	5-4
PROG (Program).....	5-5
PCH (MIDI Program) & BANK (MIDI Bank)	5-5
Demo Function.....	5-6
Program Demo Function.....	5-6
Multi Edit Mode.....	5-7
Program Mode	6-1
About Program Mode.....	6-1
Selecting Programs.....	6-2
Program Demo.....	6-2
The Display	6-3
Pop Up Messages	6-4
Alpha Wheel & Previous (–) and Next (+) Value Buttons	6-4
Value Jump Buttons	6-4
Category & Program/Multi Buttons.....	6-5
Choosing Category Default Programs	6-6
Choosing Favorites	6-7
Transposition	6-8
Parameter Assignments	6-9
The Split Function	6-10

Prog (Split Program)	6-11
Vol (Split Volume)	6-11
Key (Split Key)	6-12
Transpose (Split Transposition)	6-12
Saving a Split	6-12
The Layer Function	6-13
Prog (Layer Program)	6-14
Vol (Layer Volume)	6-14
Transpose (Layer Transposition)	6-14
Saving a Layer	6-15
Changing the Transmit MIDI Channel.....	6-16
Panic.....	6-17
Save & Delete User Programs.....	6-18
Changing ID Numbers.....	6-18
Naming a User Program	6-19
Saving a User Program.....	6-20
Deleting User Programs.....	6-21
INFO.....	6-22
Multi Mode	7-1
About Multi Mode	7-1
Selecting Multis	7-2
The Display	7-2
Alpha Wheel & Previous (–) and Next (+) Value Buttons.....	7-3
Value Jump Buttons	7-3
Category & Program/Multi Buttons.....	7-4
Choosing Category Default Multis.....	7-4
Choosing Favorites	7-5
About Zones.....	7-6
Muting Zones	7-6
Transposition.....	7-7
The Split Function	7-8
Prog (Split Program)	7-8
Vol (Split Volume)	7-9
Key (Split Key)	7-9
Saving a Split	7-9
The Layer Function	7-10
Prog (Layer Program)	7-10
Vol (Layer Volume)	7-11
Saving a Layer	7-11

Save & Delete User Multis 7-12
 Changing ID Numbers..... 7-13
 Naming a User Multi..... 7-14
 Saving a User Multi 7-15
 Deleting User Multis 7-16

Multi Edit Mode..... 8-1

About Multi Edit Mode..... 8-1

Selecting Parameters 8-3

The Display 8-3
 Changing Zones..... 8-3
 Param / Channel Buttons 8-4
 Alpha Wheel & Previous (–) and Next (+) Value Buttons 8-4
 Value Jump Double Button Press 8-4
 Param Jump Double Button Press..... 8-4
 Assign 8-5
 Enter + Zone (1–4) Button 8-5
 Enter + Controller 8-5
 Enter + Key..... 8-5

Zone Parameters 8-6

MAIN Page..... 8-6
 Program..... 8-6
 MIDI Channel..... 8-7
 Destination..... 8-7
 Status..... 8-9
 Entry Volume 8-9
 Aux Send Level..... 8-9
 KEYS Page 8-10
 Transpose..... 8-10
 Low Key 8-10
 High Key 8-10
 Low Velocity..... 8-11
 High Velocity 8-11
 Note Map 8-11
 MIDI Page 8-12
 MIDI Bank..... 8-12
 MIDI Program..... 8-13
 Differing Program Numbers 8-13
 Entry Program Change 8-14
 Bank Mode..... 8-14
 Bend Range Down..... 8-14
 Bend Range Up 8-14
 CTRLS Page 8-15
 WHEEL page 8-15

SLIDER page.....	8-16
PEDAL page.....	8-16
SWITCHES page.....	8-17
The Switch Parameters.....	8-18
Mode.....	8-18
Dest (Destination).....	8-18
On Value.....	8-18
Off Value.....	8-18
Entry State.....	8-19
Exit State.....	8-19
Continuous Controller Parameters.....	8-19
Dest (Destination).....	8-19
Entry Value.....	8-22
Exit Value.....	8-22
COMMON Page.....	8-23
AuxFX.....	8-23
Aux FX Channel.....	8-23
KB3 Channel.....	8-24
Tempo.....	8-24
About Auxiliary Effects.....	8-25
Save and Delete User Multis.....	8-26
Global Mode.....	9-1
About Global Mode.....	9-1
Selecting and Editing Parameters.....	9-2
MASTER Page.....	9-2
Tune.....	9-3
Velocity Map.....	9-3
View.....	9-4
FX Select (FXSel).....	9-4
Auto Power Off.....	9-5
Auto Power Off Time.....	9-5
Auto Power Off Message.....	9-5
Pedal Noise.....	9-6
Pedal Switch Overrides.....	9-6
CC Pedal Override.....	9-7
Rotary S/F Override.....	9-7
MIDI Page.....	9-8
Destination.....	9-8
Bank Select (BankSelect).....	9-9
Program Change.....	9-10
Channel Enable (ChanEn).....	9-10

Local Keyboard Channel (Local Key Channel)	9-10
Program Mode	9-10
Multi Mode	9-11
Sysex ID	9-11
INFO Page	9-12
LOAD Page.....	9-13
Pressing LOAD	9-13
Selecting PC	9-15
Selecting Device	9-16
USB connection errors.....	9-16
STORE Page.....	9-17
Pressing STORE.....	9-18
RESET Page.....	9-20
Reset Global Mode parameters only (Soft Reset)	9-20
Reset Artis to its factory state (Hard Reset)	9-22
System Mode	10-1
Run Artis	10-2
System Update.....	10-3
Install using a USB flash drive	10-3
Install using a computer/tablet	10-6
Run Diagnostics	10-8
System Reset.....	10-9
System Utilities.....	10-11
Format Flash.....	10-12
Update Module.....	10-15
Restore Older.....	10-15
Troubleshooting	11-1
Maintenance.....	11-1
Common Problems.....	11-1
Power Problems.....	11-1
Powers up, Display is Blank.....	11-2
Audio Problems.....	11-2
MIDI Problems.....	11-4
Pedal Problems.....	11-5
Switch Pedal Problems	11-5
Continuous Control and Half Damper Pedal Problems.....	11-5
If None of the Above.....	11-6

Restoring Factory Defaults.....	11-6
Diagnostics.....	11-7
MIDI Implementation	A-1
Physical Specifications	B-1
Programs	C-1
KB3 Programs	D-1
Introducing KB3 Programs.....	D-1
First Some History.....	D-1
Drawbars	D-2
KB3 Mode Buttons	D-2
Brake.....	D-2
Chorus/Vibrato	D-2
On/Off	D-2
Chor/Vib.....	D-2
Chorus/Vibrato Depth	D-3
Percussion	D-3
Percussion On/Off	D-3
Percussion Loud/Soft.....	D-3
Percussion Decay F/S	D-3
Percussion Pitch H/L	D-3
KeyClick	D-3
Variation	D-4
Index.....	I-1

Chapter 1

Introducing Artis

Congratulations on your purchase of the Kurzweil Artis® Stage Piano!

This manual will help you get acquainted with your new instrument. Be sure to keep the manual on hand as you continue to familiarize yourself with the features and functions of the Artis.



Reading this guide with the Artis7

This Getting Started Guide is designed to cover both the Artis and Artis7 Stage Pianos. Both instruments share common features and the term “Artis” is used to cover a description of both instruments. Where there are differences, we use the name “Artis7” to help instruct owners of that instrument.

Main Features

The Artis Stage Piano is the beginning of the next generation of Kurzweil’s professional performance instruments. It boasts hundreds of excellent preset sounds (including a new German Grand Piano) already on-board and ready to be played with 128 voice polyphony. Artis also includes our fully featured Kurzweil KB3 organ simulator (from our PC3 Series) designed to emulate classic tone wheel organs.

The Artis is also a very capable MIDI controller ideally suited for controlling additional sound modules and as input to a sequencer.

Sounds

- New German Grand Piano
- ROM sounds from Kurzweil's acclaimed PC3 series
- Enhanced Kore64 ROM
- Full KB3 organ simulations with 9 sliders as drawbars
- 256 Factory Programs divided into 16 Categories
- 256 User slots to save your own Programs
- 256 Factory Multis
- 256 User slots to save your own Multis
- MP3 player audio input jack
- Full 128 voices of polyphony

Keyboard and Controllers

The Artis has an 88-key fully-weighted hammer action keyboard (**Artis7 has 76-key semi-weighted keys**) that provides you with a piano-like feel without adding excessive weight to the instrument. The array of physical controllers includes:

- 9 assignable sliders
- 6 programmable switches
- A pitch wheel
- A modulation wheel
- 2 jacks on the rear panel for up to 4 optional switch pedals or 2 half damper pedals: SW1 (Sustain) & SW2
- 1 jack on the rear panel for an optional continuous controller pedal: CC (Volume)

Pedals (Optional)

As described above, the Artis has three jacks on the rear panel for optional pedal controllers. Two jacks for switch pedals, which are typically used to control two-state (i.e., on / off) parameters such as sustain, sostenuto, and mute Zone. The third jack is for a continuous control (or CC) pedal typically used to control multi-state (i.e., "continuous") parameters such as volume or wah.

Your Kurzweil dealer stocks the following pedals:

- KP-1 Single piano-style switch pedal
- KP-1H Single piano-style Half Damper pedal
- CC-1 Continuous pedal

Keeping the Artis up to date

Be sure to check the Kurzweil Music Systems website at <http://www.kurzweil.com> for new documentation and the latest software updates for Artis.

Do You Have Everything?

Your Artis package should contain the following in addition to your instrument:

- Power cable
- Switch pedal
- USB cable (Type-A-to-Type-B)
- 4 self adhesive feet (see page 2-1)
- Artis Musician's Guide (this book)

If you don't have any of these components, please contact your Kurzweil / Young Chang dealer to get them.

Music Rack (Optional)

The optional KMR2 Music Rack attachment is a holder for sheet music or a computer tablet device for the Artis. (**Music Rack option can not be used with the Artis7.**)

Contact your Kurzweil dealer for the KMR2 Music Rack.

Please refer to the instructions that come with the KMR2 on attaching the music rack to the Artis.

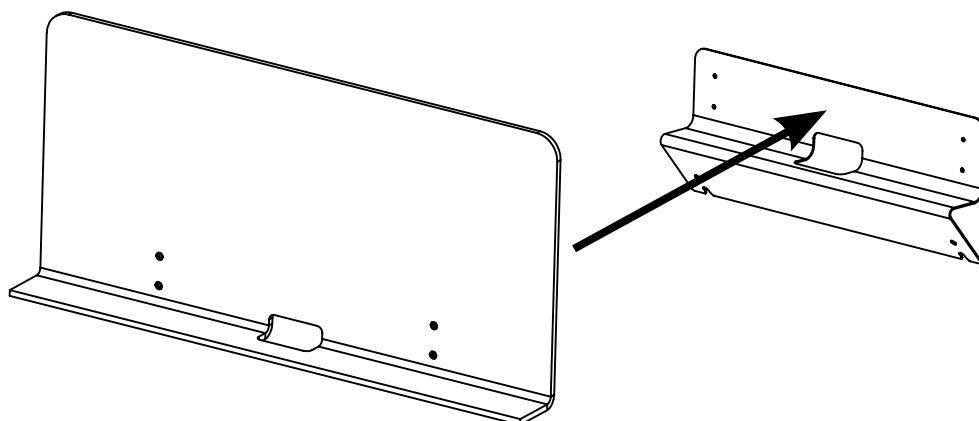

Introducing Artis

Keeping the Artis up to date

Chapter 2

Getting Started

Getting a new keyboard is always exciting and the first thing most users want to do is unpack the keyboard and check things out. This chapter will help you hook up the Artis to your sound system and MIDI system, give you a quick overview, and show you how to get some sound out of the Artis.

Before You Start...

Don't connect anything until you make sure the Artis is properly and safely situated. If your Artis keyboard has been out in the cold, give it time to warm up to room temperature before starting it, since condensation may have formed inside.

Quick Start

1. Set the keyboard on a hard, flat, level surface.
2. Four adhesive-backed rubber feet are provided with Artis. Carefully turn the keyboard over onto a soft surface, remove the paper backing from the rubber feet and attach them.

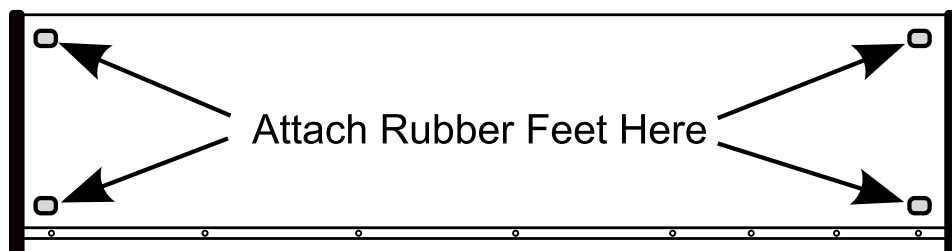

NOTE : Unless the instrument will always be used with a keyboard stand, attachment of the rubber feet is strongly advised. Otherwise protruding screws will scratch the tabletop and may increase the key action sound.

Getting Started

Quick Start

3. Connect the AC power cord to the Artis. Before plugging the cable into the power outlet, check that the power is compatible with the Artis. The Artis runs on AC power and works with voltages from 90 - 260 volts at 50–60 Hz (**Artis7 is 100-240 volts at 50–60 Hz**). The voltage level is detected and set automatically by the Artis. If your power source does not have the standard three hole outlet, you should take the time to install a proper grounding system. If your power outlet is not within these ranges it is recommended you use an appropriate adaptor.
4. Plug the power cable into the wall.
5. Plug the Switch Pedal into the marked SW1 (Sustain) Pedal jack on the Artis rear panel.
6. Connect stereo headphones to the headphone jack on the front left panel (**Artis7 rear panel**), or connect the audio outputs to your mixer or amplifier inputs using standard (1/4-inch) audio cables (use the Left out for mono). Balanced (“TRS” or “Stereo”) cables are recommended if your mixer or amp supports balanced inputs.
7. Make sure your sound system is at a safe volume level. Also make sure that the Artis MASTER VOLUME slider (on the far left side of the front panel) is all the way down.

Using Artis

1. Power up the Artis, and then raise the MASTER VOLUME slider, and mixer/amp volume. Your Artis keyboard starts up in Program Mode by default. Press one of the buttons under the “Mode” label to the right of the display to switch Modes.

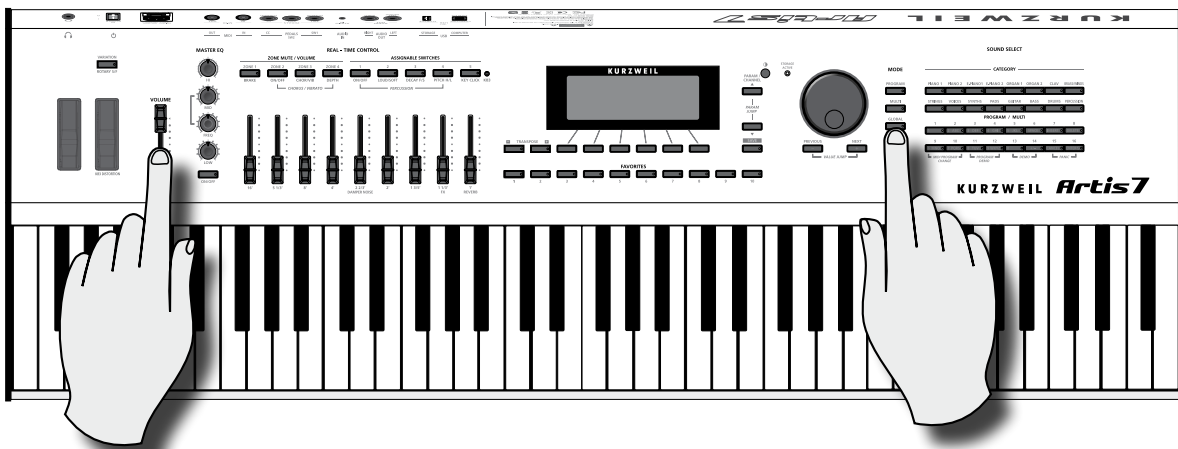

Master Volume Slider

Mode Selection

2. If you are connected to a mixing board and hear distortion, reduce the gain level on your mixing board, or use the pad (*a switch that decreases the input audio signal level, typically by 20dB*) if it has one.
3. Scroll through the Programs using the Alpha Wheel, the Previous and Next buttons, or press a Category button to audition the sounds in Artis. Take note that initially there are no Programs or Multis stored in the Favorites buttons.

Start Up Details: The Rear Panel

The Artis & Artis7 rear panel connections.

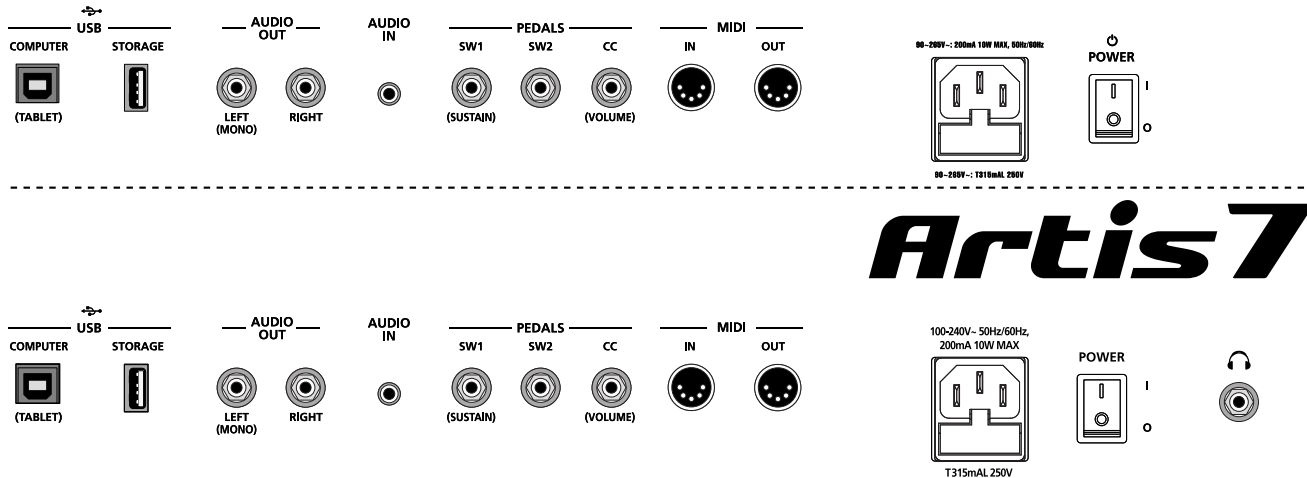

The AC Power Jack

Use the AC power jack to connect the Artis to the AC power supply.

The USB Ports

Use the USB ports to connect the Artis to a computer/tablet in order to do the following:

- Use the Artis as a MIDI controller to play software instruments on a computer.
- Use a computer program to sequence multitrack songs on the Artis.
- Use a computer/tablet to manage the user data contents of the Artis.
- Update the software and sounds of the Artis.
- Store custom Programs and Multis on a USB flash drive.

Be sure to check the Kurzweil Music Systems website at www.kurzweil.com for new documentation and software updates before using your new instrument.

Getting Started

Start Up Details: The Rear Panel

The MIDI (IN and OUT) Ports

Use the MIDI ports to communicate with other MIDI modules and controllers. The OUT port is the MIDI transmitting port, and the IN port is the MIDI receiving port.

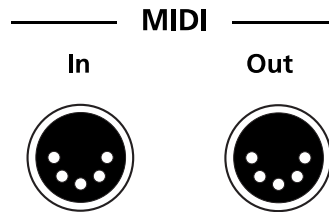

The Pedal Jacks

Use the three pedal jacks to connect controller pedals to Artis.

The SW1 (Sustain) and SW2 Jacks

Use the pedal jacks to connect switch pedals. A switch pedal is a physical controller typically used to control two-state (i.e., “on / off”) parameters, such as sustain, sostenuto, and Mute Zone.

It is possible to connect up to 2 dual switch pedals having a single stereo plug into the SW1 and SW2 jacks, (see Connecting a Dual Switch Pedal on page 2-8) or up to 2 half damper pedals each having a single stereo plug.



NOTE : It is not recommended to plug CC pedals into the SW inputs. Due to the flexible switch pedal support, CC pedals may not operate as expected in these inputs.

The CC Jack

Use the CC pedal jack to connect a continuous control (or CC) pedal. A CC pedal is a physical controller typically used to control multi-state (i.e., “continuous”) parameters such as volume or wah.



NOTE : Only CC pedals should be connected to the CC pedal input.

For more information on connecting pedals, see page 2-7.

The Audio (LEFT/MONO and RIGHT) Jacks

Use the LEFT/MONO and RIGHT audio jacks to connect the Artis to your audio system. The Artis can use either balanced (TRS) or unbalanced (TS) cables. However it is recommended to use balanced (TRS) cables where possible, and where your mixer or amp supports balanced inputs.

The Headphones Jack

Use the HEADPHONES jack to listen to the Artis on stereo headphones.

The headphone jack is located on the left rear panel of the instrument on the Artis7, and on the left front panel of the Artis.

You will need a 1/8-inch-to-1/4-inch adapter in order to use headphones that have a smaller mini plug connector.

Connecting the Power Cable (Line Cord)

The Artis runs on AC power and works with voltages from 90 - 265 volts at 50–60 Hz. The voltage level is detected and set automatically by the Artis. As you face the back of the Artis, the power connection is on the right. First connect the power cable to the Artis, then plug the power cable into a grounded outlet. If your power source does not have the standard three hole outlet, you should take the time to install a proper grounding system. This will reduce the risk of a shock.

Connecting to Your Audio System

After you've turned down the level on your sound system, connect the Artis analog audio outputs to your sound system using a pair of balanced (TRS or "stereo") or unbalanced (TS or "mono") audio cables. Unbalanced cables will always work, but if you're going into balanced inputs, use balanced cables for a better signal-to-noise ratio and a bit more volume. The Artis analog outputs are balanced.

You'll find two 1/4-inch balanced audio output jacks on the rear panel. Connect one end of each audio cable to your mixing board or PA system inputs, and connect the other end to the jacks marked Left (Mono) and Right on the rear panel of the Artis. If you have only one input available, use the Artis' Left (Mono) output to get the full signal in mono. Use the jack marked Headphones to listen to Artis on headphones. When headphones are plugged in, sound still comes through the Left and Right audio jacks.

Getting Started

Connecting Pedals

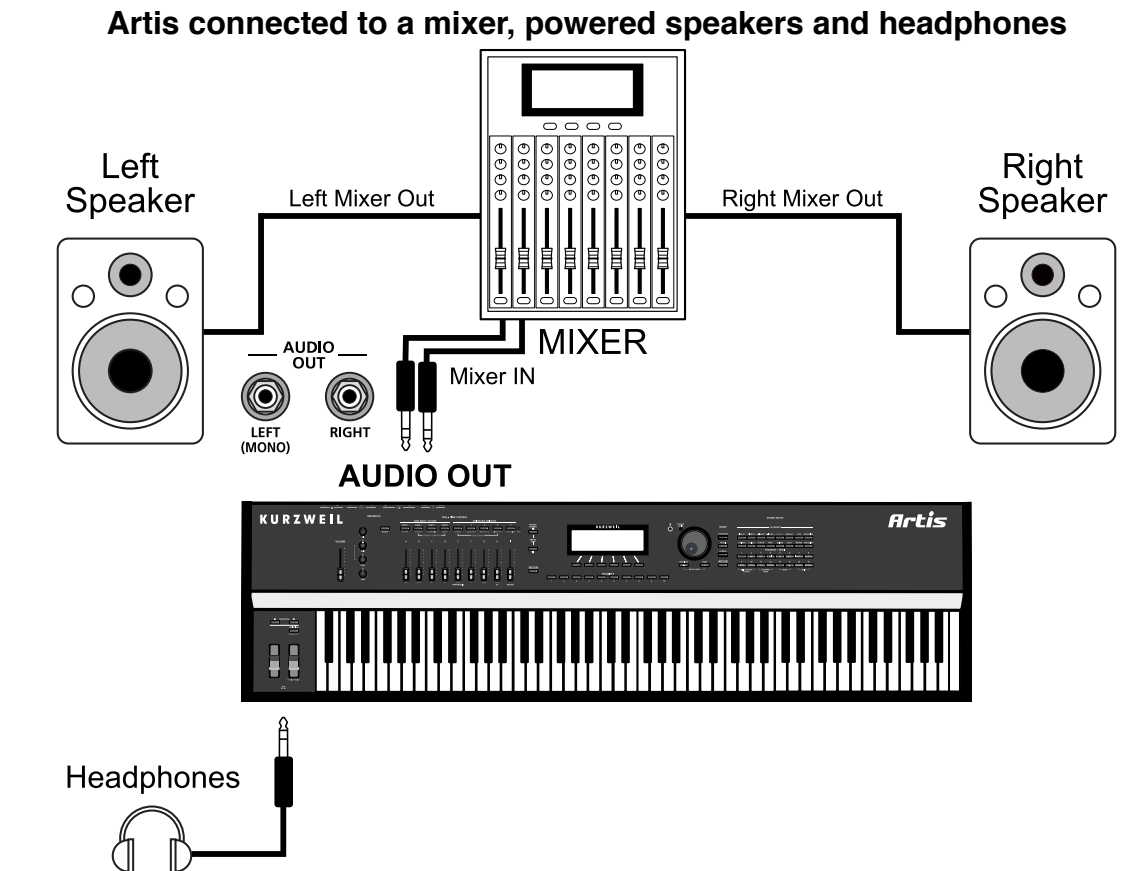
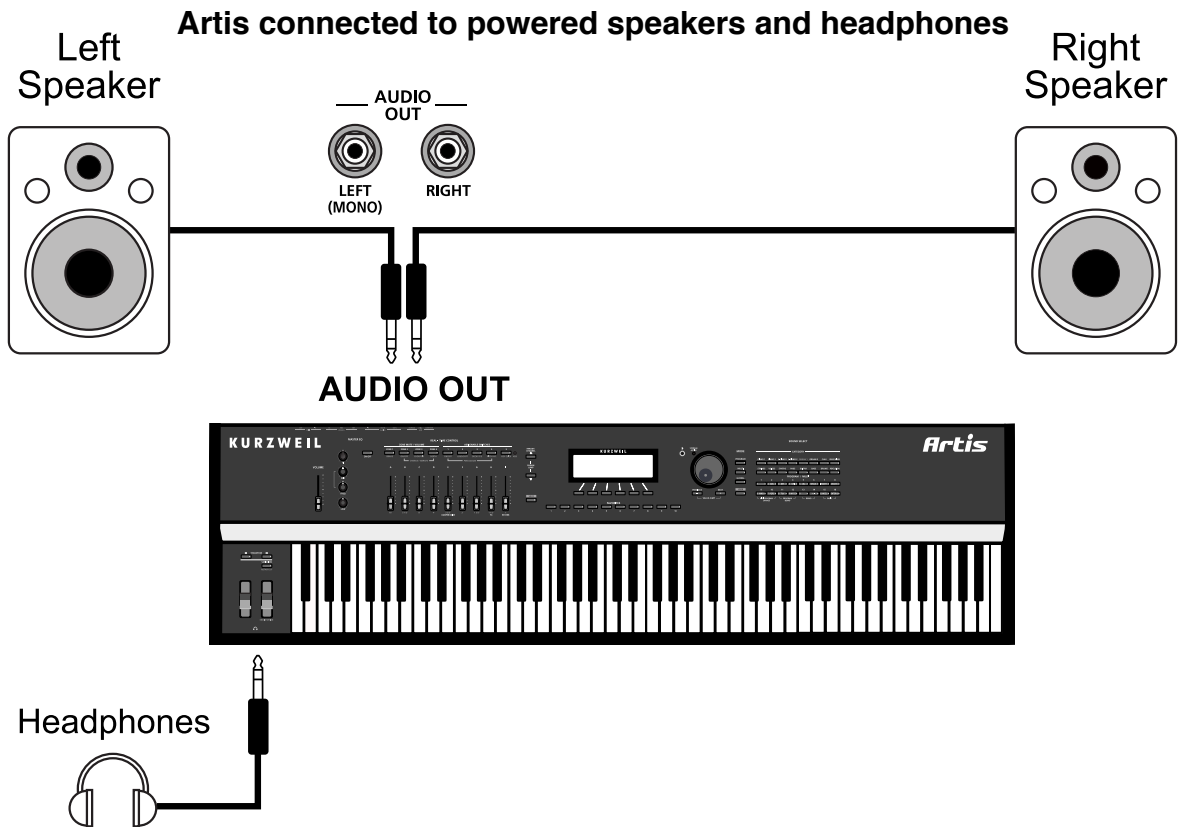

Connecting Pedals

Plug your switch, dual switch, half-damper or continuous control pedals into the corresponding jacks on Artis rear panel. We recommend using the Kurzweil pedals described in Pedals (Optional) on page 1-2. However you can use almost any switch or continuous control pedal that adheres to the following specifications.

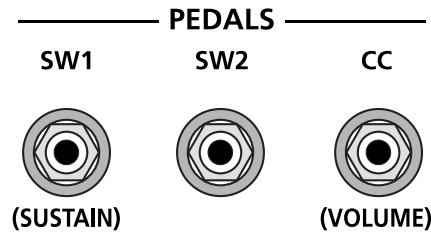

Switch Pedals	1/4 inch tip-sleeve (mono) plug or, 1/4 inch tip-ring-sleeve plug configured as dual switches (TS and RS) or 2 terminal continuous pedal (half-damper).
Continuous Control (CC) Pedals	10 kΩ linear-taper potentiometer, 1/4 inch tip-ring-sleeve (stereo) plug with the wiper connected to the tip.

Pedals are all independently assignable within each Zone of every Multi.

Here are the default control settings for the three pedals used by Artis:

SW 1 Pedal	Sustain (MIDI 64)
SW 2 Pedal	Sostenuto (MIDI 66)
CC Pedal	Expression (MIDI 11)



NOTE : Ensure that pedals are plugged in before powering up the Artis and do not step on the switch pedals when powering up, as the pedal type and state of the pedal is detected as part of the power up sequence.

Connecting a Single Switch Pedal

When a single switch pedal is plugged into the SW1 Pedal jack on the rear panel, a single switch pedal will, by default, act like a sustain pedal. When a single switch pedal is plugged into the SW2 Pedal jack, the single switch pedal will, by default, act like a sostenuto pedal.

Getting Started

Connecting Pedals

Of course this can be changed by programming, as described in Multi Mode on page 7-1. The default assignments of the pedals can also be overridden in Global Mode as described on page 9-6.

If you are not using a Kurzweil switch pedal, make sure it's connected before you turn on the Artis. This ensures that the pedal will work properly (it might function in reverse—off when it's down and on when it's up—if you turn on your Artis before plugging in the pedal). Similarly, don't press any of your switch pedals while powering up, as the Artis verifies each pedal's orientation during power-up. If you're pressing a pedal, you might cause it to work in reverse.

See Switch Pedal Problems on page 11-5 if you are having trouble with your switch pedal.

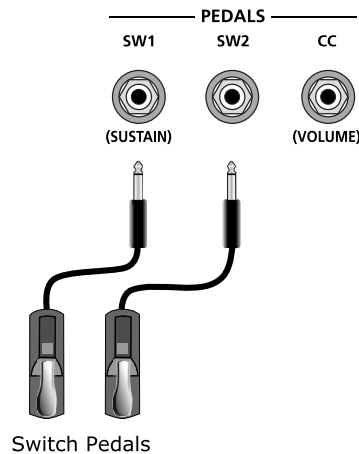

Connecting a Dual Switch Pedal

You can connect a dual switch pedal with a single stereo plug into the SW1 Pedal and SW2 Pedal jacks. Both SW1 and SW2 can support a dual pedal each allowing up to 4 pedals to be utilized by the Artis. These are enumerated as SW1a, SW1b, SW2a and SW2b. The Artis will recognize dual pedals that are wired as TS and RS.

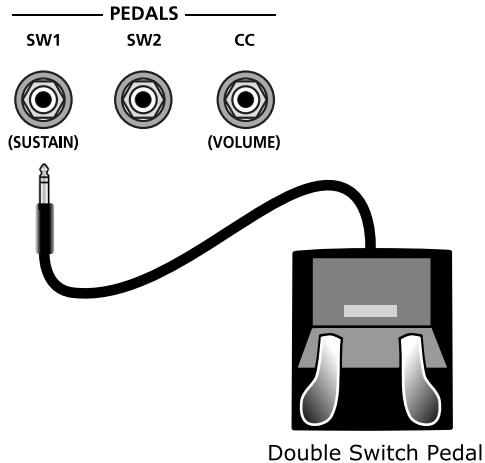

If you're not familiar with traditional piano technique, the sostenuto (center) pedal on a grand piano allows one to hold chords in the bass while continuing to play the melody without the latter notes sustaining. Any keys that are down when you depress the pedal will sustain when you let go of the keys, but new notes played afterward will not be sustained. Releasing the pedal puts things back to normal. Of course it can be programmed to do other functions as well.

Connecting a Half Damper Pedal

Half Damper pedals where the wiper is connected to the tip (such as the Kurzweil KP-1H) can be connected to the SW1 and SW2 inputs on the rear panel. Some pedals have the wiper connected to the ring, and these pedals will require an adaptor to work with the Artis. Half damper pedals can be used to control external software and sound modules via MIDI, enabling finer control of sustain than a standard switch pedal.

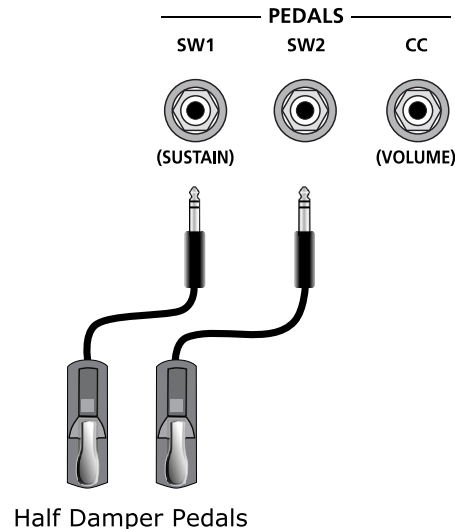

Connecting a Continuous Control Pedal

A continuous control pedal can be very useful for controlling volume, wah, or other effects by foot.

The Kurzweil CC-1 continuous control pedal will work best with the Artis, but it is also possible to use third-party continuous control pedals designed for synthesizers.



NOTE : Using a third-party continuous control pedal / volume pedal may or may not be satisfactory depending on how it is constructed.

See Continuous Control and Half-Damper Pedal Problems on page 11-5 if you are having trouble with your continuous control pedal.

Getting Started

Connecting Pedals

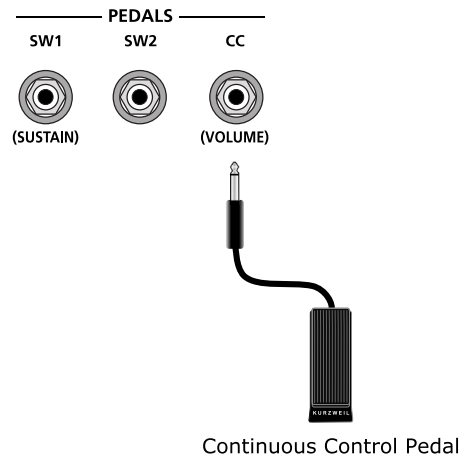

The defaults assignment for the Switch Pedals is summarized in the table below.

Pedal	Single Switch Default	Dual Switch Default
SW1a	Sustain (MIDI CC#64)	Sustain (MIDI CC#64)
SW1b		Sostenuto (MIDI CC#66)
SW2a	Sostenuto (MIDI CC#66)	Sostenuto (MIDI CC#66)
SW2b		Soft (MIDI CC#67)
CC	Expression (MIDI CC# 11)	Expression (MIDI CC#11)

Connecting MIDI

In addition to being a performance-suited musical instrument, the Artis is a powerful, but easy to use MIDI controller. For descriptions of how to customize the Artis as a MIDI controller, and how to use its MIDI controller capabilities to their fullest potential, see Multi Mode on page 7-1.

Basic MIDI Hookup

To use the Artis as a MIDI controller for another sound module, use a MIDI cable to connect the MIDI port marked “Out” to the MIDI input port of the module that you want to control.

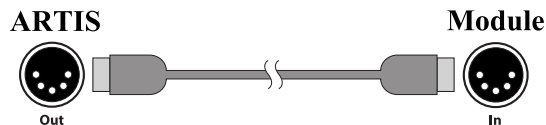

To control the Artis using another MIDI controller, use a MIDI cable to connect the MIDI port marked “In” to the MIDI output port of the controller that you will be using.

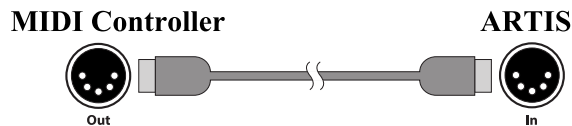

Connecting More Sound Modules

In order to connect multiple sound modules to be controlled by a single MIDI controller, the Artis must either be :

- (1) Used as the controller.
- (2) Or the last module in the MIDI daisy chain.

The reason is because the Artis does not include a Thru MIDI port; however, this simply means that the Artis must be at the start or at the end of the MIDI daisy chain.

Using the Artis as the controller, connect the MIDI Out port of the MIDI In port of the first module, and then connect that module's MIDI Thru port to the input of the next module, and so on, until the last module is connected.

The MIDI chain should end in the MIDI In port of the last module.

Getting Started

Connecting MIDI

Scenario 1: Artis as the MIDI controller

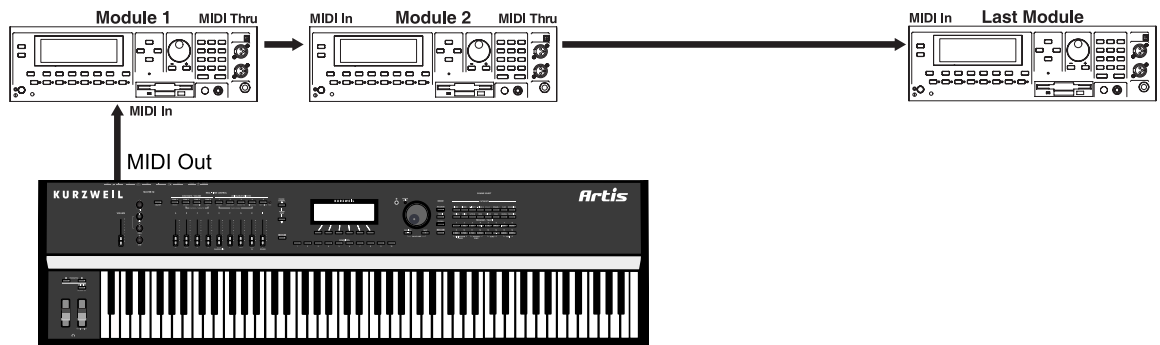

Scenario 2: Artis as the last module in the MIDI chain

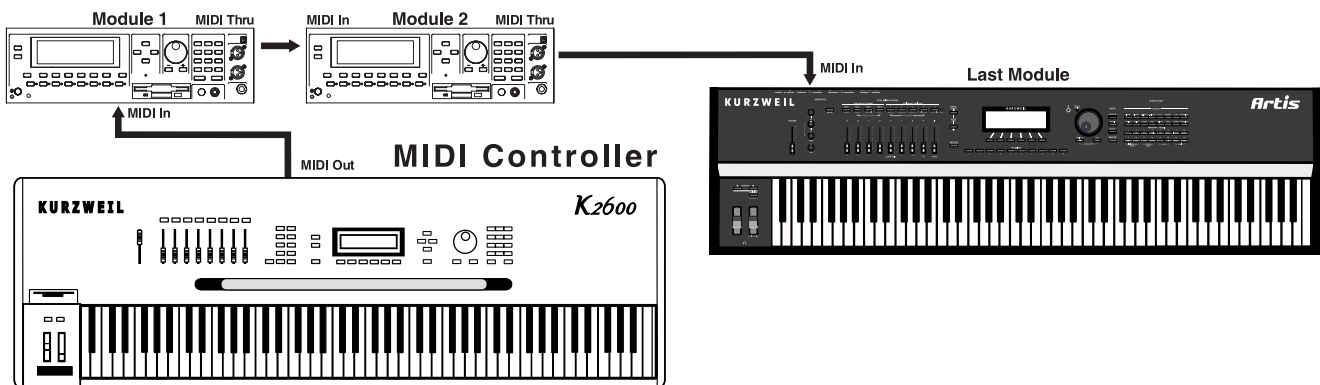

Connecting to a Computer Sequencer

To connect the Artis to a computer/tablet, simply connect Artis using the provided or compatible cable.

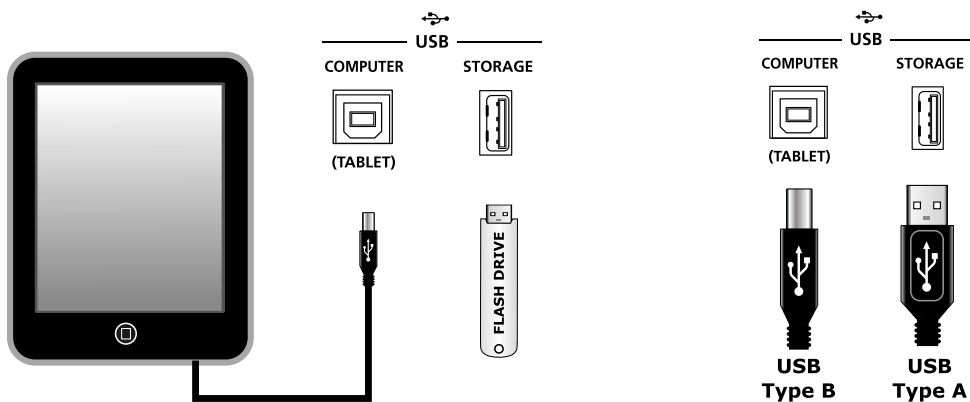

If you wish to use your own cable, make sure that it is a Type-A-to-Type-B USB cable (the USB port of Artis being Type B). By default, the Artis will act as a MIDI controller (rather than a hard drive) when connected to a computer.

Selecting Programs and Multis

The Artis supports two types of sounds. The first type is a Program, and these are normally a single instrument, such as a piano, or an organ. A Program is similar to a “preset” or “patch” on other synthesizers. The Artis has 256 factory Programs, and the space for a further 256 user Programs. Both factory and user Programs are arranged into 16 categories of 16 sounds each.

The other type of sound is the more complex Multi. A Multi is a combination of Programs arranged as layers and splits across the keyboard. They are similar to setups, from the Kurzweil PC series, SP series and K2 series, and are similar to Combis or Multis from other synthesizers. The Artis has 256 factory Multis and space for a further 256 user Multis. Similar to Programs, both factory and user Multis are arranged into 16 categories of 16 sounds each.

The Artis has been designed so that it is quick and easy to select Programs and Multis from the front panel.

Use the following guide to audition the factory sounds on the Artis. Program and Multi selection are covered in more detail later in the manual.

The Artis always starts in Program Mode. If you wish to play a Multi, simply press the Multi Button. The Multi Button will light up to show that Multi Mode is selected. To return to Program Mode, from a different mode, simply press the Program button. If the User button is illuminated, then you are in the User Bank. Press the User Button to return to the Factory Bank, and the light will go out. In the Factory Bank, press one of the Category Buttons to change Category, and that Category Button will light up. Once you are in your desired Category, press one of the Program/Multi buttons to select the program you want.

To select another Program or Multi within the same Category, just press a Program/Multi Button, or use the Alpha Wheel, or Next/Previous Buttons.

To select a Program or Multi in another Category but not in the other Bank (Factory/User), press the desired Category Button, followed by the desired Program/Multi Button. The Alpha Wheel and Next/Previous Buttons will select the next Category once you get to the end of the current Category. Pressing the Category Button, will select the Default Program for that Category. The Default Category Program can be set by the user for each Category. By default the Artis has the Default Program for each Category set to the first Program of each Category. To change the Default Category Program, see page 6-6.

The Sliders, Wheels, Pedals and Buttons can control each of the factory Programs and Multis, to produce variations to the sound. Don't forget to try these out as you explore the factory sounds on the Artis.

Chapter 3

Features of the Artis

This chapter will help familiarize you with the features of the Artis. Many of these features have both general functions and mode-specific functions. For more in-depth descriptions of these features, refer to the chapters on the individual modes.

Powering Up Defaults

In general, the Artis will always remember the last selection made by the user. However, powering up the Artis resets some of these settings back to their power-on defaults.

Parameters Reset To Defaults At Power-On

- Transpose set to 0 semitones.
- MIDI Channel set to 1.
- Entering Program Mode the selected Program is set to the Category Default Program of the factory Piano1 category.
- Entering Multi Mode the selected Multi is set to the Category Default Multi of the Piano1 category.

Parameters Remembered After Power-On

- User Programs.
- User Multis.
- Favorites.
- Default Program per Category.
- Default Multi per Category.
- Master EQ settings.
- Global Mode parameters Velocity Map, View , Destination & Pedal overrides.

Features of the Artis

The Front Panel

The Front Panel

All the controls for Artis, both musical and navigational, are on its front panel.

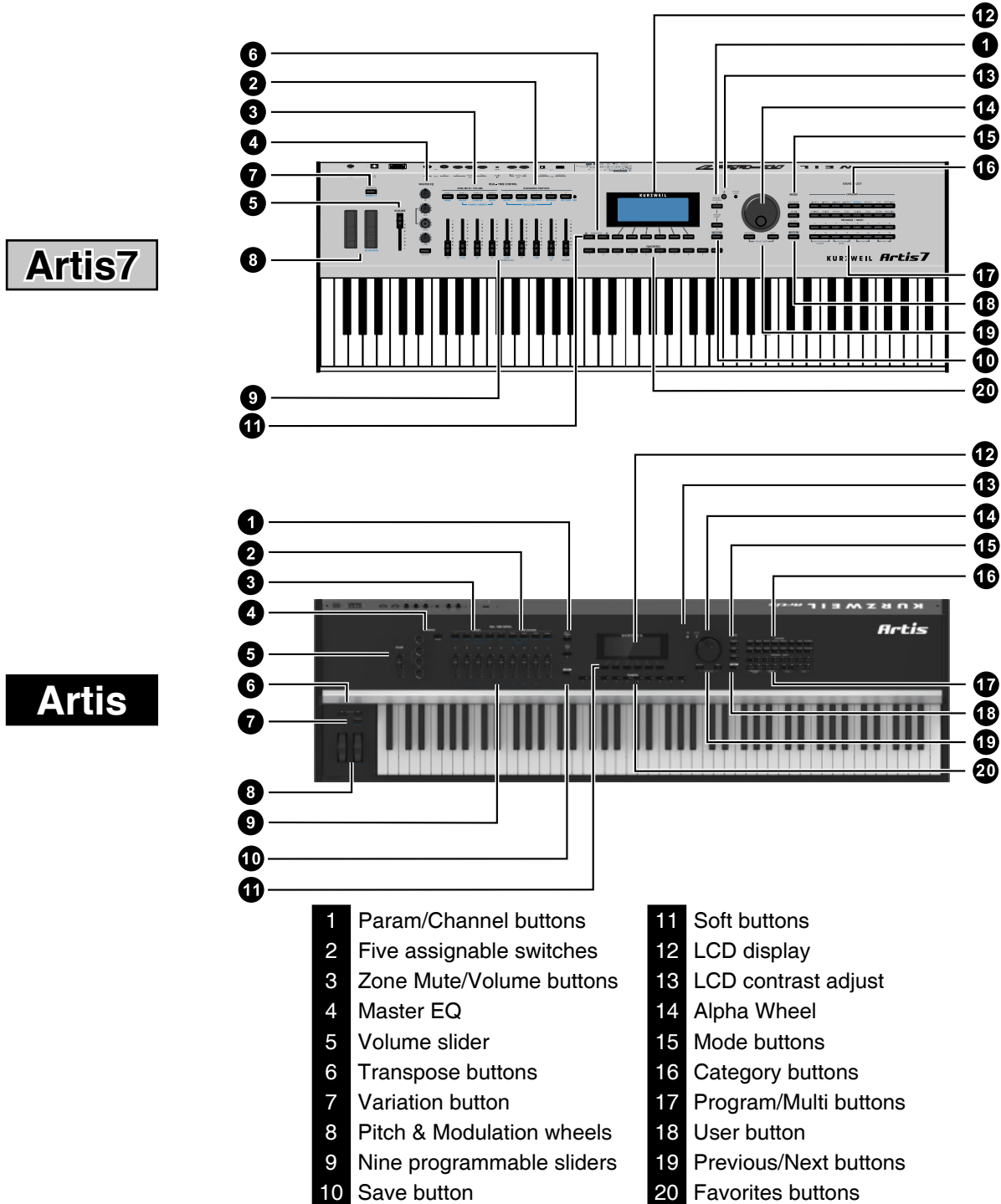

Pitch and Modulation Wheels

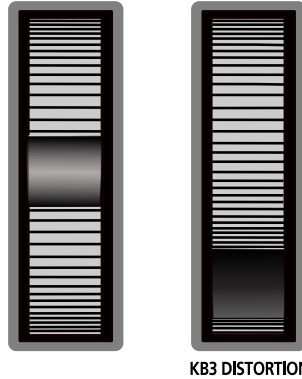

Pitch Wheel

The Pitch Wheel is the left most of the two wheels. It is spring-loaded, such that its center position is restored when it is not being used. That is because the Pitch Wheel is used for pitch-bending notes—its “off” position is in the center. Pushing the Pitch Wheel up bends the pitches of all notes up. Pulling the Pitch Wheel down bends the pitches of all notes down.

For some Programs the Pitch Wheel will not bend notes that are held by the sustain pedal. This is how many Guitar and Bass Programs are configured, allowing played notes to be bent over sustained notes. For User Multis, you can program the bend amount for the Pitch Wheel using the Bend Range Down and Bend Range Up parameters on page 8-14

Modulation Wheel

The Modulation Wheel is the right most of the two wheels. Unlike the Pitch Wheel, the Modulation Wheel is not spring loaded, and can be set to and left in any position between fully up and fully down. Typically, the Modulation Wheel is assigned to a parameter that alters some aspect of the sound (e.g., vibrato, filter depth) when changed.

When a KB3 Program is in use, the Modulation Wheel is assigned to control distortion.

Real Time Control

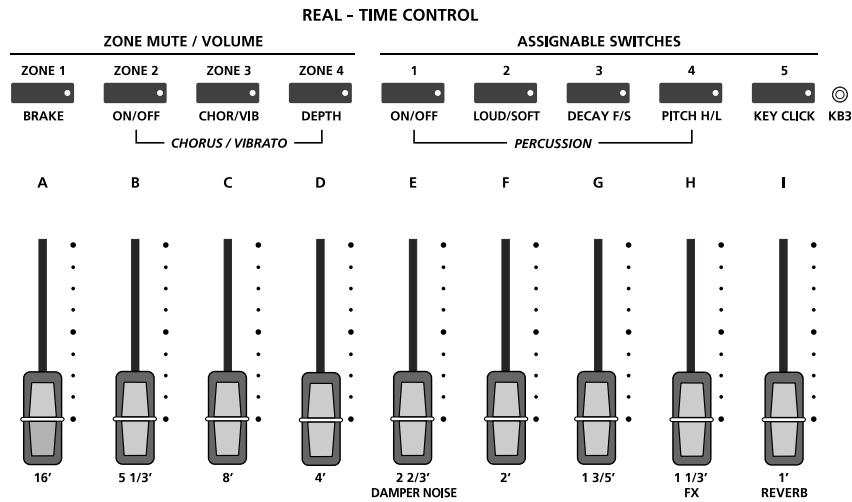

Sliders

The nine sliders on the left of the front panel are assigned to control different sound parameters and effects for each Program. In Multi Mode, Sliders A-D default to controlling volume for Zones 1-4. The sliders can also send MIDI continuous controller values to external MIDI equipment.

In Program Mode, most programs have Slider A assigned to a filter or EQ parameter in order to control brightness. In all Programs and most Multis, Slider I controls reverb amount, while Slider H usually controls a second effect, such as delay/echo amount. The remaining Sliders have different assignments depending on the selected Program/Multi. In Program Mode you can press the INFO soft button to see a list of controllers and their assignments.

If you select a KB3 Program, the nine sliders act like tonewheel organ drawbars. The labeling below the sliders applies to the KB3 Programs indicating the drawbar registers that are modified by the slider.

For KB3 Programs, the sliders operate in a similar way to a classic tone wheel organ, i.e. pulling the slider towards you increases the drawbar amount. For standard Programs the sliders have the minimum value when they are towards the player and maximum value when they are pushed away from the player.

Zone Mute/Volume Buttons

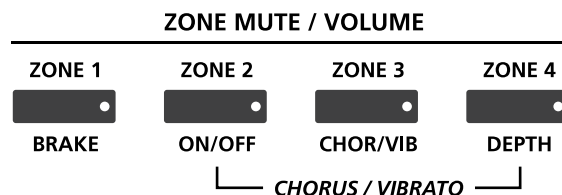

Zones are the independent regions of the keyboard that make up a Multi, for additional information see About Zones on page 7-6.

Pressing a Zone button will mute or unmute the Zone. An active/unmuted Zone button has a lit green LED. The LED of an inactive/muted Zone button is not lit.

Switches

In Program Mode, the five Switch buttons are pre-assigned to change the sound in different ways, for example enabling layers or effects.

In Multi Mode, you can assign the Switch buttons to control Program and effects parameters, or send MIDI CC messages to external equipment.

The Switch Button LEDs illuminate red when the switch is active.

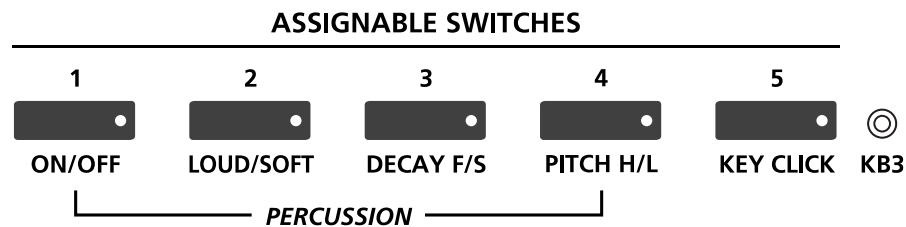

Foot Switches and Controllers

The Artis has sophisticated Pedal controller options allowing up to 4 Switch Pedals or up to 2 Half Damper Pedals as well as a Continous Controller Pedal to be connected. By default the Switch Pedals control SW1a - Sustain, SW1b - Sostenuto, SW2a - Sostenuto and SW2b - Soft. The CC Pedal control expression by default.

All of these Pedals can be reassigned in Global Mode to a range of different parameters, that will work in Program Mode and act as defaults in Multi Mode.

KB3 Buttons

For KB3 Programs, these buttons manipulate the KB3 sound, as per the blue labels below the button. When the LED of the button is red, the KB3 function is active.

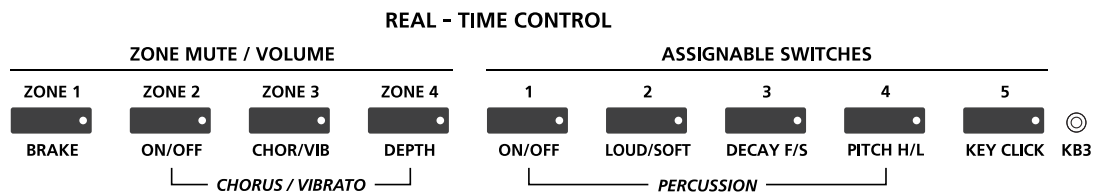

Transpose & Variation Buttons

The Transpose and Variation buttons are located at the very end of the left side of the Artis keyboard, just above the Pitch & Modulation Wheels.

On the Artis7, the Transpose buttons are located to the left of the LCD display beside the Soft buttons. The Variation button is located just above the Modulation Wheel.

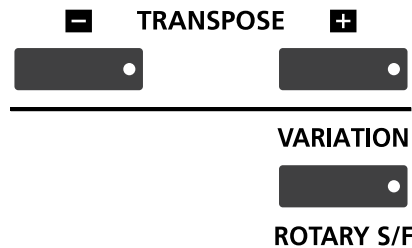

Transpose

The Transpose buttons can be used to change the tuning of notes played on the Artis keyboard in semitones (ST), also known as half steps. This is a convenient way to change the key of a song without learning to play it in a different key. The Transpose buttons are located to the left of the keyboard, above the Pitch and Mod Wheels. The Transpose buttons also transpose MIDI notes sent to the USB and MIDI out ports.

Press the Transpose - or + buttons to transpose the Artis keyboard down or up by one semitone. The top line of the display shows the current transposition value. Pressing both Transpose - and + simultaneously will reset the transposition to 0. To transpose up and down by octave intervals (12 ST), press the Octav- and Octav+ soft buttons underneath the display.

The maximum transposition value possible is ± 36 semitones.

The LEDs of the Transpose buttons indicate whether the current Program is transposed up (Transpose + LED is lit) or transposed down (Transpose - LED is lit). When there is no transposition, neither Transpose button is lit.

Variation

The Variation Button is a MIDI controller (default MIDI CC#29) that is programmed in most Programs to modify the sound, such as adding a pad sound, changing the effects or some other variation suited to changing with a switch.

For KB3 programs, the Variation Button controls the Rotary Speaker speed, switching between fast and slow.

Master EQ

The Master EQ allows you to have realtime control over the frequency response of all audio generated in either Program or Multi Modes. When the Master EQ On/Off button is “On”, the rotary knobs can change the high , middle & low frequencies of the audio.

If the LED on the Master EQ On/Off button is lit, this indicates that the Master EQ section is now “on”.

The HI & LOW EQ’s are shelving type filters, and the MID has an adjustable center frequency with a range of approximately 2 octaves up and down centered around approximately 1.4 kHz

	Frequency	Gain
HI	~6.6 kHz	-24dB to +15dB
MID*	~1.4 kHz	-24dB to +15dB
LOW	98 Hz	-24dB to +15dB

* center of range

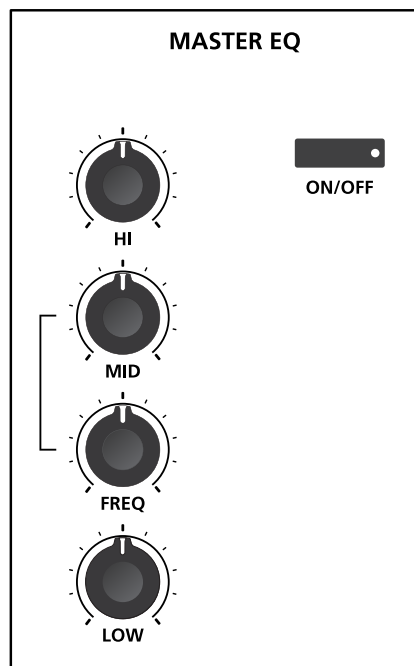

When the Master EQ is on, the audio signal flows as per the diagram above. When it is off, the signal flows as per the digram below.



Save Button

The Save button is located beneath the “Save” label on the left side of the LCD screen.



In Program Mode, pressing the Save button saves the current position of the sliders, switches and wheels as a User Program. (See Save and Delete User Programs on page 6-18.)

In Multi Mode, pressing the Save button saves a copy of the current Multi. The copy is saved with the states of the Multi Zone Mute buttons but does not include the current state of the physical controllers (i.e. moved Sliders, Mod Wheel etc.). Other controller states can be edited in Multi Edit Mode. See Save and Delete User Multis on page 7-12.

The Save button’s LED is illuminated once you have made changes to the current Program or Multi to indicate that the Program or Multi has changed.

Audio In

On the back panel of the Artis you will find a 1/8" sized stereo audio jack labelled AUDIO IN.

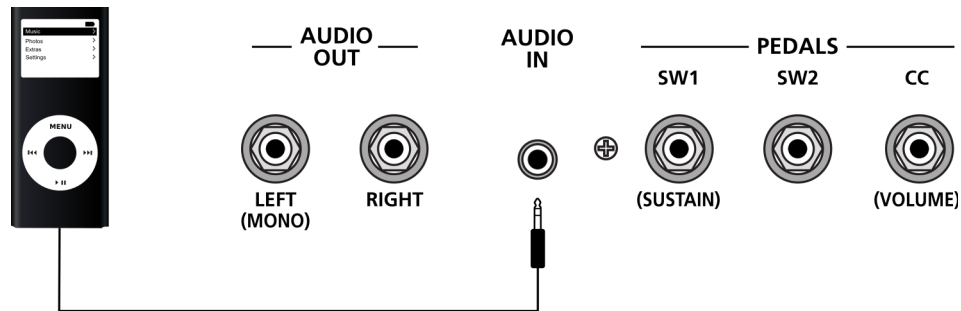

You can plug your MP3 player into the Artis and play along with the recorded music. There is no volume control for the Audio Input on the Artis itself, so you should control the mix volume of the Audio Input from the MP3 player itself.

Mode Buttons

The Mode buttons are located beneath the “Mode” label on the right side of the Artis front panel.

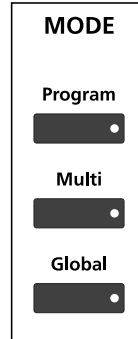

Program Button

Pressing the Program button enters Program Mode (described in Program Mode on page 5-1 and, in further detail, in Program Mode on page 6-1). In Program Mode, you can select and play different sounds (or “Programs”). This button’s LED is illuminated when you are in Program Mode. Program Mode is the default Mode — the Artis always boots up in this Mode.

Multi Button

Pressing the Multi button enters Multi Mode (described in Multi Mode on page 5-2 and, in further detail, in Multi Mode on page 7-1). In Multi Mode, you can select different configurations of Programs, controller assignments, and MIDI channel assignments.

This button’s LED is illuminated when you are in Multi Mode.

Global Button

Pressing the Global button enters Global Mode (described in Global Mode on page 5-2 and, in further detail, in Global Mode on page 9-1). In Global Mode, you can edit parameters that control the overall behavior of the Artis. These parameters include tuning, transposition and velocity. Additionally, you can save or load user Programs and Multis to and from a computer connected to the Artis via USB as well as perform a Hard/Soft Reset. This button’s LED is illuminated when you are in Global Mode.



CAUTION: Performing a Hard Reset will erase ALL User Program and User Multis, and will reset Global settings to a factory state.

Navigation

The navigation section of the Artis front panel includes the LCD display, Previous & Next buttons, Param / Channel buttons, and the Alpha Wheel.

The Display Contrast knob is easily located, above the Alpha Wheel.

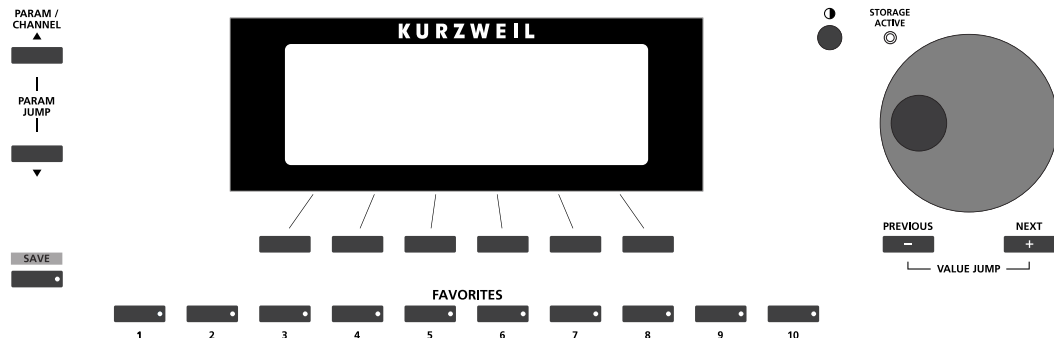

The LCD Display

In Program and Multi Mode, the top line of the display shows the current Mode, MIDI transposition, Category name (with Program number of that Category) and MIDI channel (Program Mode only). The middle line in large text shows the current Program or Multi ID number and name.

In Multi Edit Mode, the top line of the display shows the current mode, page name, Zone number (except for the Common Page, which is common to all Zones), the current parameter number and the total number of available parameters.

In Global Mode, the top line of the display shows the current mode and page name.

The bottom line of the display shows the names of the Soft Buttons for the current page.

Previous (-) and Next (+) Value Buttons

Use the Previous and Next buttons to scroll through the list of values for the currently selected parameter. Pressing both the Previous and Next buttons simultaneously is referred to as the Value Jump double button press. Depending on the selected parameter, Value Jump can select the next Category default Program/Multi, jump to commonly used values, and reset parameters to default values. For more information, see Value Jump on page 3-14.

Param / Channel Buttons

In Program Mode, pressing the Param / Channel Up button will change the MIDI transmit channel from the current channel to the next one; pressing the Param / Channel Down button will change the MIDI transmit channel from the current channel to the previous one.

Features of the Artis

Navigation

When the highest or lowest MIDI transmit channel is reached, the list will wrap back to the last or first MIDI transmit channel respectively. The top line of the display shows the current MIDI transmit channel.

In the other Modes—Multi Edit & Global—pressing the Param / Channel buttons will scroll through the parameter list for the current Mode.



NOTE : The Param / Channel buttons are not used in Multi Mode.

Alpha Wheel

Use the Alpha Wheel to scroll through the list of values for the currently selected parameter—turning the Alpha Wheel counter-clockwise will select the previous value and turning the Alpha Wheel clockwise will select the next value. You can turn the Alpha Wheel slowly to change the value by one increment or turn it quickly to jump several increments.

Display Contrast Knob

You can adjust the display contrast by turning this small potentiometer knob.

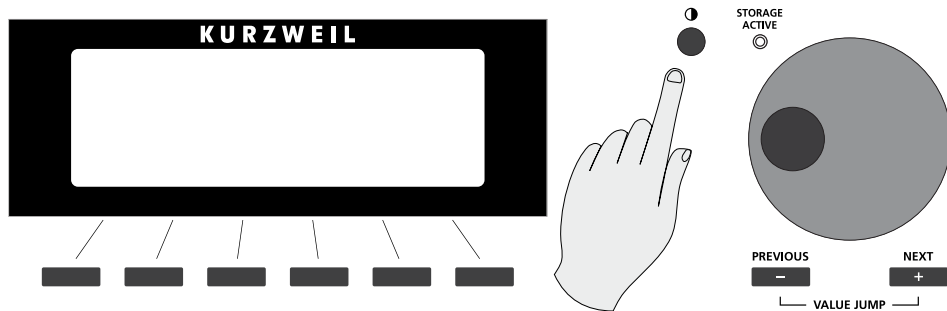

Sound Select

The Sound Select section allows you to quickly and easily get access to sounds in either Program or Multi Modes. You select the Category of sound you want, then via the Program / Multi select any of the 16 sounds in that Category.

CATEGORY

The Artis makes it easy to select sounds by instrument type. The 16 Category buttons are clearly labelled for you to choose easily. If a Category button is lit, you are currently in that selected Category.

PROGRAM / MULTI

When a Category has been selected in Program or Multi Mode, you can select any of the 16 sounds of that Category. The Program/Multi buttons are numbered from 1 to 16 to make the selection easy.

The white print on each of these buttons indicates their secondary alphanumeric functions when used for data entry.

SOUND SELECT

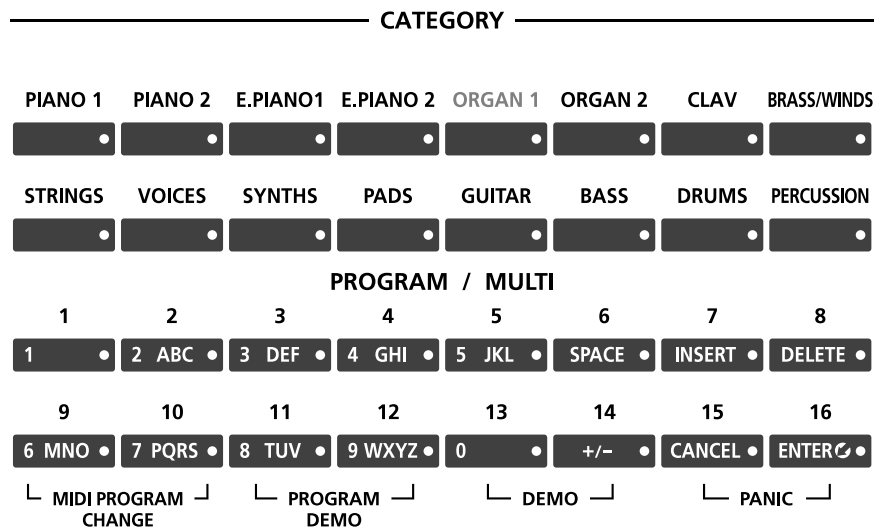

KB3 LED

The KB3 LED is on the right side of the Assignable Switches.

If the currently selected Program is a KB3 program, the KB3 button's LED is lit. This indicates that the front panel KB3 controls (printed in blue) are active.

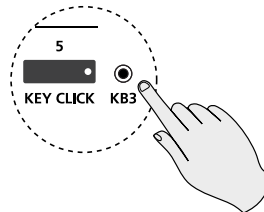

Double Button Presses

Several pairs of the buttons on the Artis have timesaving secondary functions when pressed simultaneously—think of them as keyboard shortcuts. For convenience of reference, descriptions of all of the double-button press functions appear below.

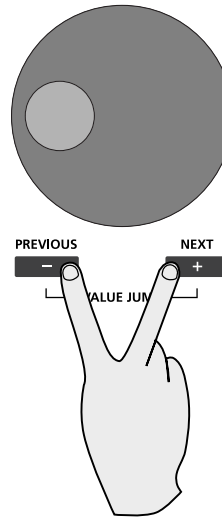

Value Jump

In Program Mode, the Value Jump double button press selects the first Program of each Category, as well as the Category Default Program of each Category (if a Category Default Program has been set).

For more information on choosing a new Category Default Program, see Choosing Category Default Programs on page 6-6.

In Multi Mode, the Value Jump double button press selects the first Multi of each Category, as well as the Category Default Multi of each Category (if a Category Default Multi has been set).

In Multi Edit Mode, pressing the Value Jump double button press resets the current parameter to its default value, or jumps between multiple useful values.

Parameter Jump

In Multi Edit Mode, pressing both the Param / Channel Up and the Param / Channel Down buttons simultaneously will jump to a specific parameter depending on the currently selected page.

In Program Mode, pressing the Parameter Jump double button press allows you to change the current MIDI channel by using the Program/Multi Select buttons.

On the Global Mode MASTER and MIDI pages, pressing the Parameter Jump double button press jumps to selecting the first parameter in the list.

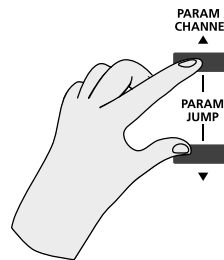

Reset Transposition

Pressing both Transpose + and Transpose - , or Octave + and Octave - (Soft Buttons) simultaneously will restore the current Program or Multi to having no transposition.



Features of the Artis

Double Button Presses

MIDI Program Change

Pressing the 9 & 10 Program/Multi buttons enters the MIDI Program Change Function Page (described in further detail page 5-4). With the MIDI Program Change Function, you can send a MIDI Program Change message to any sound module in a MIDI chain connected to the Artis.

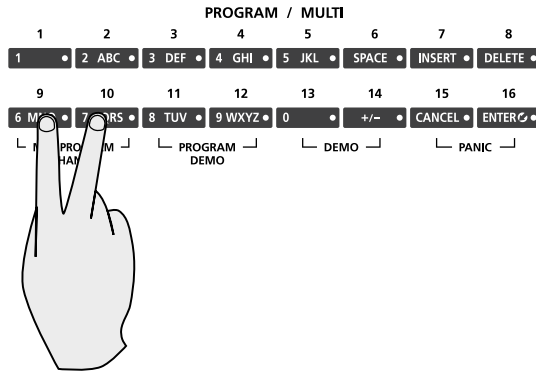

A label below the 9 & 10 Program/Multi buttons indicates the MIDI program change double button press.

Program Demo

In Program Mode only, pressing the 11 & 12 Program/Multi buttons performs the Program Demo Function. The Program Demo Function plays the Demo Song for the currently selected Program.

If you press these buttons from any other Mode, the display will give you a message indicating you are not in Program Mode. Press the Cancel soft button to exit the Program Demo.

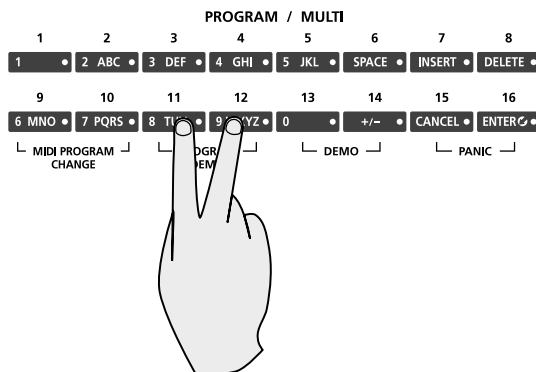

A label below the 11 & 12 Program/Multi buttons indicates the Program Demo double button press.

Demo

Pressing the 13 & 14 Program/Multi buttons performs the Demo Function (described in further detail in Demo Function on page 5-6). With the Demo Function selected, you can hear a demonstration Song that showcases many of the features of Artis.

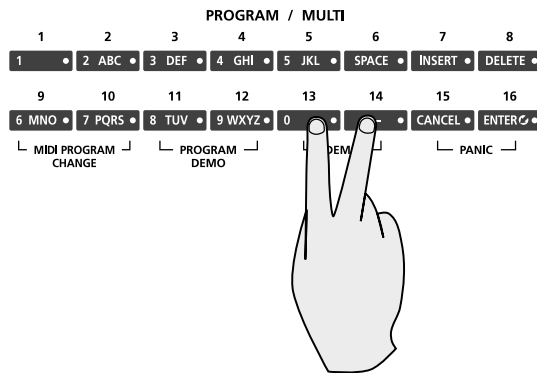

A label below the 13 & 14 Program/Multi buttons indicates the Demo double button press.

Panic

Pressing the 15 & 16 Program/Multi buttons simultaneously deactivates all sounding notes and control messages and sends an “all notes off” message and an “all controllers off” message on all 16 MIDI channels.

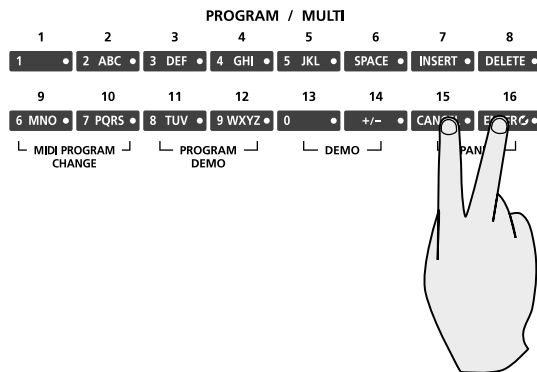

A label below the 15 & 16 Program/Multi buttons indicates the Panic double button press.

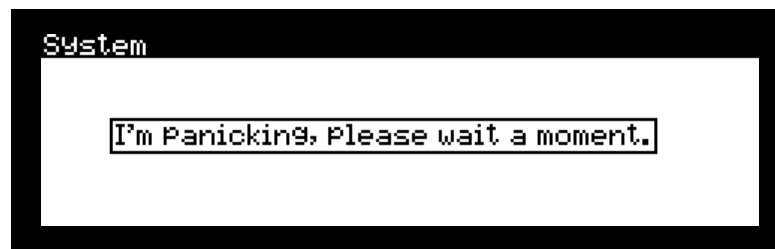

Features of the Artis

Double Button Presses

Assign

Assign is the secondary function of the Enter button.



The Assign symbol will be shown in the display next to parameters that can be selected with Assign.



Pressing a key, switch, or moving a controller while holding down the Enter button will perform Assign in the following cases.

Enter + Zone (1–4) Button

In Multi Edit Mode, holding the Enter button and pressing a Multi Zone Mute button will jump to selecting that Zone. The currently selected Zone number can be seen on the top line of the page.

Enter + Controller

In Multi Edit Mode, holding the Enter button and moving a controller (a Slider, Switch button, Mod Wheel or Pedal) will jump to selecting the destination parameter of that controller in the current Zone. This allows you to quickly assign a controller to a destination.

In Multi Edit Mode, holding the Enter button and moving the Pitch Wheel up or down will jump to selecting the Bend Range Up or Bend Range Down parameters of the current Zone.

Enter + Key

In Split Mode with the Split Key parameter selected, hold the Enter button and strike a key to select the Split Key.

In Multi Edit Mode with the Low Key or High Key parameter selected, hold the Enter button and strike a key to select the Low Key or High Key.

Chapter 4

Terminology

This chapter provides definitions and descriptions for all of the Artis-specific terms used in this manual. Some of the terms are also used by other manufacturers.

Since there are no standard definitions for some of these terms, they are described here to avoid confusion. All of these terms appear with the first letter capitalized as proper nouns in this manual to make it easy to distinguish between the generic term and the Artis specific term.

In addition to the terms below, and to avoid confusion, any Artis specific feature, connector or control will have the first letter capitalized to distinguish it from the generic term.

Program

A Program is an instrument sound that plays on a MIDI channel. The sound of each Program can be modified by parameters that are assigned to the controllers (Sliders, Switch buttons, Mod Wheel, and Pedals).

See Program Mode on page 6-1 for more information on Programs.

Multi

A Multi allows up to 4 instrument sounds (Programs) to be played from the keyboard at once. A Multi has 4 Zones, each with its own keyboard range, Program, MIDI channel, and controller assignments.

See Multi Mode on page 7-1 for more information on Multis.

Terminology

KB3	Kurzweil's organ modeling simulation of classic tone wheel organs with rotary speaker emulation.
Zone	<p>A keyboard region of a Multi that has its own Program, MIDI channel, and controller assignments.</p> <p>See About Zones on page 7-6 for more information on Zones.</p>
Split	<p>A Split is a Multi containing at least two Zones that have keyboard ranges that don't overlap. This allows different keyboard ranges to play different instrument sounds.</p> <p>See The Split Function on page 7-8 for more information on Splits.</p>
Layer	<p>A Layer is a Multi containing at least two Zones that have overlapping keyboard ranges. This allows a single keyboard range to play multiple instrument sounds.</p> <p>See The Layer Function on page 7-10 for more information on Layers.</p>
MIDI Bank	A group of 128 Programs that can be navigated by MIDI compatible software or hardware.
Mode	<p>An operating status with a unique group of operations.</p> <p>See The Operating Modes on page 5-1 for more information on Modes.</p>
Pressure	Pressure applied to keys after a note is struck. It is also known as aftertouch, channel pressure or mono pressure in other keyboards.

Hard Reset

A process that returns Artis back to a Factory state. All User Programs & User Multis are erased. All Global Mode parameters are reset back to their default settings as well.

Soft Reset

A process that resets all Global Mode parameters to their default factory settings. User Programs & User Multis are not erased.

Object

Anything that can be named, saved, deleted, or edited (i.e., a Program or a Multi).

KUF file

KUF (Kurzweil Unified File) file is a special file that has the objects and operating system combined that is used to update the Artis.

Chapter 5

The Operating Modes

This chapter will help familiarize you with the operating Modes of the Artis.

Each of the four Modes (Program, Multi, Multi Edit, Global) has its own individual chapter. The four Functions (Split, Layer, MIDI Program Change, and Demo) are described in this chapter in Functions on page 5-3.

Program Mode

Program Mode is the default Mode for the Artis.

In Program Mode, instrument sounds (Programs) can be selected and played. The sound of each Program can be modified by parameters that are assigned to the controllers (Sliders, Switch buttons, Mod Wheel, and Pedals). Modified Programs can be saved as User Programs by pressing the Save button.

To enter Program Mode from another Mode, press the Program Mode button.

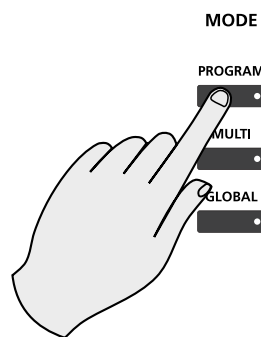

For more detailed information on Program Mode, see Program Mode on page 6-1.

The Operating Modes

Multi Mode

Multi Mode

Multi Mode allows you to select and play Multis.

A Multi allows up to 4 instrument sounds (Programs) to be played from the keyboard at once. A Multi has four Zones, each with its own keyboard range, Program, MIDI channel, and controller assignments. To enter Multi Mode from another Mode, press the Multi Mode button.

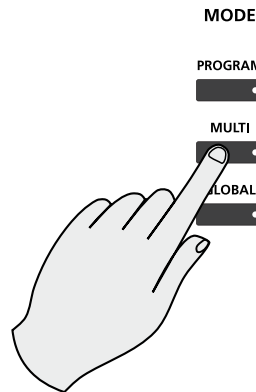

For more detailed information on Multi Mode, see Multi Mode on page 7-1.

Global Mode



CAUTION: THIS MODE CONTAINS CERTAIN OPERATIONS THAT CANNOT BE UNDONE. Read Global Mode on page 9-1

Global Mode allows you to edit global parameters and MIDI settings, load and save User Programs and Multis, or restore factory defaults with a hard reset. To enter Global Mode from another Mode, press the Global Mode button.

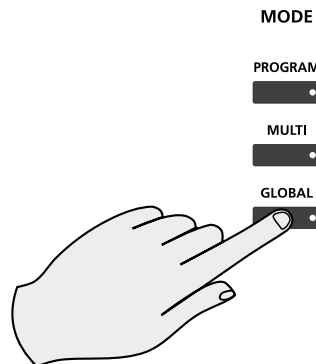

Functions

In addition to the four primary Modes, there are five Functions. Some Functions are available through dedicated buttons, others are available as Soft Buttons accessed via the buttons under the LCD screen. These Functions are not as complex as the primary Modes and are described below.

The Split Function

Pressing the Split Soft Button while in either Program or Multi Mode performs the Split Function. The Split Function allows you to split Programs and Multis such that keys in one region of the keyboard produce different sounds than another region.

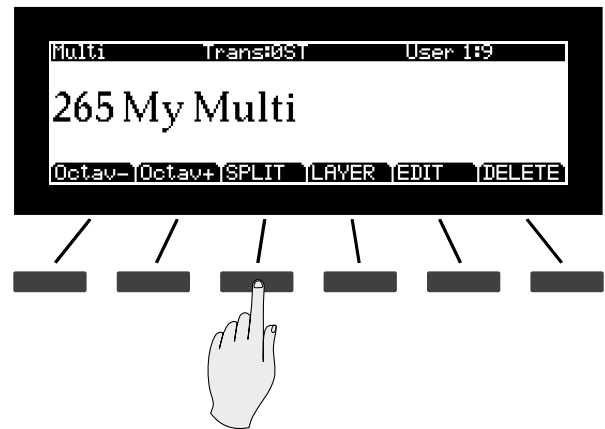
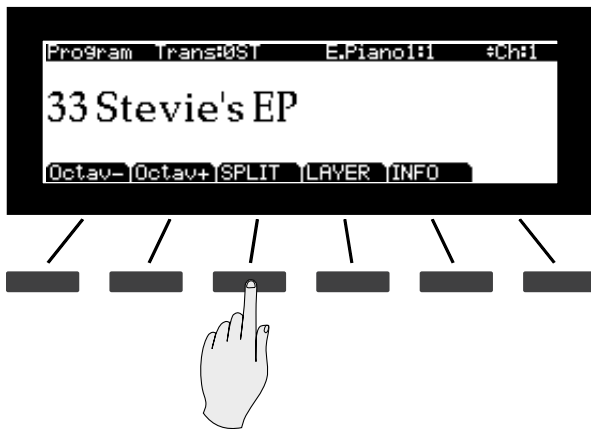

Creating Splits in Program Mode is slightly different from creating Splits in Multi Mode. See The Split Function on page 6-9 (for Splits in Program Mode) and The Split Function on page 7-8 (for Splits in Multi Mode).

The Layer Function

Pressing the Layer Soft Button while in either Program or Multi Mode performs the Layer Function. The Layer Function allows you to layer Programs and Multis such that more than one sound can be produced by striking one key.

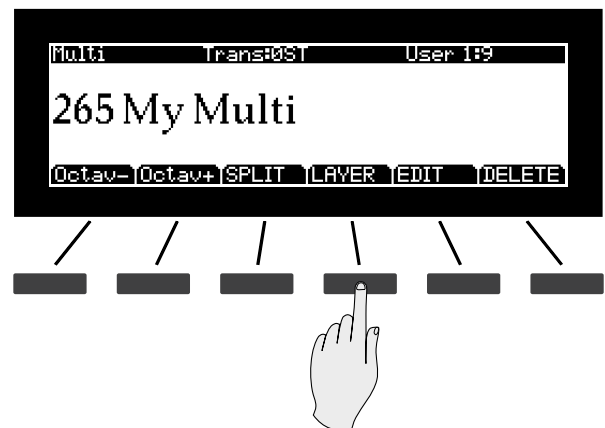
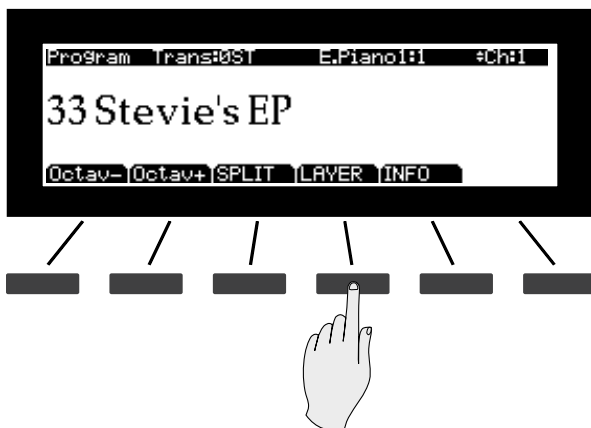

The Operating Modes

Functions

Creating Layers in Program Mode is slightly different from creating Layers in Multi Mode. See The Layer Function on page 5-3 (for Layers in Program Mode) and The Layer Function on page 7-10 (for Layers in Multi Mode).

MIDI Program Change Function

Pressing both the 9 & 10 Program/Multi buttons simultaneously takes you to the MIDI Program Change Function page.

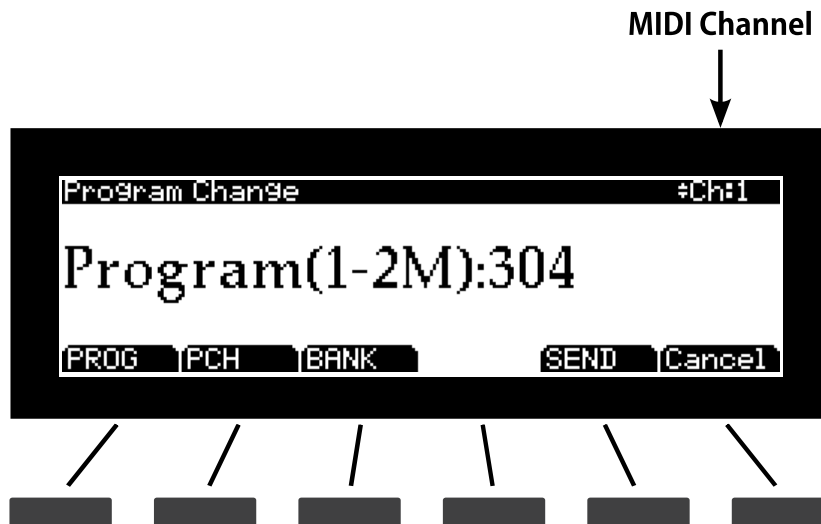
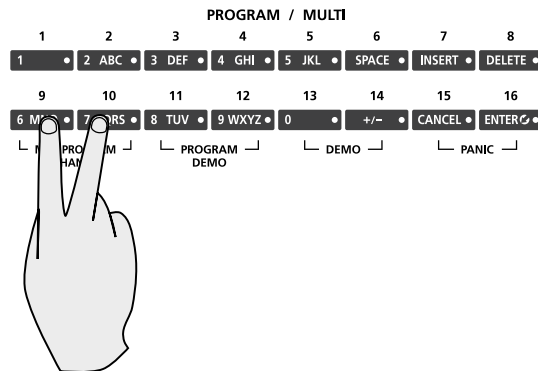

With this Function, you can use a MIDI or USB cable to send a MIDI Program Change message to an external sound module or computer software. MIDI Program Change messages allow you to use the Artis to change presets on other MIDI equipment. Doing so will not affect the local sound (that is, it will not affect the currently selected Program on the Artis). Your external MIDI device may have program change receive settings to configure.

The MIDI Program Change Function has three pages, PROG (Program), PCH (MIDI Program), and BANK (MIDI Bank). Use the PROG, PCH, or BANK soft buttons to access each page. By default the Program page is selected when entering the MIDI Program Change Function. Use the Param/Channel buttons to the left of the display to change the MIDI channel that you wish to send a program change to (MIDI channel is shown in the top right of the display).

PROG (Program)

Use the Program page if you wish to send a program change message to another Artis, or to a sound module that has programs starting at Program 1 that are not organized into banks each numbered 1 - 128. Press the PROG soft button if you are not already viewing the Program page.

Use the numbers printed on the Program/Multi buttons to enter a Program number, then press the Enter button. Press the SEND soft button to send the MIDI program change, or press the Cancel soft button to return to the previous Mode. After the Program Change is sent, the Artis will return to the previous Mode. On the Program page you can enter Program numbers from 1 to 2,097,152—this seemingly random number comes from the fact that, by the MIDI Specification, you can send Program messages for up to 16,384 MIDI Banks (0–16,383), each containing up to 128 Programs.

PCH (MIDI Program) & BANK (MIDI Bank)

Use the MIDI Program and MIDI Bank pages if you wish to send a program change message to a sound module that has Programs organized in MIDI Banks of 128 Programs. Follow these steps:

1. Press the PCH soft button to go to the MIDI Program page. Use the numbers printed on the Program/Multi buttons to enter a Program number, then press the Enter button. (If the Programs on your connected sound module are organized with each Program number being between 1 and 128, then first subtract 1 from the desired Program number before pressing the Enter button.)
2. Press the BANK soft button to go to the MIDI Bank page. Use the numbers printed on the Program/Multi buttons to enter a Bank number, then press the Enter button.
3. Press the SEND soft button to send the MIDI program change, or press the Cancel soft button to return to the previous Mode. After the Program Change is sent, the Artis will return to the previous Mode.

The Operating Modes

Functions

Demo Function

Pressing the 13 & 14 Program/Multi buttons simultaneously performs the Demo Function.

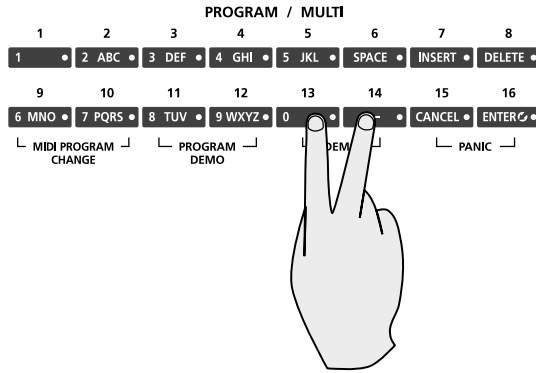

Use the Demo Function to play built-in Demo Songs designed to demonstrate the capabilities of the Artis.

While using the Demo Function, the top line of the display shows the text “Demo”, the Demo number, and the total number of available Demos. The center of the display shows the ID number and name of selected Demo Song. Use the Alpha Wheel, Value buttons or the Param/Channel Up or Down buttons to select another demo from the list. The 13 & 14 Program/Multi button LEDs blink when using the Demo Function.

Press the Cancel Soft Button to exit the Demo Function.

Program Demo Function

Pressing the 11 & 12 Program/Multi buttons simultaneously performs the Program Demo Function.

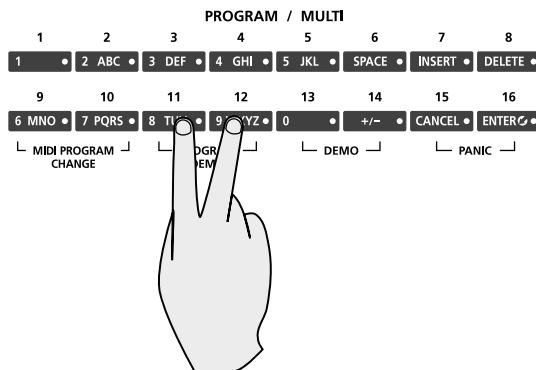

In Program Mode, use the Program Demo Function to play a built-in Demo Song that demonstrates the selected Program. The 11 & 12 Program/Multi button LEDs blink when using the Program Demo Function.

Press the Cancel soft button to exit the Program Demo Function.

Multi Edit Mode

Multi Edit Mode allows you to edit pre-existing Multis.

To enter Multi Edit Mode press the Edit Soft Button while in Multi Mode.

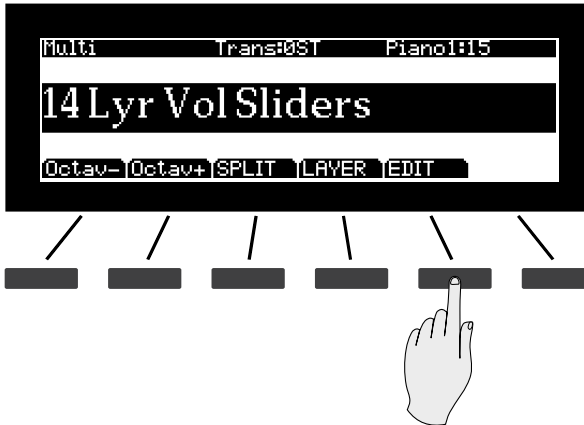

For more detailed information on Multi Edit Mode, see Multi Edit Mode on page 5-7.

The Operating Modes

Multi Edit Mode

Chapter 6

Program Mode

This chapter will help familiarize you with the features of Program Mode.

Programs are essentially the different sounds of a MIDI instrument—they are preset instrument sounds equivalent to the “patches,” “presets,” or “voices” that you find on other keyboards.

About Program Mode

Program Mode is the default Mode of the Artis. It will always boot up in this Mode.

To enter Program Mode from another Mode, press the Program Mode button. While you are in Program Mode, the Program button’s LED is illuminated.

The Artis starts up with the default Program in the Piano1 category selected, either Program 1 (factory default) or a Program you pick as a Category Default Favorite for the Piano1 category, see Choosing Category Default Programs on page 6-6.

If you enter Program Mode from another Mode, the current Program will be the last selected Program on the current MIDI Channel.

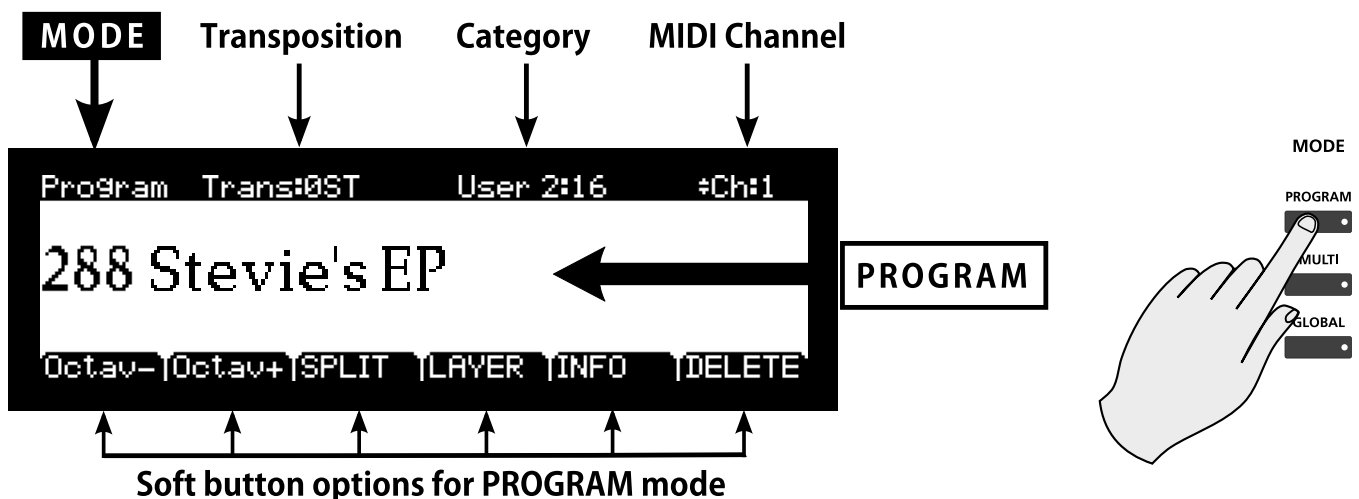

Program Mode

Selecting Programs

Selecting Programs

The Artis features two Program Banks, one of which contains 256 factory Programs, and the other Bank is reserved for up to 256 User Programs. Both the factory and User Banks are split into 16 categories of 16 Programs each.

When you are in Program Mode, there are a few ways to select Programs.

- To select a Program in the current Category, press the relevant Program/Multi button.
- To select a Program in a different Category, press the Category button of choice and then a Program/Multi button to select from the 16 Programs in the Category.
- To select the default Program from a Category, simply press the relevant Category Button.
- Choosing a Program in the user Categories, while in the factory Categories, or choosing a Program in a factory Category while in a user Category, requires pressing the User button, followed by a Category button and then a Program/Multi button.
- The Alpha Wheel and the Next and Previous buttons allow you to advance through the Programs one at a time. When you reach the end of the Category, advancing further will go the the next Category.
- If a Program is assigned to a Favorite Button, pressing that button will go directly to the assigned Program.

Program Demo

If you want to quickly hear what a Program sounds like, try the Program Demo Function.

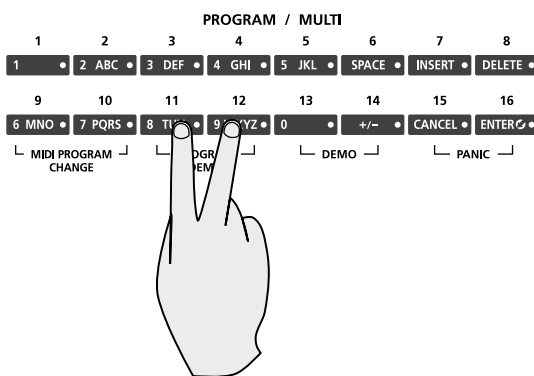

In Program Mode only, pressing the 11 & 12 Program/Multi buttons performs the Program Demo Function. The Program Demo Function plays a Demo Song for the currently selected Program.



Press the Cancel soft button to exit Program Demo.

If you try to use the Program Demo Function from any other Mode, the display shows the “Switch to Program Mode first” message.

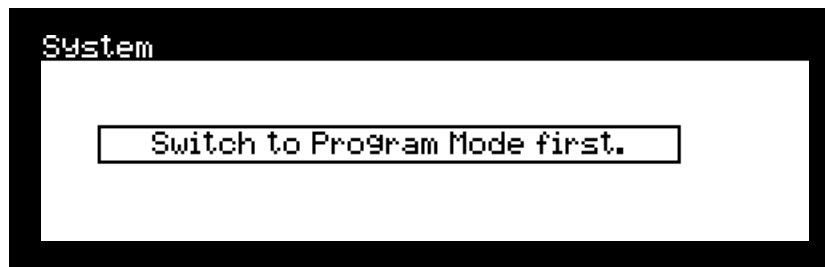

The Display

In Program Mode, the top line of the display shows the current Mode, MIDI transposition, Category and MIDI Channel. The Program ID number and name are displayed in the center of the display, and the Soft Buttons are displayed along the bottom line.

Factory Program Categories on the top line correspond with the labels above of the Category Buttons. For User Programs, the Categories are labelled User 1, User 2 ... User 16.

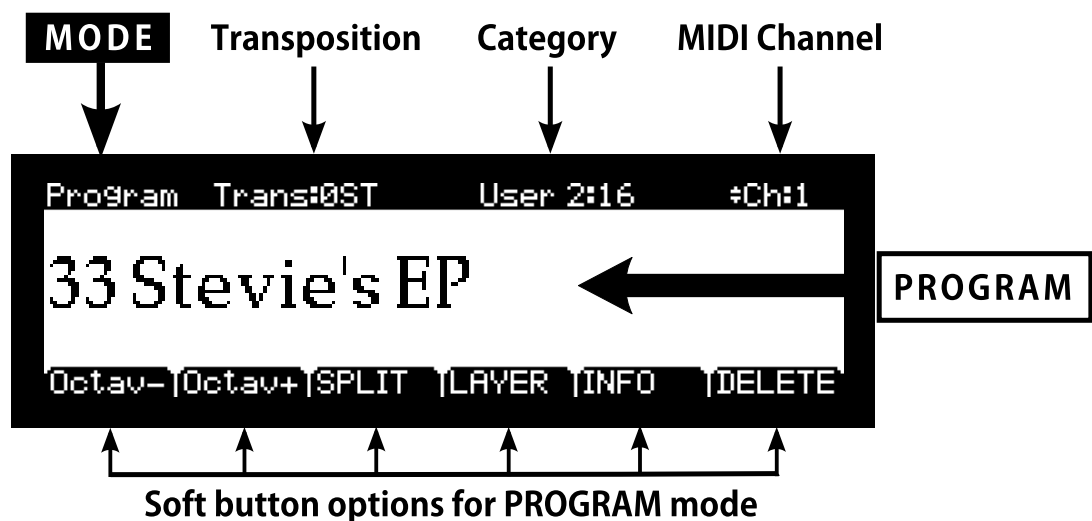

Program Mode

Selecting Programs

Pop Up Messages

Some actions cause the display to show pop up messages. After a short time the display returns to show the current Program.

Alpha Wheel & Previous (-) and Next (+) Value Buttons

Use the Alpha Wheel or the Previous (-) and Next (+) buttons, to the right of the display below the Alpha Wheel, to change the current Program. Turning the Alpha Wheel counter-clockwise or pressing the Previous button will select the previous Program and turning the Alpha Wheel clockwise or pressing the Next button will select the next Program. When the highest or lowest Program is reached, the list will wrap back to the last or first Program respectively.

When scrolling through the Program list, the list moves through each Category, both factory and User.

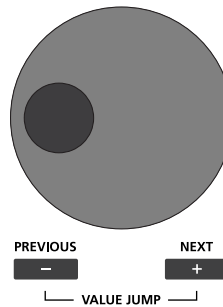

Value Jump Buttons

In Program Mode, the Value Jump double button press selects the first Program of each Category, as well as the Category Default Program of each Category (if a Category Default Program has been set).

For more information on choosing a new Category Default Program for each Category, see Choosing Category Default Programs on page 6-6.

If the User button is selected, Value Jump works the same way.

Category & Program/Multi Buttons

The Category buttons allow you to select Programs by instrument type simply by pressing a button. You can select one Category button at a time and the current Category button's LED is lit.

SOUND SELECT

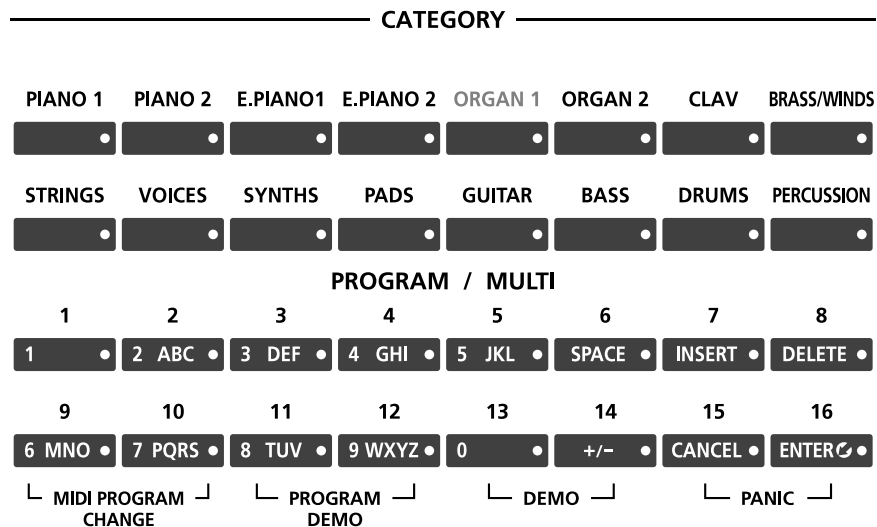

Each Category contains 16 Programs of a single instrument type. First select the Category you want, then select one of the 16 Programs by pressing any of the Program/Multi buttons numbered from 1 to 16.

You can also press one of the instrument Category buttons, then turn the Alpha Wheel clockwise or press the Next button to advance to the next Program in the Category. When you reach the end of a Category, the Artis automatically advances to the beginning of the next Category. This will also work in reverse if you turn the Alpha Wheel counter-clockwise or press the Previous button. In this case when you reach the beginning of a Category, Artis automatically advances to the end of the previous Category. The 16 User Categories come after the factory ones, but only non-empty programs can be selected this way.

Choosing Category Default Programs

You can choose a “Category default program” from each Category that will be recalled each time you press that Category’s button. To save a Category default program, first select a Program using any Program select method (Alpha wheel, Previous/Next buttons, Category buttons, Program/Multi buttons). A Category button for the current Category will have a lit LED. Next, press and hold the currently lit Category button until the display shows the message “Category default program saved.” The Category default program has now been successfully saved.

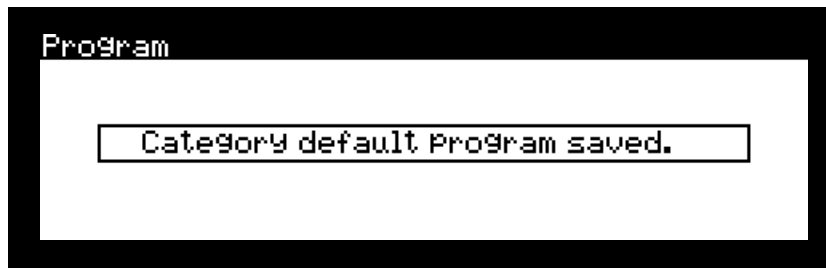

You can only save a Program as a Category default for the Category that it belongs to. If you try to save a Category default program to a different Category, you will see the following pop up message in the display.

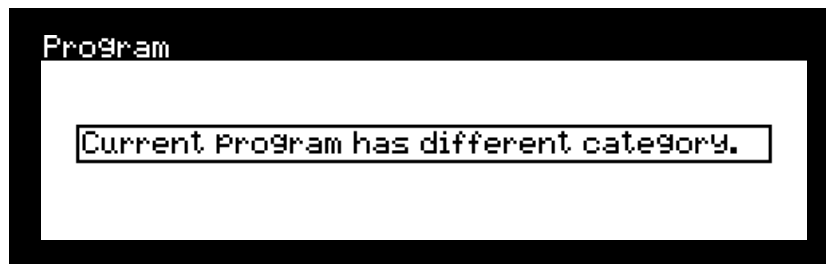

Choosing Favorites

You can save ten Favorite Programs (or Multis) from any Category to the ten Favorite Buttons beneath the display. Once saved, these favorite Programs can be recalled from any Mode with a single button press. To save the currently selected Program to a Favorite Button, press and hold a Favorite Button until the display shows the message “Program saved to favorite button.”

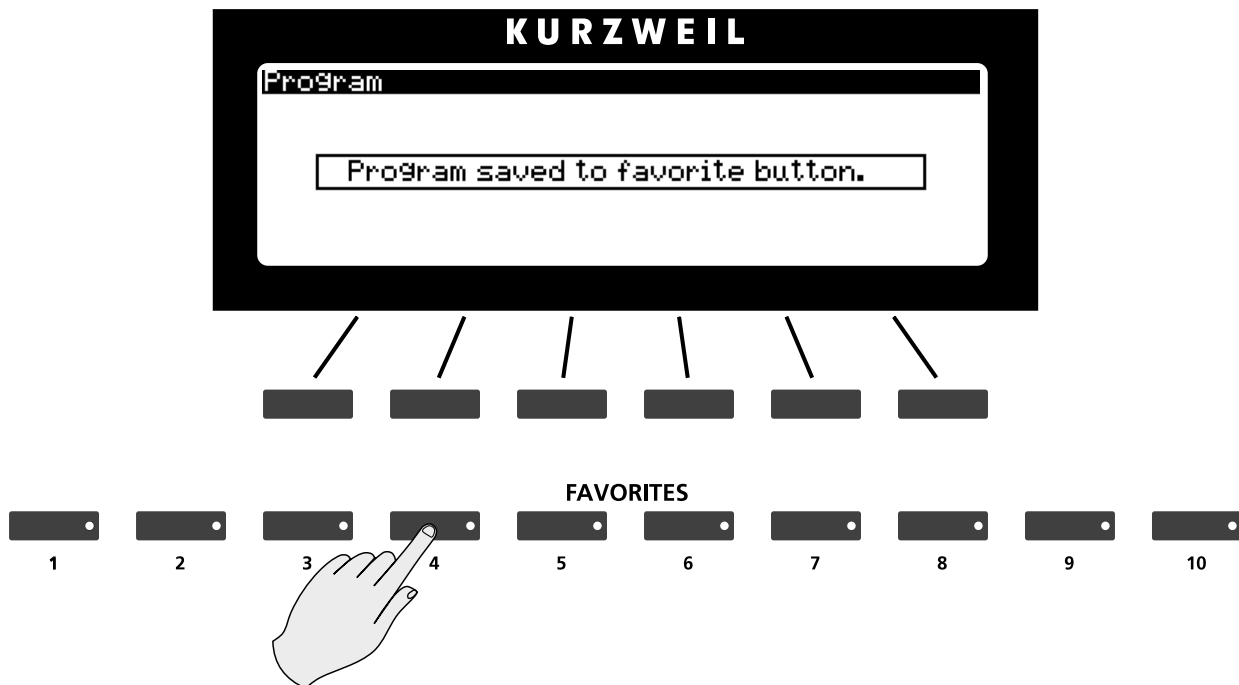

Transposition

The Transpose buttons can be used to change the tuning of notes played on the Artis keyboard in semitones (ST), also known as half steps. This is a convenient way to change the key of a song without learning to play it in a different key. The Transpose buttons are located to the left of the keyboard, above the Pitch and Mod Wheels. The Transpose buttons also transpose MIDI notes sent to the USB and MIDI out ports.

Press the Transpose - or + buttons to transpose the Artis keyboard down or up by one semitone. The top line of the display shows the current transposition value. Pressing both Transpose - and + simultaneously will reset the transposition to 0. To transpose up and down by octave intervals (12 ST), press the Octav- and Octav+ soft buttons underneath the display.

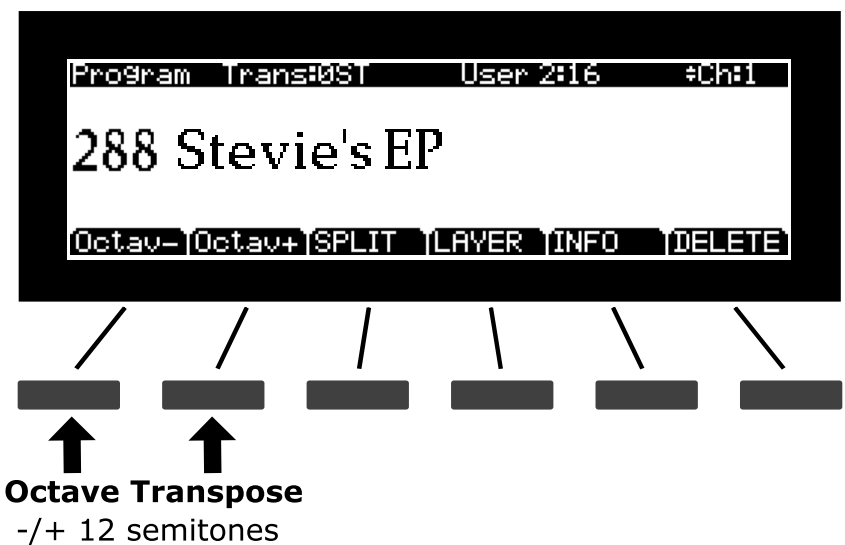
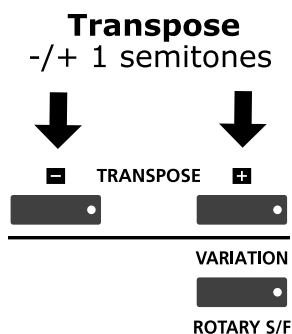

The maximum transposition value possible is +/-36 semitones.

The LEDs of the Transpose buttons indicate whether the current Program is transposed up (Transpose + LED is lit) or transposed down (Transpose - LED is lit). When there is no transposition, neither Transpose button is lit.

Parameter Assignments

In Program Mode, each Program has factory set Program and Effect parameters assigned to physical controllers (Sliders, Switch buttons, Mod Wheel, and Pedals). A parameter assignment can modify an instrument sound during a performance to add variation or expression. Moving a controller changes the value of the parameter. Any time you do this, the display shows the Controller name, assigned parameter, and value. In Program Mode you can also press the INFO soft button to see a list of controllers and assignments.

For most programs, Slider A is assigned to a filter or EQ parameter in order to control brightness. Slider I controls reverb amount in all Programs, while Slider H usually controls a second effect, such as delay/echo amount. The Variation button often enables an effect or additional Program layer. The remaining controls have different assignments depending on the selected Program.

If you make changes to the current Program using any of the controllers, the Save button's LED lights to indicate that a change has been made to that Program. For more information on the Save button, see Save and Delete User Programs on page 6-18.



The Split Function

Pressing the Split soft button while in Program Mode will perform the Split Function. The Split Function allows you to split Programs such that keys in one region of the keyboard produce different sounds than another region.

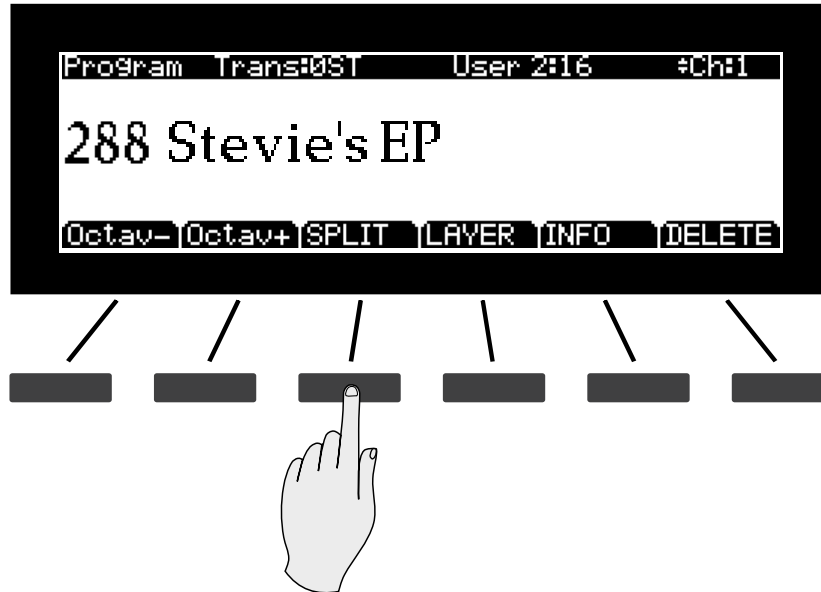

When you create a Split in Program Mode, you are in fact creating a Multi with two active Zones (see Multi Mode on page 7-1, for more information on Multis). As previously described, Multis are configurations of four Zones, each of which may have its own Program and controller assignments.

The Split Function is convenient, as you do not need to use Multi Edit Mode to configure Zone key ranges, Programs, and volumes. You can simply hit the Split button, and the Artis automatically creates a Multi with two active Zones. The Program you were using in Program Mode is used in the right hand of the Split as the Program for Zone 1. After this you can choose a “Split Program” that will be used in the left hand of the Split as the Program for Zone 2.

Once you have saved your Split as a Multi, you can continue to add Split or Layer Zones to the Multi until you reach the maximum of four active Zones. The Artis will display a message if you have already reached the maximum of four active Zones (see Multi Mode on page 7-1, for more information on Multis).

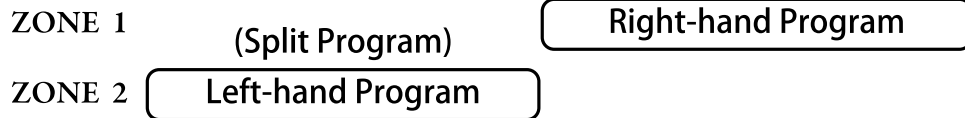

There are four parameters (described below) that determine the behavior of the Split. Press one of the four soft buttons on the bottom left of the display to access each of the Split parameters.

Prog (Split Program)

Press the PROG soft button to change the Prog (Split Program) parameter. The Prog parameter determines the Program for the left-hand side of the Split, also known as the “Split Program”. Initially the last used Split Program will be selected, or the default Split Program (210 Motown Bass) if this is the first time using the Split Function since power-up. Choose a Split Program using the Category and Program/Multi buttons, the Alpha Wheel, or the Previous/Next buttons.

Vol (Split Volume)

Press the VOLUME soft button to change the Vol (Split Volume) parameter. This parameter determines the volumes of the left and right-hand Programs. By default, the Split Volume is set to 0, which results in both Programs having the same volume. When set to a positive number, the volume for the right hand Program is decreased. When set to a negative number, the volume for the left hand Program is decreased. To set the Split Volume, use the Alpha Wheel, Previous/Next buttons, or enter a number using the numbers printed on the Program/Multi buttons followed by pressing the Enter button. Split Volume can be set to any number between -127 and 127. Pressing the Value Jump button pair (Previous & Next) resets the volume to 0.

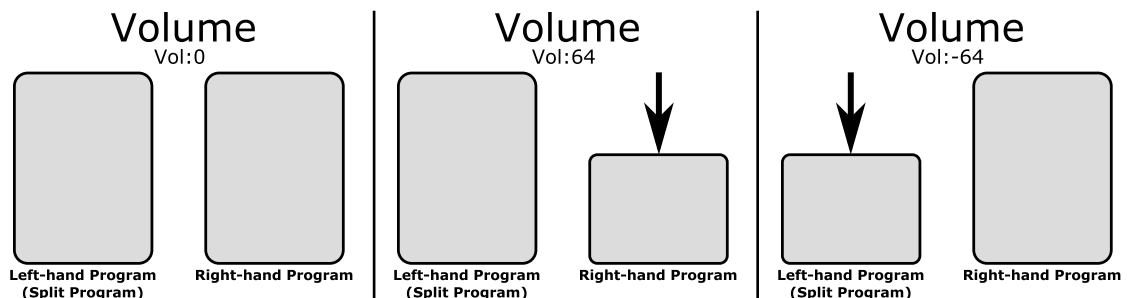

Program Mode

The Split Function

Key (Split Key)

Press the KEY soft button to change the Key (Split Key) parameter. This parameter sets the keyboard key that will be the boundary between the left and right hand Programs on the keyboard. The selected key will be the highest note for the left-hand Split Program. All keys higher than the Split Key will play the right-hand Program. By default, the Split Key is set to B3. The Split Key can be selected using Assign , by holding down the Enter button and then striking the desired key on the keyboard. The Split Key can also be selected by using the Alpha Wheel, Previous/Next buttons, or by entering a number using the numbers printed on the Program/Multi buttons. Split Key can be set to any key between A0 and C8.

Transpose (Split Transposition)

Press the XPOSE soft button to change the Transpose (Split Transposition) parameter. This parameter allows you to transpose the left-hand Split Program in octaves so that you can play it in higher or lower octaves. Use the Alpha Wheel or Previous/Next buttons to set the Transpose value. Transpose can be set to -24, -12, 0, 12, and 24. By default, Split Transposition is set to +12.

Saving a Split

After setting the Split parameters, the Split can be saved as a Multi so that it can easily be recalled in Multi Mode. Press the Save button to the left of the display to begin the saving process.

See Save & Delete User Multis (page 7-12) in the Multi Mode Chapter for details on saving. Once you have saved your Split as a Multi, you can continue to add Split or Layer Zones to the Multi until you reach the maximum of four active Zones.

See the Split Function (page 7-8) and The Layer Function (page 7-10) in the Multi Mode Chapter. Also, once you have saved your Split as a Multi, you can edit controller assignments and other Multi parameters in Multi Edit Mode (see Multi Edit Mode on page 8-1 for details)

The Layer Function

Pressing the Layer soft button while in Program Mode will perform the Layer Function. The Layer Function allows you to layer Programs and Multis such that more than one sound can be produced by striking one key.

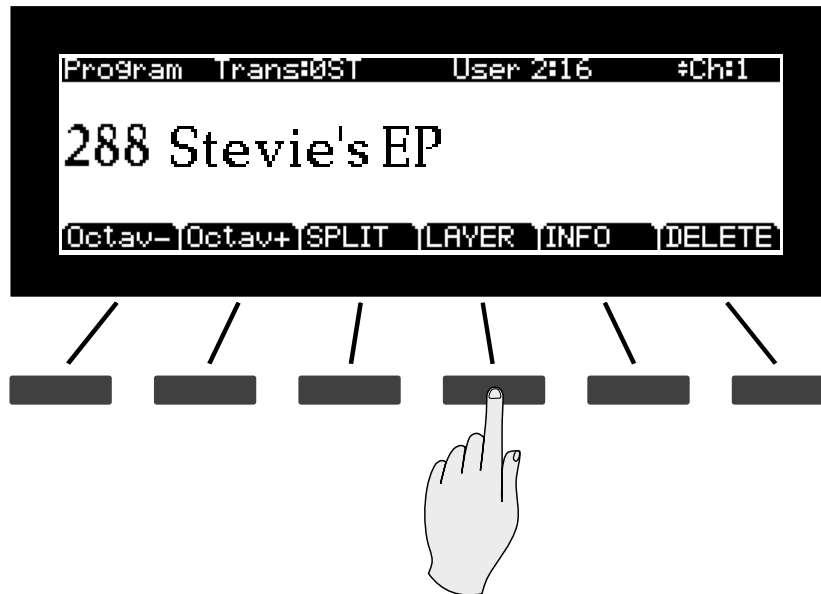

When you create a Layer in Program Mode, you are in fact creating a Multi with two active Zones (see Multi Mode on page 7-1, for more information on Multis). As previously described, Multis are configurations of four Zones, each of which may have its own Program and controller assignments.

The Layer Function is convenient, as you do not need to use Multi Edit Mode to configure Zone key ranges, Programs, and volumes. You can simply hit the Layer button, and the Artis automatically creates a Multi with two active Zones. The Program you were using in Program Mode is used as the Program for Zone 1. After this you can choose a "Layer Program" that will be used as the Program for Zone 2.

Once you have saved your Layer as a Multi, you can continue to add Layer or Split Zones in Multi Mode until you reach the maximum of four active Zones. The Artis will display a message when you have reached the maximum of four active Zones (see Multi Mode on page 7-1, for more information on Multis)

Program Mode

The Layer Function

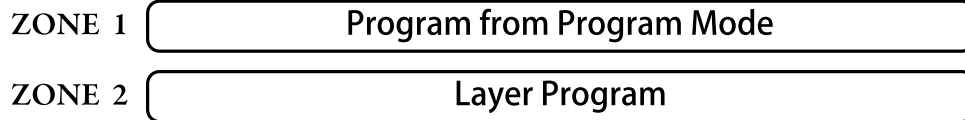

There are three parameters (described below) that determine the behavior of the Layer. Press one of the three soft buttons on the bottom left of the display to access each of the Layer parameters.

Prog (Layer Program)

Press the PROG soft button to change the Prog (Layer Program) parameter. The Prog parameter determines the “Layer Program” that will be layered on top of the Program you were using in Program Mode. Initially the last used Layer Program will be selected, or the default Layer Program (192 Add a Pad 2) if this is the first time using the Layer Function since power-up. Choose a Layer Program using the Category and Program/Multi buttons, the Alpha Wheel, or the Previous/Next buttons.

Vol (Layer Volume)

Press the VOLUME soft button to change the Vol (Layer Volume) parameter. This parameter determines the volumes of the Program from Program Mode and the Layer Program. By default, the Layer Volume is set to 0, which results in both Programs having the same volume. When set to a positive number, the volume for the Program from Program Mode is decreased. When set to a negative number, the volume for the Layer Program is decreased. To set the Layer Volume, use the Alpha Wheel, Previous/Next buttons, or enter a number using the numbers printed on the Program/Multi buttons followed by pressing the Enter button. Layer Volume can be set to any number between -127 and 127. Pressing the Value Jump button pair (Previous & Next) resets the volume to 0.

Transpose (Layer Transposition)

Press the XPOSE soft button to change the Transpose (Layer Transposition) parameter. This parameter allows you to transpose the Layer Program in octaves so that it sounds octaves higher or lower than the other Program you are layering on top of. Use the Alpha Wheel or Previous/Next buttons to set the Transpose value. Transpose can be set to -24, -12, 0, 12, and 24. By default, Layer Transposition is set to 0.

Saving a Layer

After setting the Layer parameters, the Layer can be saved as a Multi so that it can easily be recalled in Multi Mode. Press the Save button to the left of the display to begin the saving process. See Save & Delete User Multis (page 7-12) in the Multi Mode Chapter for details on saving.

Once you have saved your Layer as a Multi, you can continue to add Split or Layer Zones to the Multi until you reach the maximum of four active Zones. See the Split Function (page 7-8) and The Layer Function (page 7-10) in the Multi Mode Chapter. Also, once you have saved your Layer as a Multi, you can edit controller assignments and other Multi parameters in Multi Edit Mode (see Multi Edit Mode on page 8-1 for details).

Program Mode

Changing the Transmit MIDI Channel

Changing the Transmit MIDI Channel

The current MIDI Transmit channel is shown on the right side of the top line of the display. Press the Param/Channel Up or Down buttons to change the MIDI Transmit channel.



Pressing both Param/ Channel Up and Down at the same time will reset the current MIDI Transmit channel to 1.

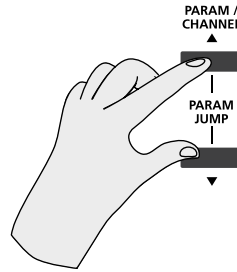

If a MIDI Channel is disabled, the Program name is shown with parenthesis and the message "Channel disabled" on the line above.



MIDI Channels are enabled/disabled in Global Mode, see Channel Enable (ChanEn) on page 9-10.

Panic

Pressing the 15 and 16 Program/Multi buttons simultaneously deactivates all sounding notes and resets controller values by sending an “All Notes Off” message and a “Reset All Controllers” message on all 16 MIDI channels.

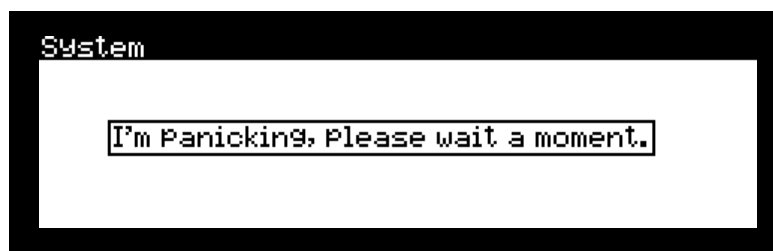
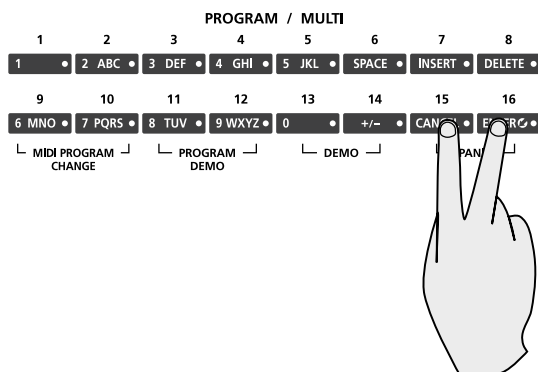

Program Mode

Save & Delete User Programs

Save & Delete User Programs

If you make changes to the current Program using any of the controllers, the Save button's LED lights to indicate that a change has been made to that Program.

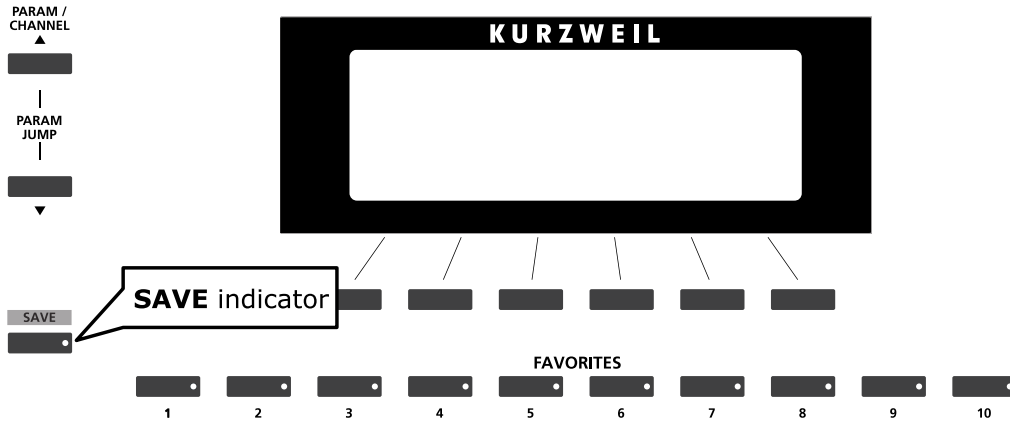

To save the changes you've made, press the Save button once. The Save button's LED begins to blink and it calls up the Save Dialog.

The display shows the first available ID number and the current Program name. You can save Programs with ID numbers from 257 to 512. When you initially press the Save button, the Artis always selects the next available unused ID number and displays the current Program name.

In the Save Dialog, there are two parameters available which allow you to specify the ID number and rename the Program. Use the first parameter to change the ID number and the second to rename the Program.

Changing ID Numbers

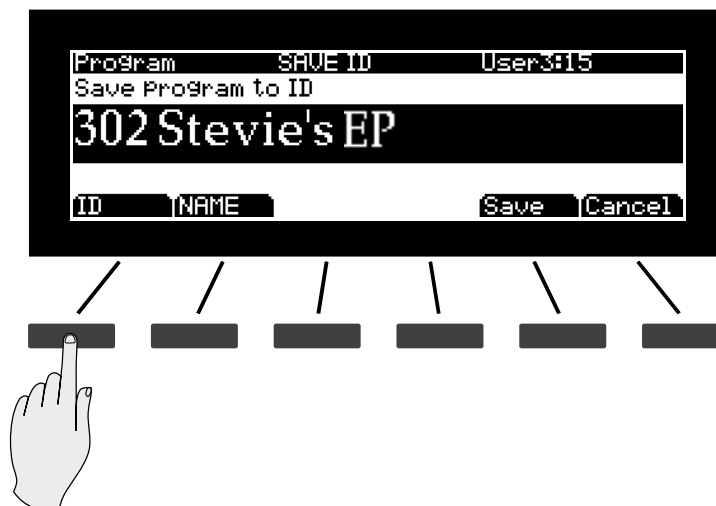

To change the ID number press the ID soft button, turn the Alpha Wheel or use the Value buttons to select the new ID number. You can also use the Category and Program/Multi buttons to select an ID number, which is useful for organizing user Programs by Category. To do this, first select a Category button, then select a Program/Multi button to select an ID within that category.

Naming a User Program

To rename the Program, first press the Name soft button. You should see the following in the display:

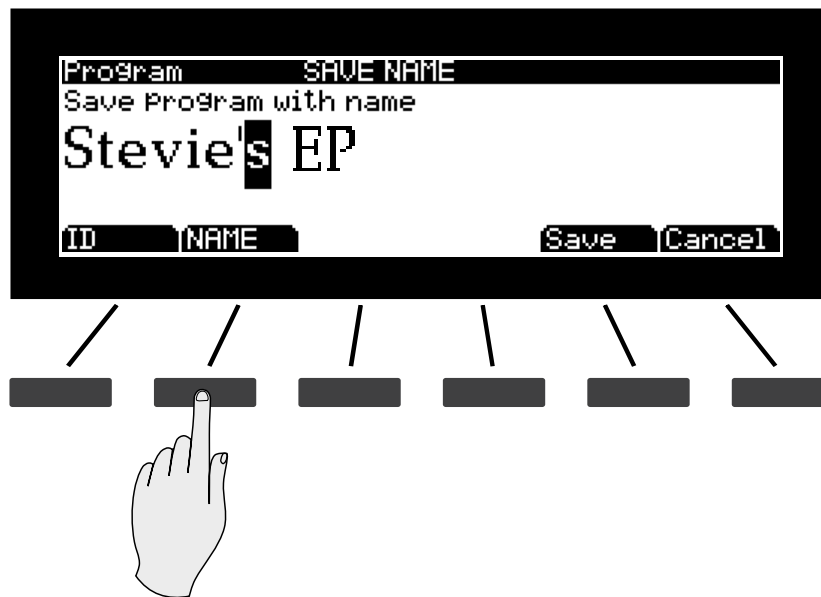

The display shows the current Program name. Program names can total 16 characters in length. Use the letters and numbers printed on the Program/Multi buttons to enter the new Program name.

Press the Previous or Next button to move the cursor. Press the +/- button to switch between upper and lower case characters (all characters will be upper case until you press the +/- button again).

Use the Space button to change the current character to a space, the Insert button to insert a blank space (the selected character and all characters to the right will move one space to the right), and the Delete button to delete the current character (all the characters to the right will move one space to the left).

Program Mode

Save & Delete User Programs

Saving a User Program

Press the Save button or Save soft button to complete the saving process, or press the Cancel soft button to exit without saving. After successfully saving, the Program will be selected in Program Mode in the User Bank. To find the Program again later, make sure to press the User bank button under the Mode buttons.

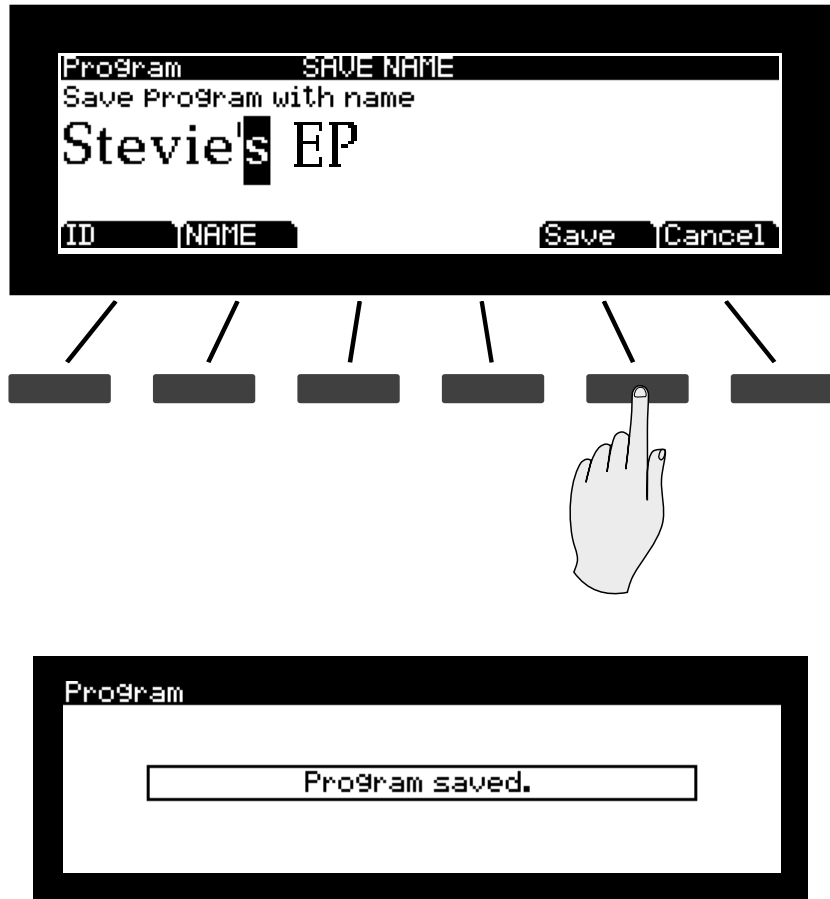

Deleting User Programs

To delete a User Program, select the Program and press the DELETE soft button.

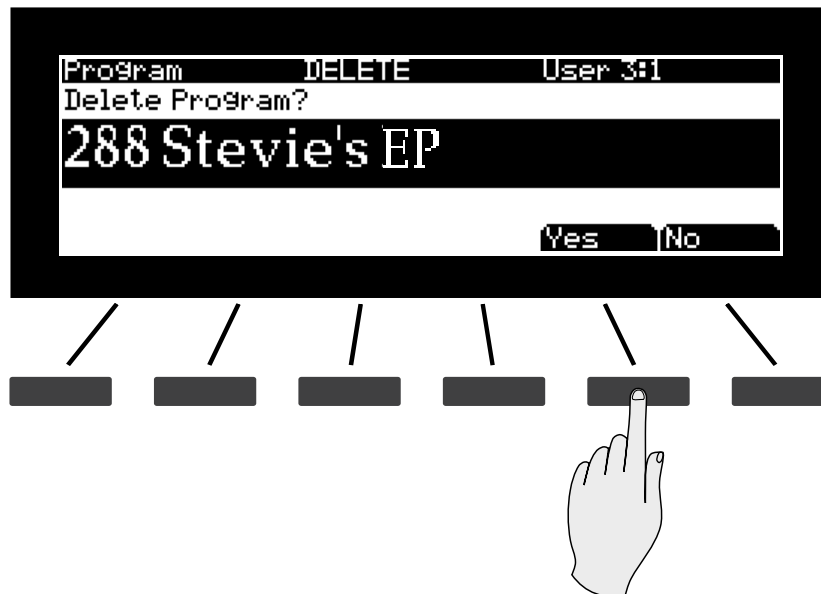
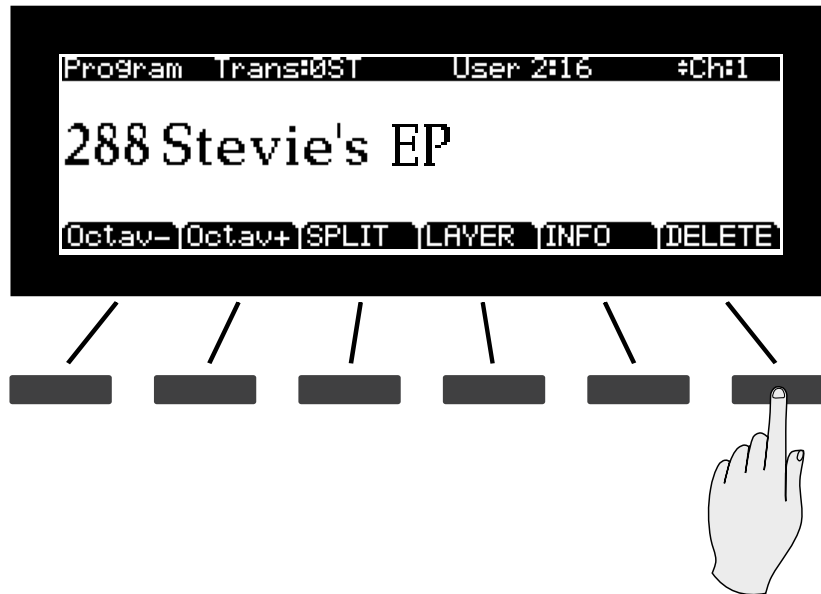

Press the **Yes** button to delete the Program, or **No** to cancel and exit.



Program Mode

INFO

INFO

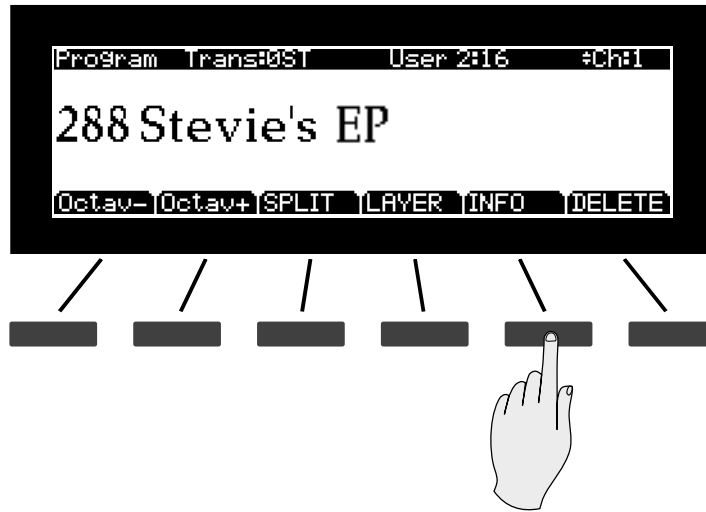

Press the INFO soft button to select the Program Info page.

The Program Info page shows a list of parameter assignments for the currently selected Program. This is a list of Program and effects parameters that are assigned to be controlled by the physical controllers of the Artis (Sliders, Pedals, Switches, Mod Wheel, etc.), or by MIDI continuous controller messages sent from external MIDI equipment. Use the Param/Channel buttons to the left of the display to scroll through the list. Press the Back soft button to return to the Program Mode main page.

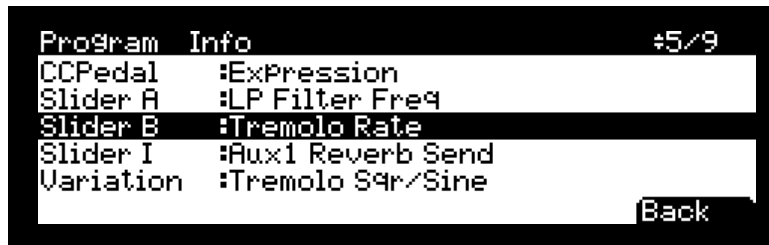

Chapter 7

Multi Mode

This chapter will help familiarize you with the features of Multi Mode.

Multis are configurations of four Zones (explained below in About Zones), each of which may have its own Program, controller assignments, and MIDI transmit channel. A Zone can also be configured to control an external sound module or computer software through a MIDI or USB cable.

About Multi Mode

To enter Multi Mode from another Mode, press the Multi Mode button.

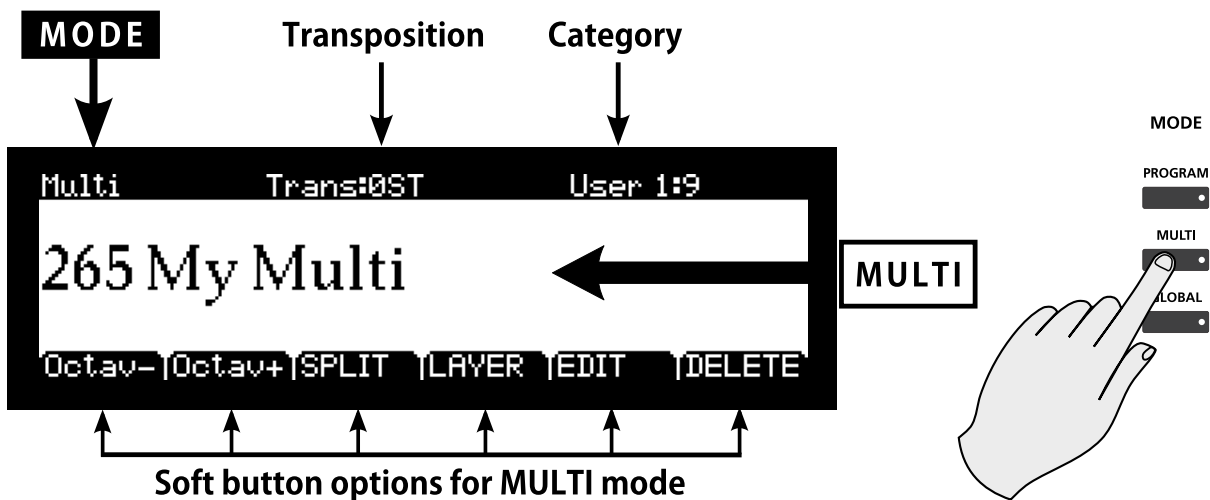

While you are in Multi Mode, the Multi button's indicator LED is illuminated.

When you enter Multi Mode after powering on the Artis, the Category Default Multi in the Piano1 Category will be selected, either Multi 1 (factory default) or a Multi you pick as a Category Default Multi, see Choosing Category Default Multis on page 7-4.

Selecting Multis

When you are in Multi Mode, there are a few ways to select Multis.

- To select any Multi in the current Category, press a Program/Multi Button.
- To select a Multi in a different Category, press the Category Button of choice and then the Program/Multi Button to select from the 16 Multis in the Category.
- To select the Category Default Multi, simply press a Category Button.
- To switch between the Factory and User Multis, press the User Button, followed by a Category button and then a Program/Multi button.
- The Alpha Wheel and the Next and Previous buttons allow you to advance through the Multis one at a time. When you reach the end of the Category, advancing further will go to the next Category.
- If a Multi is assigned to a Favorite Button, pressing that button will go directly to the assigned Multi.

The Display

In Multi Mode, the top line of the display shows the current Mode, MIDI transposition and category. The body of the display shows the Multi ID number and name.

Factory Multi Categories on the top line correspond with the labels above of the Category Buttons. For User Multis, the Categories are labelled User 1, User 2 ... User 16.

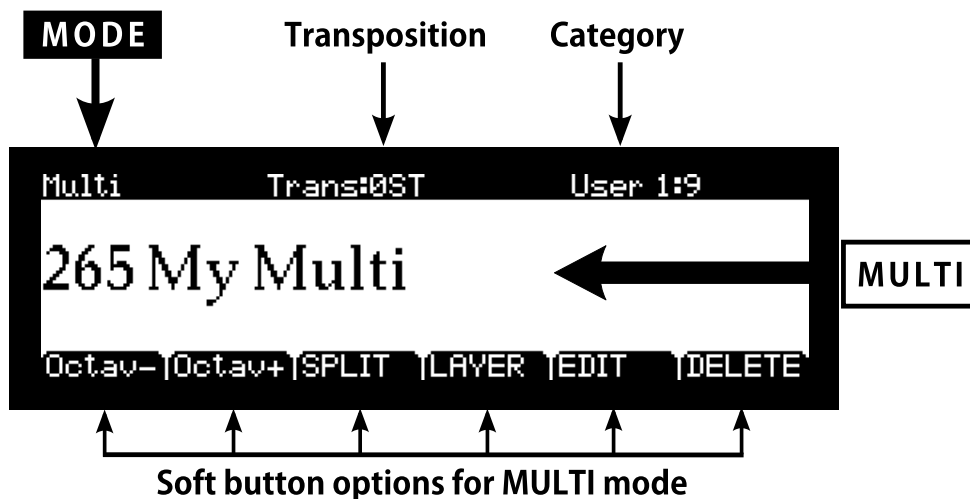

Pop Up Messages

Some actions cause the display to show pop up messages. After a short time the display returns to show the current Multi.

Alpha Wheel & Previous (-) and Next (+) Value Buttons

Use the Alpha Wheel or the Value buttons, to the right of the display below the Alpha Wheel, to change the current Multi. Turning the Alpha Wheel counter-clockwise or pressing the Previous button will select the previous Multi and turning the Alpha Wheel clockwise or pressing the Next button will select the next Multi. When the highest or lowest Multi is reached, the list will wrap back to the last or first Multi respectively.

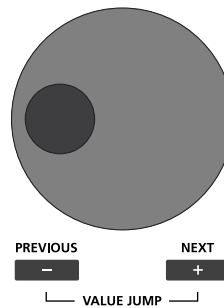

Value Jump Buttons

In Multi Mode, the Value Jump double button press selects the first Multi of each Category, as well as the Category Default Multi of each Category (if a Category Default Multi has been set). For more information on choosing a new Category Default Multi, see Choosing Category Default Multis on page 7-4. If the User button is selected, Value Jump works the same way.

Multi Mode

Selecting Multis

Category & Program/Multi Buttons

The Category buttons allow you to select Multis by instrument type simply by pressing a button. You can select one Category button at a time and the current Category button's LED is lit.

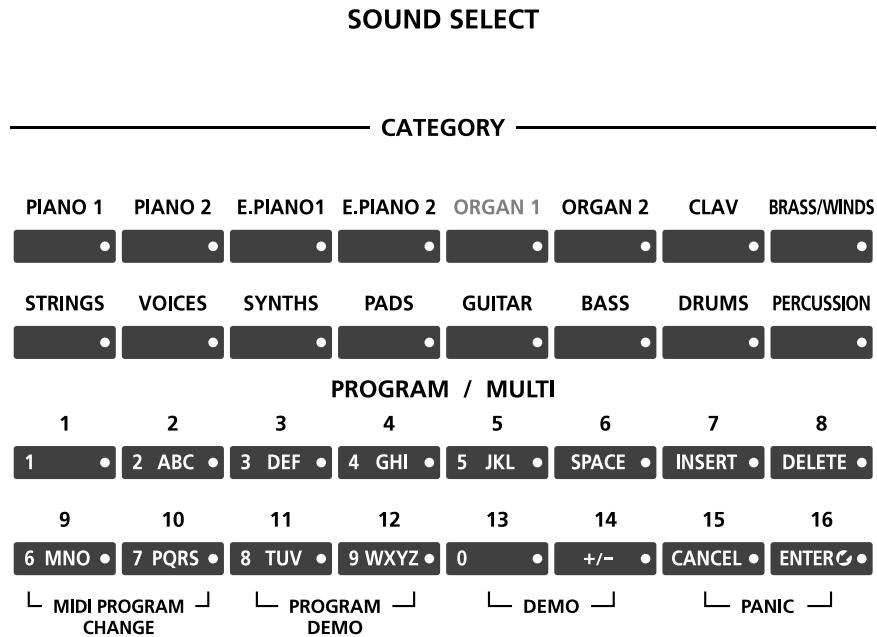

Each Category contains 16 Multis. First select the Category you want, then select one of the 16 Multis by pressing any of the Program/Multi buttons numbered from 1 to 16.

Choosing Category Default Multis

You can choose a “Category Default Multi” from each Category that will be recalled each time you press that Category’s button. To save a Category Default Multi, first select a Multi using any Multi select method (Alpha wheel, Previous/Next buttons, Category buttons, Program/Multi buttons). A Category button for the current Category will have a lit LED. Next, press and hold the currently lit Category button until the display shows the message “Category default multi saved.” The Category default Multi has now been successfully saved.

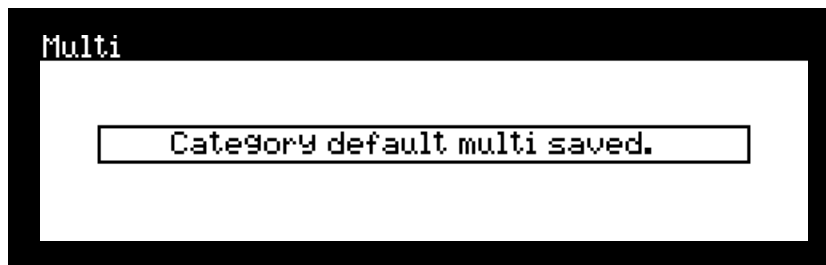

You can save one Category Default Multi per Category button.

Choosing Favorites

You can save ten Favorite Multis (or Programs) from any Category to the ten Favorite Buttons beneath the display. Once saved, these Favorite Multis can be recalled from any Mode with a single button press. To save the currently selected Multi to a Favorite Button, press and hold a Favorite Button until the display shows the message “Multi saved to favorite button.”

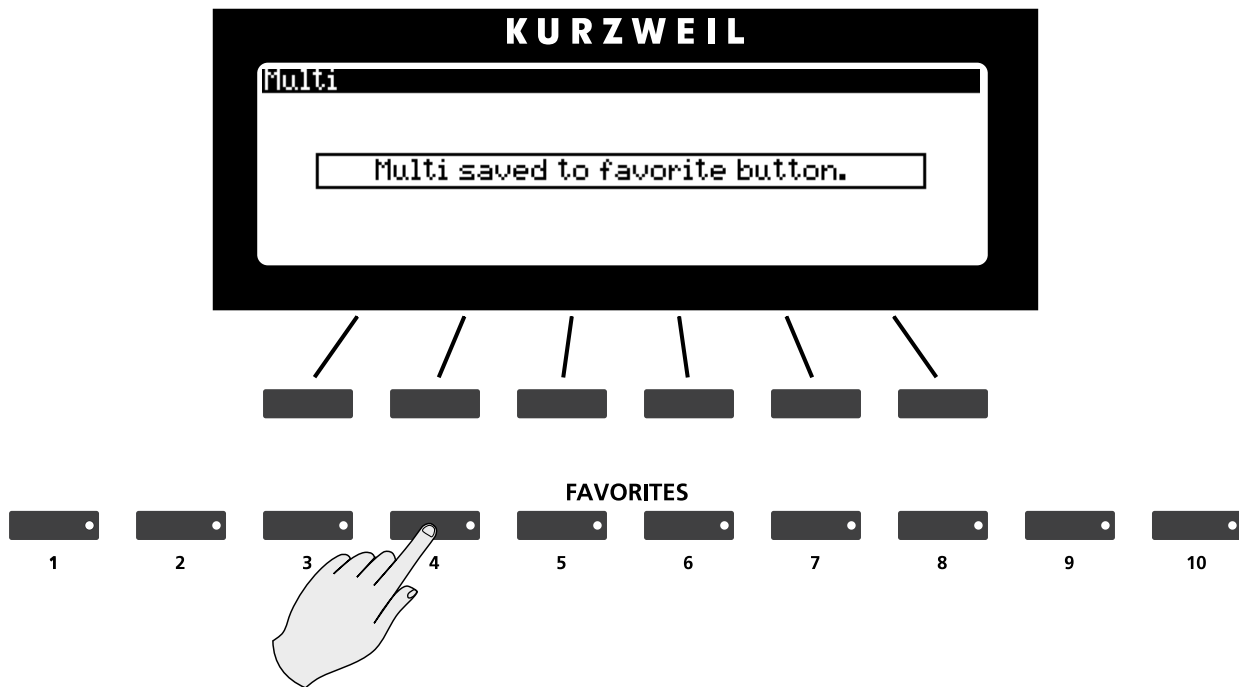

About Zones

Zones are the independent regions of the keyboard that make up a Multi.

A Multi has four Zones, each one having its own Program, controller assignments, and MIDI transmit channel. Zones can be mutually exclusive regions of the keyboard, or they can overlap. A Zone can also be configured to control an external sound module or computer software through a MIDI or USB cable.

Muting Zones

Pressing a Zone button will mute or unmute the Zone. An active/unmuted Zone button has a lit LED. The LED of an inactive/muted Zone button is not lit.

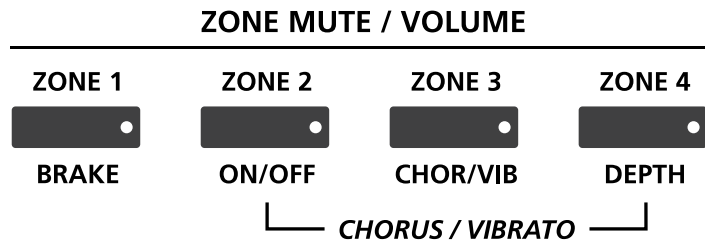

Transposition

The Transpose buttons can be used to change the tuning of notes played on the Artis keyboard in semitones (ST), also known as half steps. This is a convenient way to change the key of a song without learning to play it in a different key. The Transpose buttons are located to the left of the keyboard, above the Pitch and Mod Wheels. The Transpose buttons also transpose MIDI notes sent to the USB and MIDI out ports.

Press the Transpose - or + buttons to transpose the Artis keyboard down or up by one semitone. The top line of the display shows the current transposition value. Pressing both Transpose - and + simultaneously will reset the transposition to 0. To transpose up and down by octave intervals (12 ST), press the Octav- and Octav+ soft buttons underneath the display.

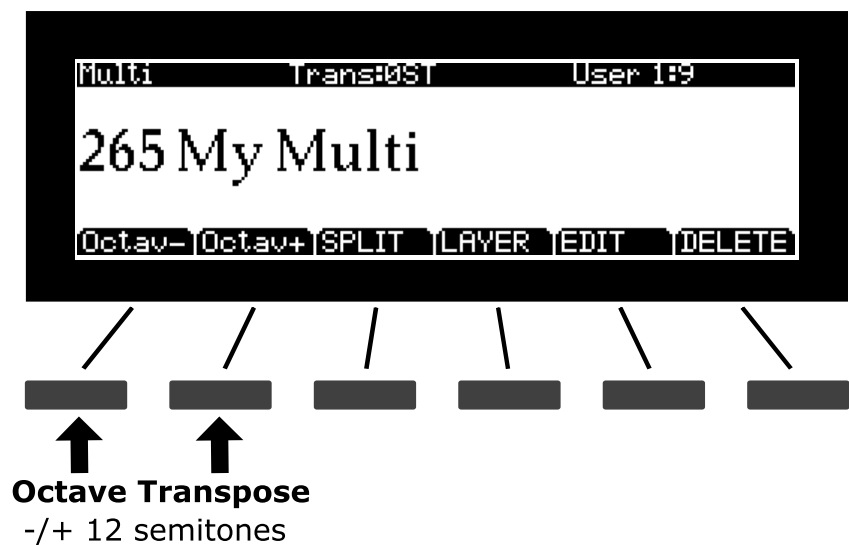
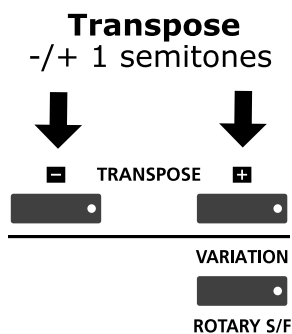

The maximum transposition value possible is +/-36 semitones.

The LEDs of the Transpose buttons indicate whether the current Multi is transposed up (Transpose + LED is lit) or transposed down (Transpose - LED is lit). When there is no transposition, neither Transpose button is lit.



NOTE : That the transposition is applied to all Programs in the Zones within the Multi. The Zone layout on the keyboard however still remains fixed.

The Split Function

Pressing the Split soft button while in Multi Mode performs the Split Function. The Split Function allows you to split Multis such that keys in one region of the keyboard produce different sounds than another region.

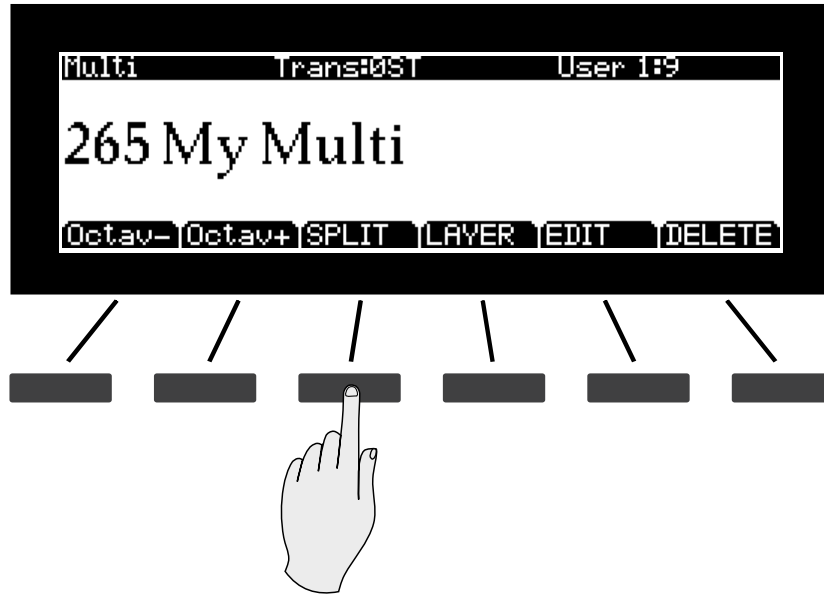

When you create a Split in a Multi, you are in fact activating a new Zone within the current Multi. If the current Multi already has its maximum of four active Zones and you press the Split Function soft button, then a message will appear on the display indicating that you have reached the maximum of four active Zones. Once you have saved your Split, you can continue to add Split or Layer Zones to the Multi until you reach the maximum of four active Zones.

The Split Function is convenient, as you do not need to use Multi Edit Mode to configure Zone key ranges, Programs, and volumes. You can simply press the Split button, and the Artis automatically activates another Zone in the Multi for you. The previously active Zones are used in the right hand of the Split. After this you can choose a “Split Program” that will be used in the left hand of the Split as the Program for the newly activated Zone.

There are four parameters (described below) that determine the behavior of the Split. Press one of the four soft buttons on the bottom left of the display to access each of the Split parameters.

Prog (Split Program)

Press the PROG soft button to change the Prog (Split Program) parameter. The Prog parameter determines the Program for the left-hand side of the Split, also known as the “Split Program”.

Initially the last used Split Program will be selected, or the default Split Program (210 Motown Bass) if this is the first time using the Split Function since power-up. Choose a Split Program using the Category and Program/Multi buttons, the Alpha Wheel, or the Previous/Next buttons.

Vol (Split Volume)

Press the VOLUME soft button to change the Vol (Split Volume) parameter. This parameter determines the volumes of the left and right-hand Zones. By default, the Split Volume is set to 0, which results in all Zones having the same volume. When set to a positive number, the volume for the right hand Zone(s) is decreased. When set to a negative number, the volume for the left hand Zone(s) is decreased. To set the Split Volume, use the Alpha Wheel, Previous/Next buttons, or enter a number using the numbers printed on the Program/Multi buttons followed by pressing the Enter button. Split Volume can be set to any number between -127 and 127.

Pressing the Value Jump button pair (Previous & Next) resets the volume to 0.

Key (Split Key)

Press the KEY soft button to change the Key (Split Key) parameter. This parameter sets the keyboard key that will be the boundary between the left and right hand Zones on the keyboard. The selected key will be the highest note for the left-hand Split Program. All keys higher than the Split Key will play the right-hand Zone(s). By default, the Split Key is set to B3. The Split Key can be selected using Assign , by holding down the Enter button and then striking the desired key on the keyboard. The Split Key can also be selected by using the Alpha Wheel, Previous/Next buttons, or by entering a number using the numbers printed on the Program/Multi buttons. Split Key can be set to any key between A0 and C8.

Transpose (Split Transposition)

Press the XPOSE soft button to change the Transpose (Split Transposition) parameter. This parameter allows you to transpose the left-hand Split Program in octaves so that you can play it in higher or lower octaves. Use the Alpha Wheel or Previous/Next buttons to set the Transpose value. Transpose can be set to -24, -12, 0, 12, and 24. By default, Split Transposition is set to +12.

Saving a Split

After setting the Split parameters, press the Save button to the left of the display to begin the saving process. See Save & Delete User Multis (page 7-12) for details on saving. Once you have saved your Split, you can continue to add Split or Layer Zones to the Multi until you reach the maximum of four active Zones. Also, once you have saved your Split, you can edit controller assignments and other Multi parameters in Multi Edit Mode (see Multi Edit Mode on page 8-1 for details).

Multi Mode

The Layer Function

The Layer Function

Pressing the Layer soft button while in Multi Mode performs the Layer Function. The Layer Function allows you to layer Programs and Multis such that more than one sound can be produced by striking one key.

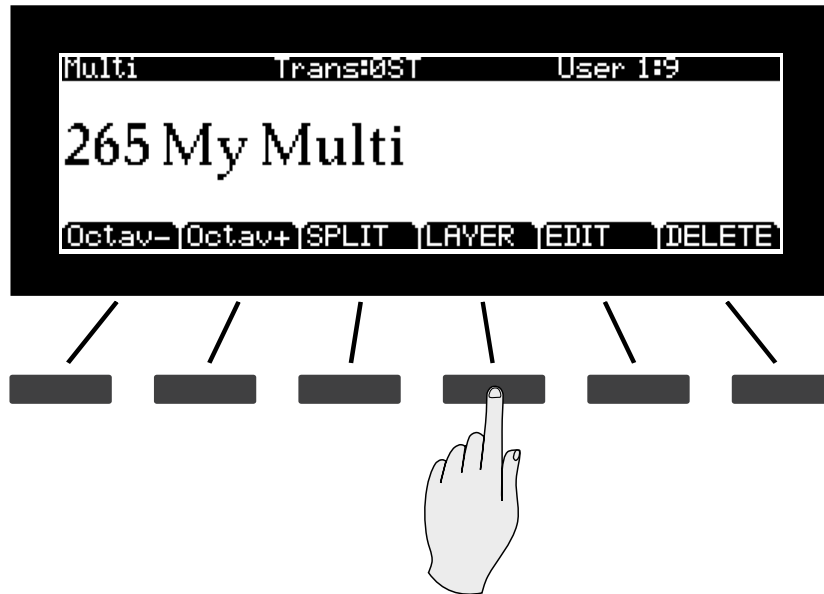

When you create a Layer in a Multi, you are in fact activating a Zone within the current Multi. If the current Multi already has its maximum of four active Zones and you press the Layer Function soft button, then a message will appear on the display indicating that you have reached the maximum of four active Zones. Once you have saved your Layer, you can continue to add Layer or Split Zones to the Multi until you reach the maximum of four active Zones.

The Layer Function is convenient, as you do not need to use Multi Edit Mode to configure Zone key ranges, Programs, and volumes. You can simply press the Layer soft button, and the Artis automatically activates another Zone in the Multi to layer with the previously active Zones. After this you can choose a “Layer Program” that will be used as the Program for newly activated Zone.

There are three parameters (described below) that determine the behavior of the Layer. Press one of the three soft buttons on the bottom left of the display to access each of the Layer parameters.

Prog (Layer Program)

Press the PROG soft button to change the Prog (Layer Program) parameter. The Prog parameter determines the “Layer Program” that will be layered on top of the previously active Zones.

Initially the last used Layer Program will be selected, or the default Layer Program (192 Add a Pad 2) if this is the first time using the Layer Function since power-up. Choose a Layer Program using the Category and Program/Multi buttons, the Alpha Wheel, or the Previous/Next buttons.)

Vol (Layer Volume)

Press the VOLUME soft button to change the Vol (Layer Volume) parameter. This parameter determines the volumes of the Layer Program and the previously active Zone(s). By default, the Layer Volume is set to 0, which results in all Zones having the same volume. When set to a positive number, the volume for the previously active Zone(s) is decreased. When set to a negative number, the volume for the Layer Program is decreased. To set the Layer Volume, use the Alpha Wheel, Previous/Next buttons, or enter a number using the numbers printed on the Program/Multi buttons followed by pressing the Enter button. Layer Volume can be set to any number between -127 and 127.

Pressing the Value Jump button pair (Previous & Next) resets the volume to 0.

Transpose (Layer Transposition)

Press the XPOSE soft button to change the Transpose (Layer Transposition) parameter. This parameter allows you to transpose the Layer Program in octaves so that it sounds octaves higher or lower than the other Zone(s) you are layering on top of. Use the Alpha Wheel or Previous/Next buttons to set the Transpose value. Transpose can be set to -24, -12, 0, 12, and 24. By default, Layer Transposition is set to 0.

Saving a Layer

After setting the Layer parameters, press the Save button to the left of the display to begin the saving process. See Save & Delete User Multis on page 7-12 for details on saving.

Once you have saved your Layer, you can continue to add Split or Layer Zones to the Multi until you reach the maximum of four active Zones. Also, once you have saved your Layer, you can edit controller assignments and other Multi parameters in Multi Edit Mode (see Multi Edit Mode on page 8-1 for details).

Multi Mode

Save & Delete User Multis

Save & Delete User Multis

To save changes to the current User Multi, or to save a changed Factory Multi to a User Category, press the Save button once.

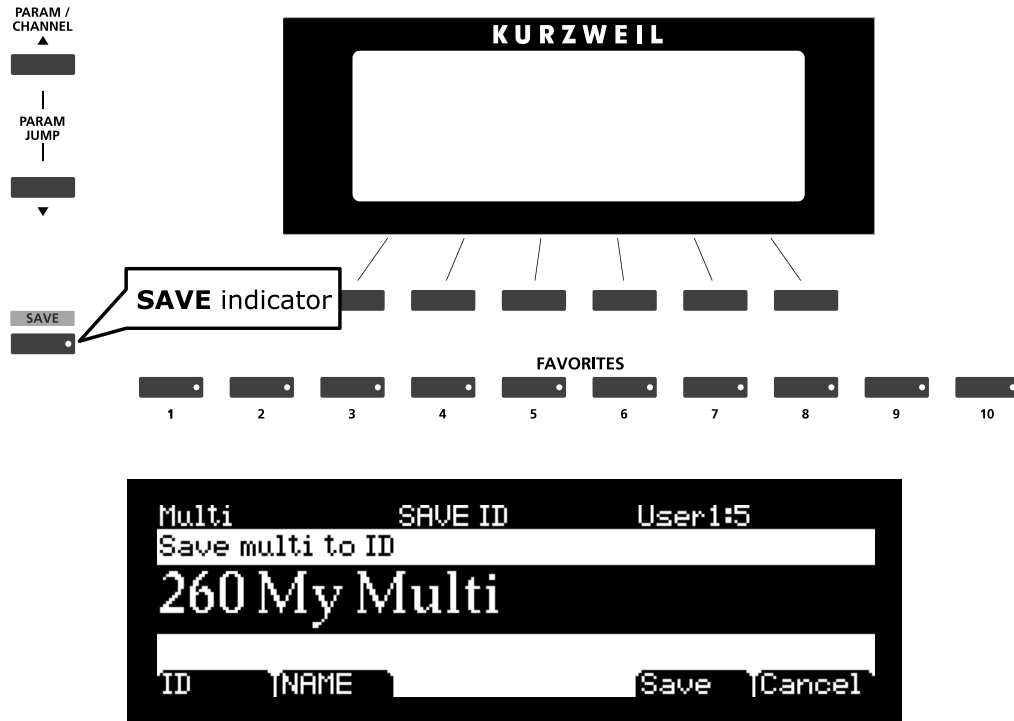

You can save Multis with ID numbers from 257 to 512. When you initially press the Save button, Artis always selects the next available unused ID number and displays the current Multi name.

In the Save Dialog, there are two parameters available which allow you to specify the ID number and rename the Multi. Use the first parameter to change the ID number and the second to rename the Multi.

Changing ID Numbers

To change the ID number press the ID soft button, turn the Alpha Wheel or use the Value buttons to select the new ID number. You can also use the Category and Program/Multi buttons to select an ID number, which is useful for organizing user Multis by Category. To do this, first select a Category button, then select a Program/Multi button to select an ID within that category.

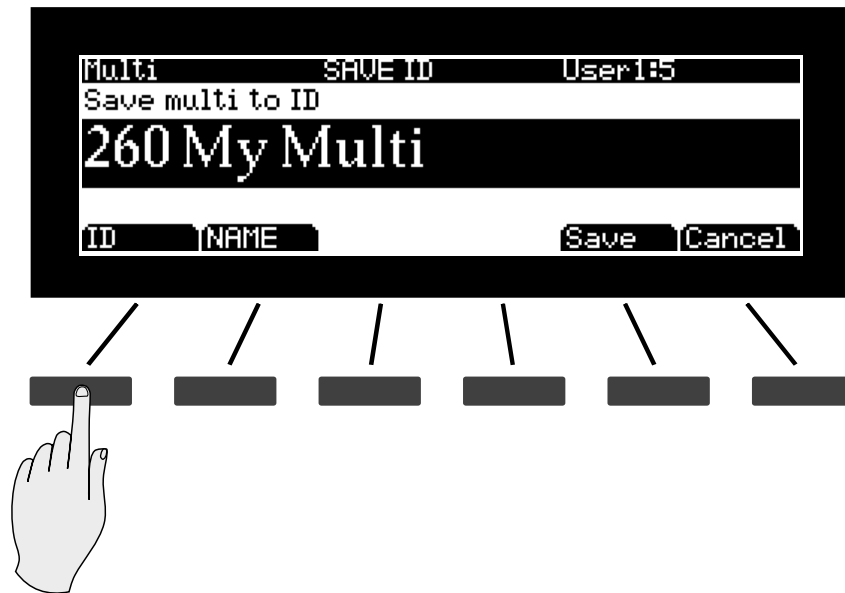

If you choose an ID that is already in use, you will see a warning message.



Confirm overwriting of the existing Multi, by pressing Save, or choose a different ID.

Multi Mode

Save & Delete User Multis

Naming a User Multi

To rename the Multi, first press the NAME soft button. You will see the naming screen in the display.

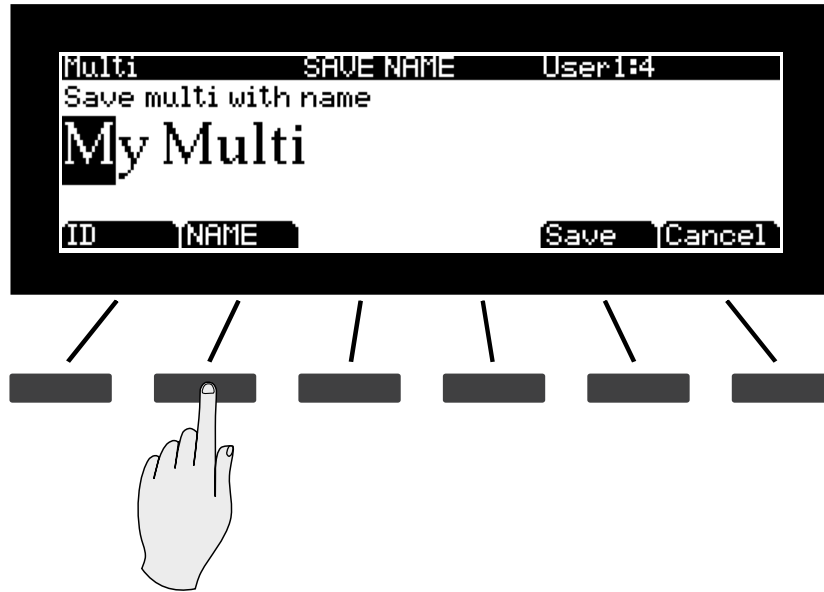

The display shows the current Multi name. Multi names can total 16 characters in length. Use the letters and numbers printed on the Program/Multi buttons to enter the new Program name.

Press the Previous or Next button to move the cursor. Press the +/- button to switch between upper and lower case characters (all characters will be upper case until you press the +/- button again).

Use the Space button to change the current character to a space, the Insert button to insert a blank space (the selected character and all characters to the right will move one space to the right), and the Delete button to delete the current character (all the characters to the right will move one space to the left).

Saving a User Multi

Press the Save button or Save soft button to complete the saving process, or press the Cancel soft button to exit without saving. After successfully saving, the Multi will be selected in Multi Mode in the User Bank. To find the Multi again later, make sure to press the User bank button under the Mode buttons.

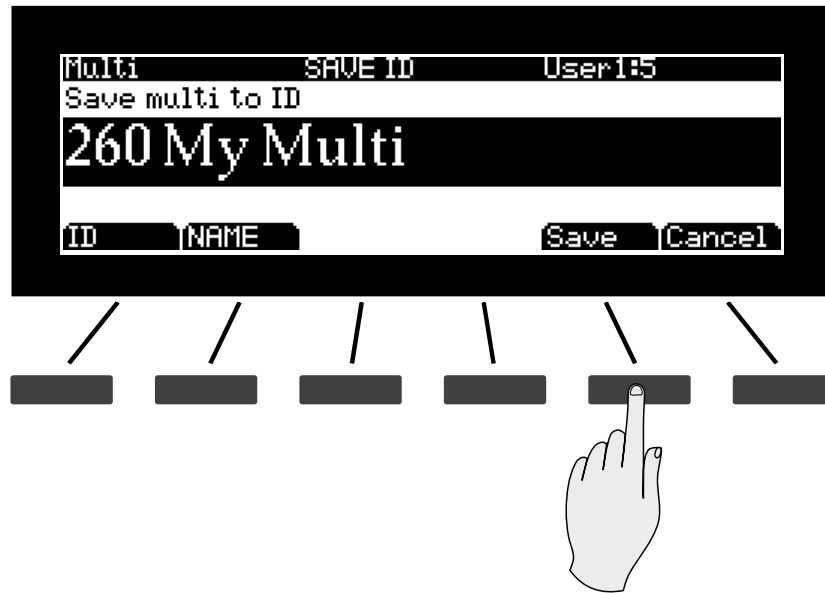

Multi Mode

Save & Delete User Multis

Deleting User Multis

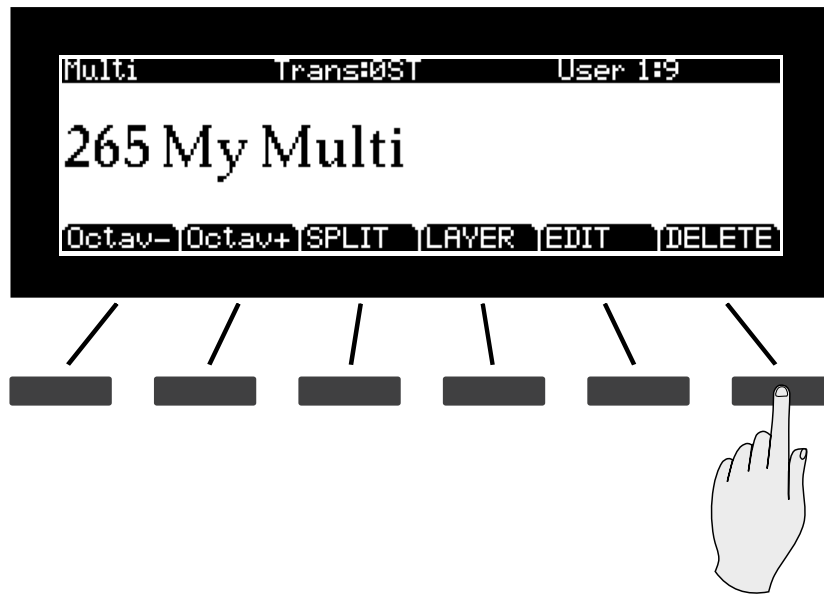

To delete a User Multi, select the Multi and press the DELETE soft button.



Press the Yes soft button to delete the Multi, or No to cancel and exit.

Chapter 8

Multi Edit Mode

This chapter will help familiarize you with the features of Multi Edit Mode.

About Multi Edit Mode



NOTE : Before you read this chapter, be sure to read Multi Mode on page 7-1 for a full description of Multis.

Multi Edit Mode allows you to edit and create Multis and gives you access to a Multi's common parameters and Zone specific parameters. Multis are configurations of four Zones, each of which may have its own Program, controller assignments, and MIDI transmit channel. A Zone can also be configured to control an external sound module or computer software through a MIDI or USB cable.

In Multi Edit Mode, you can customize the Program, controller assignments, and MIDI transmit channel of the Zones in a Multi, in addition to many other parameters. Any Multi can be edited in Multi Edit Mode and saved to one of the 256 User locations.

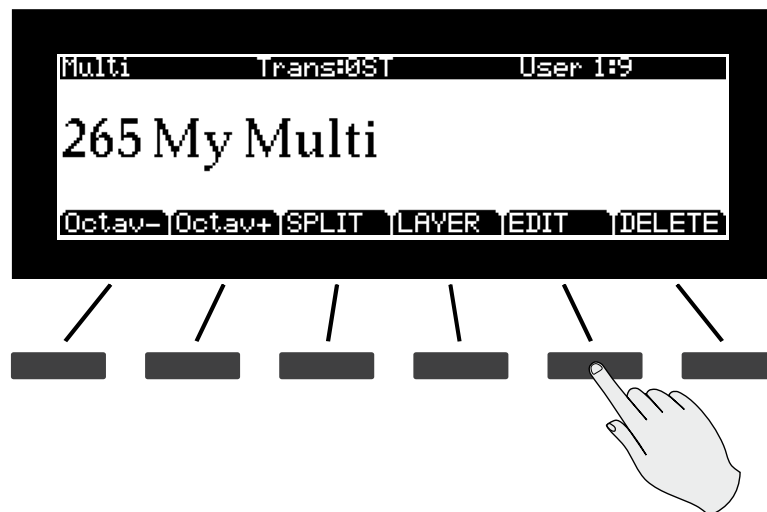

Multi Edit Mode

About Multi Edit Mode

To enter Multi Edit Mode, first press the Multi Mode button to enter Multi Mode, then press the EDIT soft button.

Once you are in Multi Edit Mode, press the soft buttons at the bottom of the screen to navigate to each of the Multi Edit Mode pages. See the sections below for details on navigating and changing parameters and Zones. All parameters apply only to the currently selected Zone, except for parameters on the Common Page, which apply to all Zones..

Selecting Parameters

The Display

In Multi Edit Mode, the top line of the display shows the current Mode, Page, Zone number, and parameter number as well as the total number of available parameters.

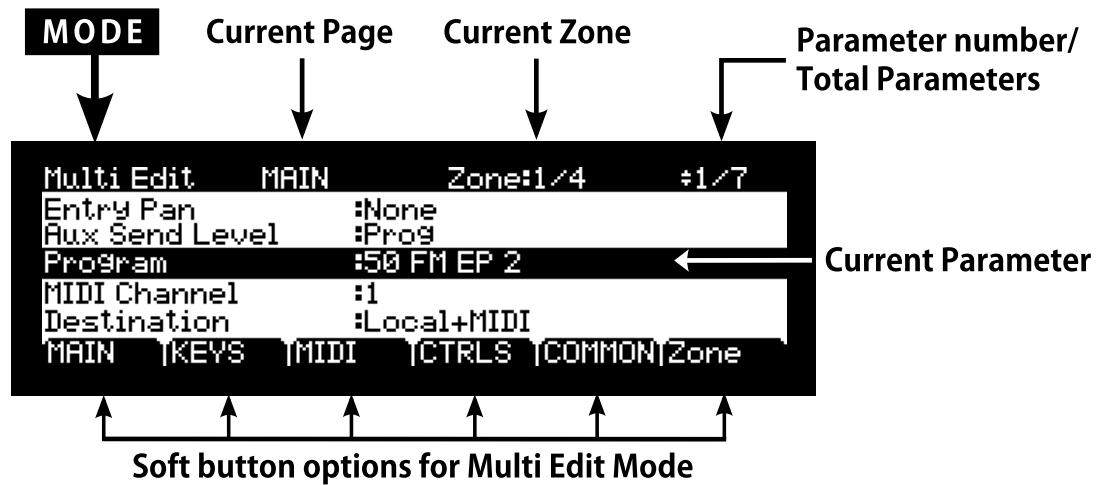

Changing Zones

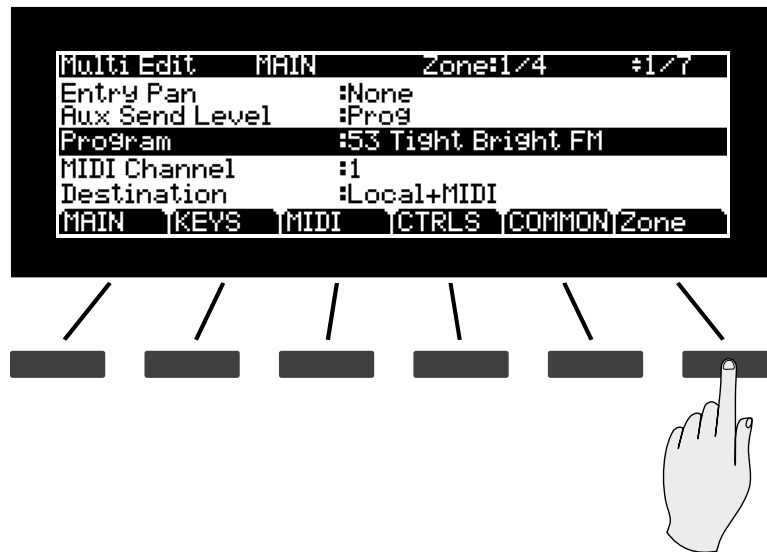

Pressing the Zone soft button changes the currently selected Zone. Press the Zone soft button to cycle through the four available Zones. The top line of the display shows the current Zone number.

A Zone can also be selected using Assign . Hold the Enter button and press a Zone Mute button to select that Zone.

Param / Channel Buttons



Use the Param / Channel buttons to scroll through the list of parameters on each page.

Alpha Wheel & Previous (-) and Next (+) Value Buttons

Use the Alpha Wheel or the Value buttons, to the right of the display below the Alpha Wheel, to change the selected parameter value. Turning the Alpha Wheel counter-clockwise or pressing the Previous button will select the previous value and turning the Alpha Wheel clockwise or pressing the Next button will select the next value.

Value Jump Double Button Press

Pressing the Next and Previous buttons simultaneously resets the parameter to its default value for all parameters.

Param Jump Double Button Press

Pressing the Param / Channel Up and Param / Channel Down buttons simultaneously makes the display “jump” to selecting commonly used parameters. The selected parameter depends on the current page selected (see below).

Page	Jump Parameter
MAIN	Program
KEYS	Transpose
MIDI	MIDI Bank
CTRLS - WHEEL CTRLS - SLIDER CTRLS - PEDAL CTRLS - SWITCH	Param Jump selects the Destination parameter for each physical controller on the page.
COMMON	Aux FX

Assign

Assign is the secondary function of the Enter button.



The Assign symbol will be shown in the display next to parameters that can be selected with Assign.

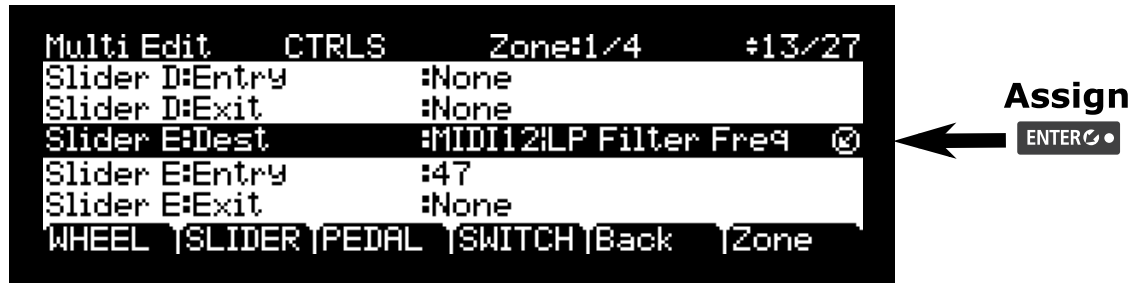

Pressing a key, switch, or moving a controller while holding down the Enter button will perform Assign in the following cases.

Enter + Zone (1–4) Button

In Multi Edit Mode, holding the Enter button and pressing a Multi Zone Mute button will jump to selecting that Zone. The currently selected Zone number can be seen on the top line of the page.

Enter + Controller

In Multi Edit Mode, holding the Enter button and moving a controller (a Slider, Switch button, Mod Wheel or Pedal) will jump to selecting the destination parameter of that controller in the current Zone. This allows you to quickly assign a controller to a destination.

In Multi Edit Mode, holding the Enter button and moving the Pitch Wheel up or down will jump to selecting the Bend Range Up or Bend Range Down parameters of the current Zone.

Enter + Key

In Multi Edit Mode with the Low Key or High Key parameter selected, hold the Enter button and strike a key to set the Low Key or High Key.

Zone Parameters

Each of the four Zones in a Multi has multiple parameters that determine its behavior. Since the Zones of a Multi are independent of each other, changing a parameter for a certain Zone will not affect the parameters of any other Zone.

The Zone parameters for each page are explained in detail below.

MAIN Page

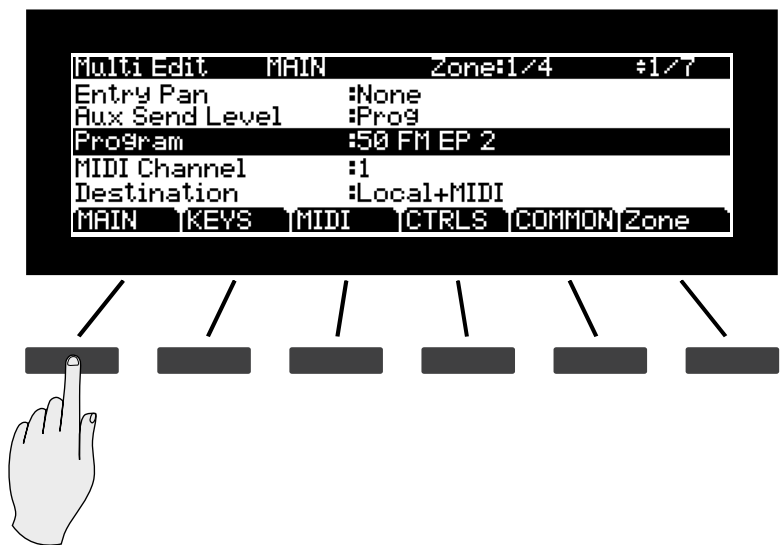

Parameter	Range Of Values	Default Value
Program	Program List	1 Concert Piano
MIDI Channel	1 to 16	1
Destination	Local, MIDI, Local+MIDI	Local+MIDI
Zone Status	Active, Muted	Active
Entry Volume	None, 0 to 127	127
Entry Pan	None, 0 to 127	64
Aux Send Level	0 to 127	10

Program

The Program parameter determines the Program to be loaded for the currently selected Zone. You can set this parameter to any Artis Program (1 – 512). The display shows the Program number and name.

The Value Jump double button press (Previous and Next buttons) jumps to selecting the first Program of each Category, as well as the Category Default Program of each Category (if a Category Default Program has been set).

Editing this parameter also changes the MIDI Bank and MIDI Program parameters, described later.

MIDI Channel

The MIDI Channel parameter determines the MIDI transmit and receive channel for the currently selected Zone. You can set this parameter to any of the 16 MIDI channels (1-16).

Pressing Previous & Next buttons simultaneously will set this parameter to 1.

You can assign different Zones to the same channel, but only one Program can be loaded in a channel at a particular time.

Destination

The Destination parameter determines whether MIDI data generated by the keyboard and physical controllers of the currently selected Zone is sent to an Artis Program, through the MIDI Out/USB ports, or all three. You can set this parameter to any of the three destinations for this parameter:

Note that this parameter works in conjunction with the Global parameter of the same name (see page 9-8) and both are active. They act like filters, so if one is set to MIDI, and the other is set to Local + MIDI, transmission will be limited to MIDI only.



CAUTION: It is possible to stop all MIDI transmission, in Multi Mode, if one Destination parameter is set to Local, and the other is set to MIDI.

1. Local

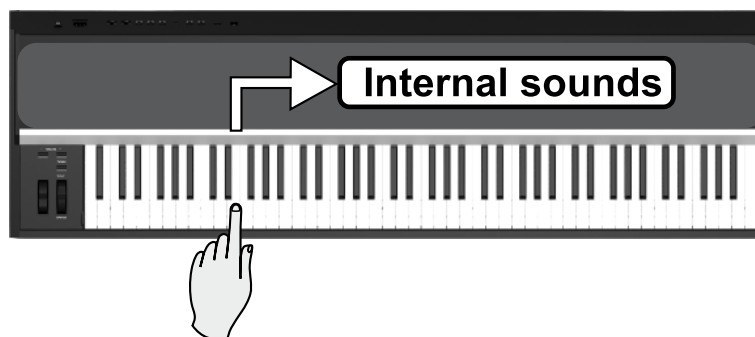

When Destination is set to Local, MIDI data from the Zone is sent only to the Artis Program. MIDI data from this Zone is not sent to the MIDI Out and USB ports.

Multi Edit Mode

Zone Parameters

2. MIDI

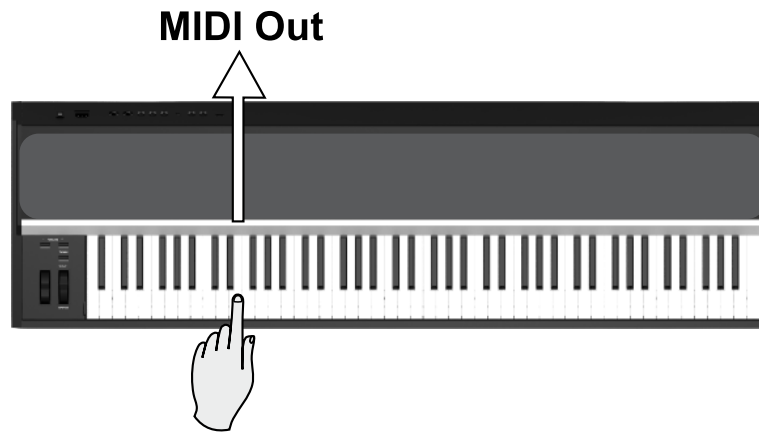

When Destination is set to MIDI, MIDI data from the Zone is sent only to the MIDI Out and USB ports. MIDI data is not sent to an Artis Program on this Zone.

3. Local + MIDI

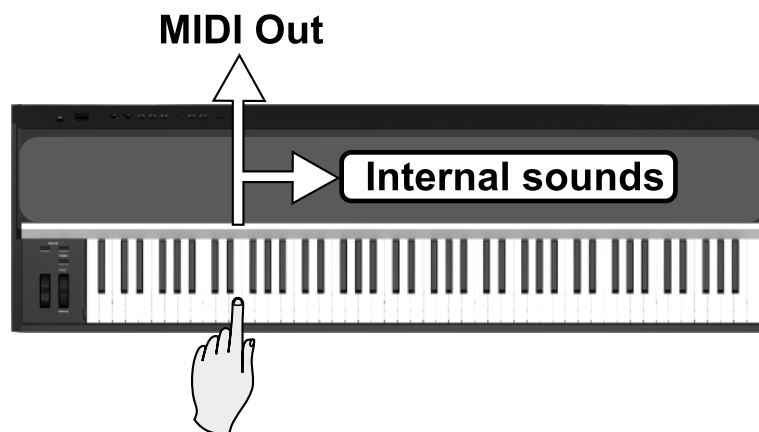

When Destination is set to Local + MIDI, MIDI data from the Zone is sent to an Artis Program and to the MIDI Out and USB ports.



NOTE : MIDI Out applies to the 5-pin MIDI Out and USB ports.

Select the desired destination depending on your needs for that zone.. If you want to play the Artis, but not send any MIDI information to other MIDI instruments, then select Local. If you want to use the Artis strictly as a MIDI controller for the other modules in your MIDI chain, then select MIDI. If you want to make use of the Artis's sounds as well as use it as a MIDI controller, then select Local+MIDI.

Pressing both Previous & Next buttons simultaneously (Value Jump) will set this parameter to Local+MIDI.

Status

The Status parameter determines whether the currently selected Zone is active or muted. You can set this parameter to either of two states: Active or Muted.

Pressing both Previous & Next buttons simultaneously will set this parameter to Active.

Entry Volume

The Entry Volume parameter determines the Volume MIDI message that the currently selected Zone sends when the Multi is loaded. You can set this parameter to any volume setting from None, 0 to 127.

Pressing both Previous & Next buttons simultaneously will set this parameter to 127. None is entered as -1.

Entry Pan

The Entry Pan parameter determines the Pan MIDI message that the currently selected Zone sends when the Multi is loaded. You can set this parameter to any pan setting from None, 0 (full left pan) to 127 (full right pan). To pan to center, select 64 for this parameter.

Pressing both Previous & Next buttons simultaneously will set this parameter to 64. None is entered as -1.

Aux Send Level

The Aux Send Level parameter determines the send level for the auxiliary effects of the currently selected Zone. You can select any level from Prog, 0 to 127.

Pressing both Previous & Next buttons simultaneously will set this parameter to 10. A value of Prog uses the default Aux Send Level that the current Zone's Program uses in Program mode. To enter a value of Prog, use the Alpha Wheel or Previous/Next buttons to scroll lower than 0. A value of Prog can also be selected by using the alphanumeric function of the Program/Multi to enter a value of -1, followed by the Enter button.

For a description of the auxiliary effects of a Multi, see About Auxiliary Effects on page 8-25 and Common Parameters on page 8-23.

KEYS Page

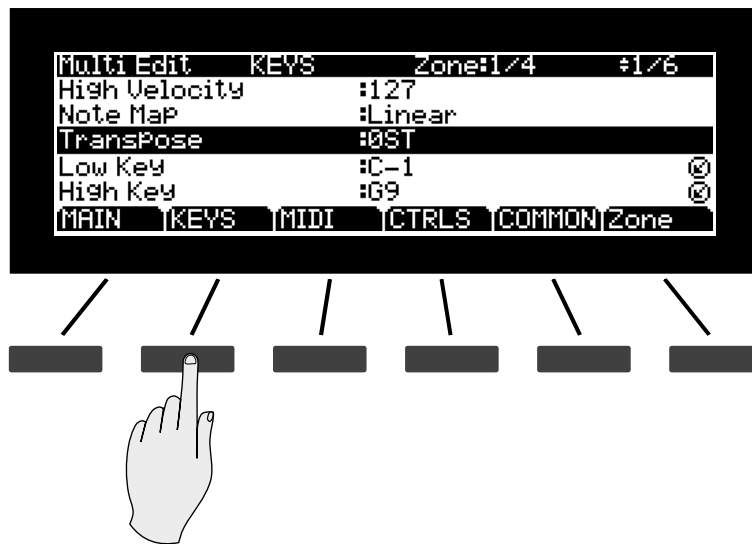

Parameter	Range Of Values	Default Value
Transpose	-128 to 127 ST	0
Low Key	C-1 to G9	C-1
High Key	C-1 to G9	G9
Low Velocity	1 to 127	1
High Velocity	1 to 127	127
Note Map	Off, Linear, Constant	Linear

Transpose

The Transpose parameter determines the transposition for the currently selected Zone. You can set this to any value from -128 semitones to 127 semitones.

Pressing both Previous & Next buttons simultaneously will set this parameter to 0.

Low Key

The Low Key parameter determines the lower boundary of the currently selected Zone. You can set this parameter to any note from C-1 to G9. Pressing both Value buttons simultaneously will set this parameter to C-1.

If, for example, you set Low Key to C4, then only keys at or above C4 will trigger a note for the currently selected Zone. Keys below C4 will not trigger a note.

Pressing both Previous & Next buttons simultaneously will set this parameter to C-1.

High Key

The High Key parameter determines the higher boundary of the currently selected Zone. You can set this parameter to any note from C-1 to G9.

If, for example, you set High Key to C4, then only keys at or below C4 will trigger a note for the currently selected Zone. Keys above C4 will not trigger a note.

Pressing both Previous & Next buttons simultaneously will set this parameter to G9.

Low Velocity

The Low Velocity parameter determines the lowest velocity that a keystroke must have in order to trigger a note in the currently selected Zone. You can set this parameter to any velocity between 1 and 127.

If, for example, you set Low Velocity to 20, then only keystrokes with velocities of 20 or above will trigger a note. Keystrokes with velocities lower than 20 will not trigger a note.

Pressing both Previous & Next buttons simultaneously will set this parameter to 1.

High Velocity

The High Velocity parameter determines the highest velocity that a keystroke must have in order to trigger a note in the currently selected Zone. You can set this parameter to any velocity between 1 and 127. Pressing both Value buttons simultaneously will set this parameter to 127.

If, for example, you set High Velocity to 80, then only keystrokes with velocities of 80 or below will trigger a note. Keystrokes with velocities higher than 80 will not trigger a note.

Pressing both Previous & Next buttons simultaneously will set this parameter to 127.

Note Map

Note Map lets you change the way notes are sent from the Artis.

A setting of Off, no notes are sent but controllers and other non-note data are. If you set Note Map to Constant, all of the keys on the keyboard will play the same note. A Note Map setting of Constant is useful for layering a single drum sound over another Zone, for example layering a ride cymbal over a Zone containing a Bass program. The note defaults to C4, but you can change this with the Transpose parameter.

With Note Map set to Linear, all notes go out as played.

Multi Edit Mode

Zone Parameters

MIDI Page

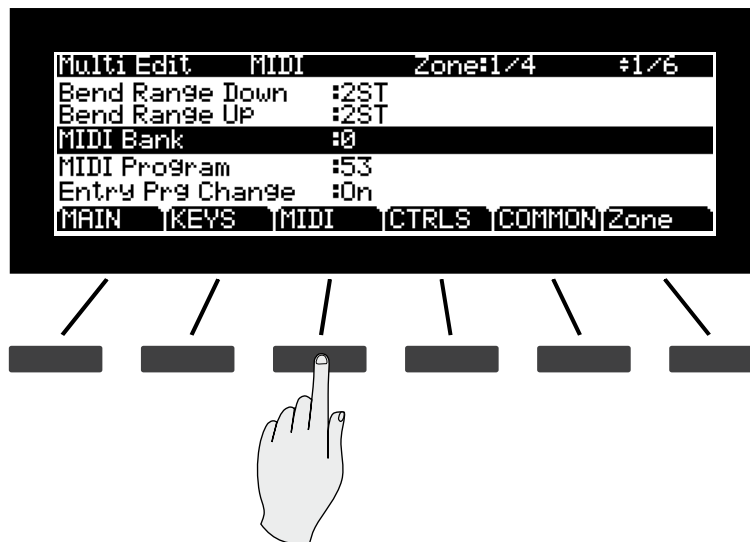

Parameter	Range Of Values	Default Value
MIDI Bank	0 to 127	Bank of LocalProgram
MIDI Program	1 to 128	Program Number of Local Program
Entry Program Change	Off, On	On
Bank Mode	None, Ctl0, Ctl32, Ctl0/32, K2600	Ctl0/32
Bend Range Down	Prog, 0 to 127 ST	12 ST
Bend Range Up	Prog, 0 to 127 ST	2 ST

MIDI Bank

The MIDI Bank parameter determines the MIDI Bank change message that the currently selected Zone sends when the Multi is loaded. You can set this parameter to a MIDI Bank change message from 0 to 127.

When using the Artis as a MIDI controller, sending a MIDI Bank change message (along with a MIDI Program change message) when a Multi is loaded ensures that the Program loaded on the other sound modules in your MIDI chain is the Program that you want.

For example, if you've configured a Multi to work in a specific way with Program 32 in Bank 5 of a connected sound module, then set MIDI Bank to 5 and MIDI Program to 32. This way, whenever you load this Multi, the sound module will automatically load Program 32 in Bank 5. Pressing both Previous & Next buttons simultaneously will set this parameter to the Bank number of the currently selected Local Program.



NOTE : When you change the Program parameter, the MIDI Bank and MIDI Program parameters will automatically change to match the Bank and Program numbers of the Program that you select for Local Program. For example, if you choose Program 178, then MIDI Bank will change to 1 and MIDI Program will change to 49.

MIDI Program

The MIDI Program parameter determines the MIDI Program change message that the currently selected Zone sends when the Multi is loaded. You can set this parameter to a MIDI Program change message from 0 to 127.

When using the Artis as a MIDI controller, sending a MIDI Program change message (along with a MIDI bank change message) when a Multi is loaded ensures that the Program loaded on the other sound modules in your MIDI chain is the Program that you want. For example, if you've configured a Multi to work in a specific way with Program 32 in Bank 5 of a connected sound module, then set MIDI Bank to 5 and MIDI Program to 32. This way, whenever you load this Multi, the sound module will automatically load Program 32 in Bank 5.

Pressing both Previous & Next buttons simultaneously will set this parameter to the Program number of the currently selected Local Program.



NOTE : When you change the Program parameter, the MIDI Bank and MIDI Program parameters will automatically change to match the Bank and Program numbers of the Program that you select for Local Program. For example, if you choose Program 178, then MIDI Bank will change to 1 and MIDI Program will change to 49.

Differing Program Numbers

If the Programs on your connected sound module are organized by MIDI Bank with each Program number being between 0 and 127, then use the following formula to determine what number to enter for the MIDI Program Change Function:

$$[MIDI\ Bank\ number] * 128 + [Program\ number]$$

So for example, if you want to send a MIDI Program Change message for Program 83 in MIDI Bank 4, you would enter the number 595—this number is equal to $4 * 128 + 83$.

If the Programs on your connected sound module are organized by MIDI Bank with each Program number being between 1 and 128, then use the following formula to determine what number to enter in MIDI Program Change Mode:

$$[MIDI\ Bank\ number] * 128 + [Program\ number] - 1$$

So for example, if you want to send a MIDI Program Change message for Program 83 in MIDI Bank 4, you would enter the number 594—this number is equal to $4 * 128 + (83 - 1)$.

Multi Edit Mode

Zone Parameters

Entry Program Change

The Entry Program Change parameter determines whether or not the currently selected Zone will send a MIDI Program change message when the Multi is loaded. You can set this parameter to either Off or On. When set to On, the Zone will send a MIDI Program change message with the Program specified for the MIDI Program parameter.

Pressing both Previous & Next buttons simultaneously will set this parameter to On.

Bank Mode

The Bank Mode parameter determines the controller number with which MIDI Bank change messages are transmitted. For MIDI Bank change messages, various manufacturers have chosen different MIDI controller numbers. Most have chosen 0, 32, or both. In the case of the Kurzweil K2600, it responds to controller 32, but is limited to 100 programs per bank. Pressing both Previous & Next buttons simultaneously will set this parameter to Ctl 0/32.

You can set this parameter to any of the following:

None	MIDI Bank change messages are disabled.
Ctl0	MIDI Bank change messages are sent with controller number 0.
Ctl32	MIDI Bank change messages are sent with controller number 32.
Ctl0/32	MIDI Bank change messages are sent with both controller numbers 0 and 32.
K2600	MIDI Bank change messages are sent with controller number 32. (K2600 Program numbers 0-99.)

Bend Range Down

The Bend Range Down parameter determines the lower bend of the Pitch Wheel. You can set this parameter to any value between 0 semitones and 127 semitones, or to Prog, which uses the Bend Range of the currently selected Program for the Zone. The Bend Range Down value can be entered numerically, and entering -1 will select Prog.

Pressing both Previous & Next buttons simultaneously will select Prog, which uses the value that the Program would use in Program Mode.

Bend Range Up

The Bend Range Up parameter determines the upper bend of the Pitch Wheel. You can set this parameter to any value between 0 semitones and 127 semitones, or to Prog, which uses the Bend Range of the currently selected Program for the Zone. The Bend Range Up value can be entered numerically, and entering -1 will select Prog.

Pressing both Previous & Next buttons simultaneously will select Prog, which uses the value that the Program would use in Program Mode.

CTRLS Page

Press the CTRLS soft button to view pages where you can set parameters for each of the Artis physical controllers. Press the soft buttons at the bottom of the screen to navigate to the page for each controller type. See the Continuous Controller Parameters section and Switch Parameters section below for details on these parameters.

WHEEL page

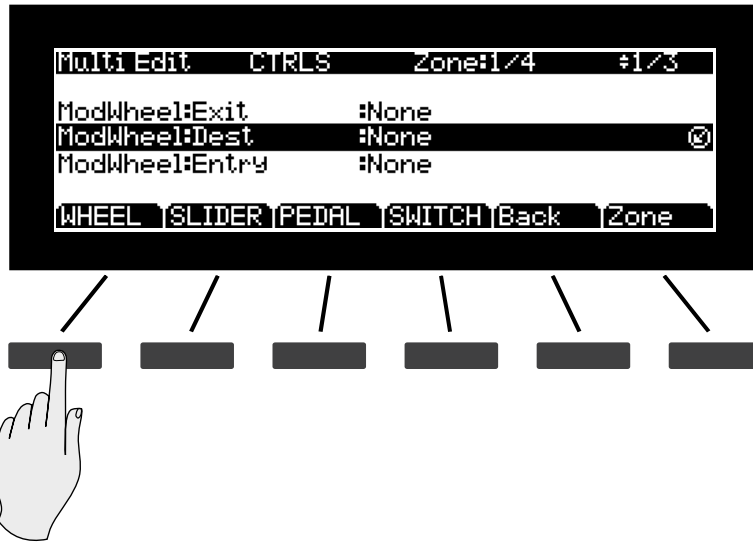

Parameter	Range Of Values	Default Value
ModWheel:Dest	Multi Destination Controller List	(none)
ModWheel:Entry	0 to 127	(none)
ModWheel:Exit	0 to 127	(none)

Multi Edit Mode

Zone Parameters

SLIDER page

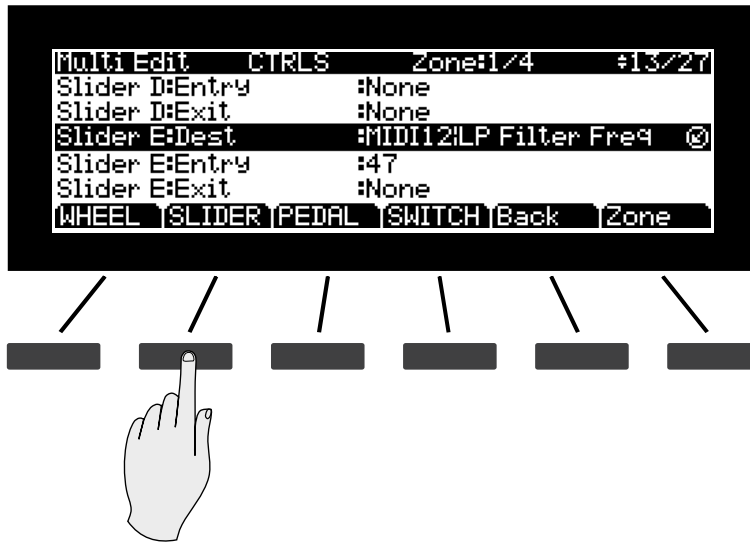

Parameter	Range Of Values	Default Value
Slider A to I Destination	Multi Destination Controller List	(none)
Slider A to I Entry Value	0 to 127	(none)
Slider A to I Exit Value	0 to 127	(none)

PEDAL page

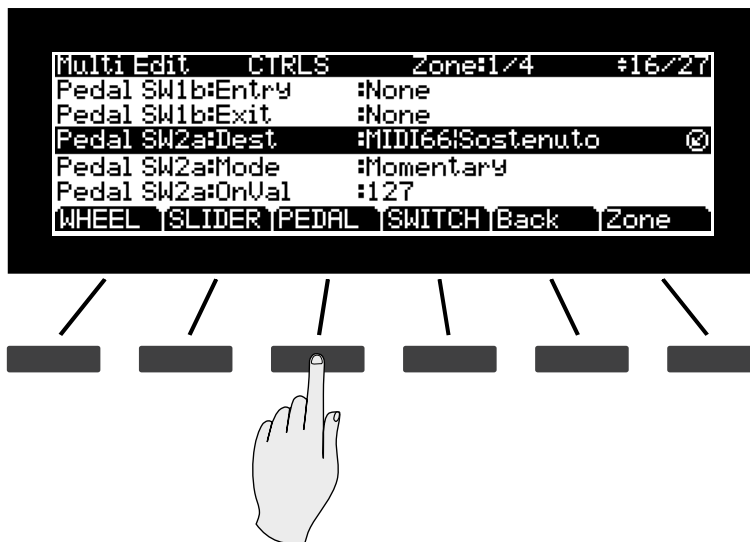

Parameter	Range Of Values	Default Value
CC Pedal Destination	Multi Destination Controller List	(none)
CC Pedal Entry Value	0 to 127	(none)
CC Pedal Exit Value	0 to 127	(none)
Pedal SW1a to Pedal SW2b Mode	Momentary, Toggled	Toggled
Pedal SW1a to Pedal SW2b Destination	Multi Destination Controller List	(none)
Pedal SW1a to Pedal SW2b On Value	0 to 127	127
Pedal SW1a to Pedal SW2b Off Value	0 to 127	0
Pedal SW1a to Pedal SW2b Entry State	None, On, Off	None
Pedal SW1a to Pedal SW2b Exit State	None, On, Off	None

SWITCHES page

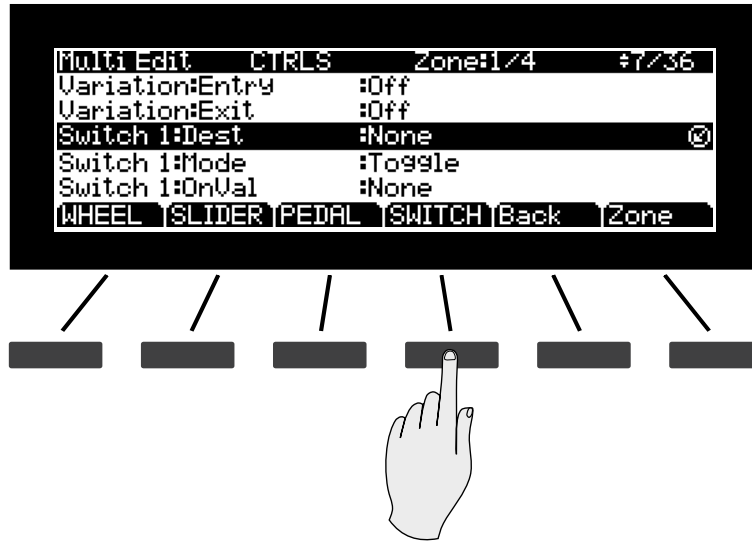

Parameter	Range Of Values	Default Value
Variation Mode	Momentary, Toggled	Toggled
Variation Destination	Multi Destination Controller List	(none)
Variation On Value	None, 0 to 127	127
Variation Off Value	None, 0 to 127	0
Variation Entry	None, On, Off	None
Variation Exit	None, On, Off	None
Switch 1 to 5 Mode	Momentary, Toggled	Toggled
Switch 1 to 5 Destination	Multi Destination Controller List	(none)
Switch 1 to 5 On Value	None, 0 to 127	127
Switch 1 to 5 Off Value	None, 0 to 127	0
Switch 1 to 5 Entry	None, On, Off	None
Switch 1 to 5 Exit	None, On, Off	None

The Switch Parameters

- Variation
- Switch 1 through 5
- Pedal SW1a to SW2b
- Variation button & Switch buttons 1 to 5

Assigning controllers to switches and buttons creates a Virtual Parameter in the same way as the continuous controllers. The following are parameters that affect the behavior of the Foot Switch and switch button controllers:

Mode

The Mode parameter determines the switching behavior of Foot Switches and buttons.

Momentary	A momentary switch is one that is only in the “on” state when it is pressed. As soon as you release the switch, it goes into the “off” state.
Toggled	A toggled switch is one that maintains its state after it is pressed. So, if the switch is currently in the “off” state, pressing it once will put it in the “on” state. Pressing it again will put it back in the “off” state.

Pressing both Previous & Next buttons simultaneously will set this parameter to Toggled.

Dest (Destination)

The Destination parameter determines the Controller Destination for the currently selected controller in the currently selected Zone. For a list of the Multi Destination Controllers and their descriptions, see Destination on page 8-19.

Pressing both Previous & Next buttons simultaneously will cycle this parameter through these common settings: ModWheel, Volume, Sustain, DataInc, Pitch, ProgInc, TransUp, Off.

On Value

The On Value is the MIDI value sent when the switch is set to On. You can set this parameter to any number between 0 and 127, or to None.

Pressing both Previous & Next buttons simultaneously will set this parameter to 127.

Off Value

The Off Value is the MIDI value sent when the switch is set to Off. You can set this parameter to any number between 0 and 127, or to None.

Pressing both Previous & Next buttons simultaneously will set this parameter to 0.

Entry State

The Entry State parameter determines the state of the Foot Switch or button that is sent as a MIDI message when the current Multi is loaded. You can set this parameter to None, On, or Off.

Pressing both Previous & Next buttons simultaneously will set this parameter to None. None can be entered with the alphanumeric function of the Program/Multi buttons as -1.

If Entry State is set to None, then when you load the current Multi, no value will be transmitted. If you specify an Entry State, then a MIDI controller message with this value will be sent when you load the current Multi.

Exit State

The Exit State parameter determines the state of the Foot Switch or button that is sent as a MIDI message when the current Multi is exited. You can set this parameter to None, On, or Off.

Pressing both Previous & Next buttons simultaneously will set this parameter to None. None is entered with the alphanumeric function of the Program/Multi buttons as -1.

If Exit State is set to None, then when you leave the current Multi by selecting another Multi or Program, the Foot Switch or button will remain at whatever value corresponds to its current position. If you specify an Exit State, then a MIDI controller message with this value will be sent when you close the current Multi.

Continuous Controller Parameters

- ModWheel
- Slider A through I
- CC Pedal

Dest (Destination)

Use the Destination parameter to assign the Artis physical controllers (Sliders, Pedals, Switches, Mod Wheel, etc.) to control Program parameters or send MIDI continuous controller messages (CCs) to external MIDI gear.

The Destination parameter determines the MIDI CC controller number that a physical controller will send to the Program in the currently selected Zone. By default, these CC messages are also sent to the MIDI Out and USB ports on the Channel of that Zone.

The list of CC controller numbers below shows the default assignments for each destination. Programs respond to some of these CCs to do standard MIDI functions like volume and panning. Other external MIDI gear (sound modules, computer software) may respond to standard MIDI CC messages as well.

Multi Edit Mode

Zone Parameters

Controlling Program Parameter Assignments from Multi Mode

Commonly you will want to assign a physical controller in a Multi to control the same Program parameter that it controlled in Program Mode. In the Dest parameter list, destinations that are assigned to parameters for the Program of the current Zone will show the Program Parameter name to the right of the Destination Name. Select one of these destinations to control an assigned Program parameter

Program parameter assignment

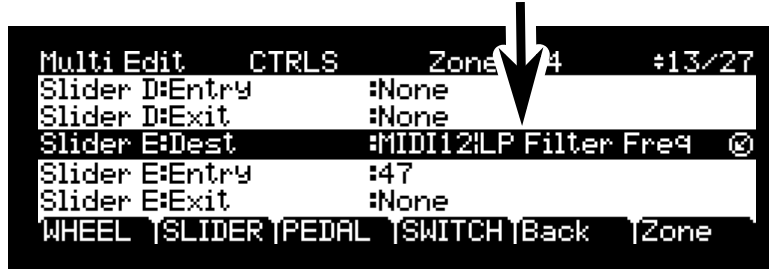

Controller Number	Controller Destination	Description
0	OFF/Bank	By default, when you enter 0 or Clear for the Destination parameter, the destination will be assigned to OFF. To select Bank as the destination, use the Value buttons.
1	MWheel	Default destination for the Modulation Wheel
2	Breath	Default assignment for breath controller in compatible synths
3	MIDI 03	MIDI Controller 3
4	Foot	Default assignment for continuous foot controller in compatible synths
5	PortTim	Monophonic Artis Programs respond to this Controller if portamento is turned on.
6	Data	MIDI Controller 6
7	Volume	MIDI Volume
8	Balance	MIDI Balance
9	MIDI 09	MIDI Controller 9
10	Pan	MIDI Pan
11	Express	Default assignment for CC Pedal. In most Programs it acts as a volume control. It scales between 0 and the current value of Volume.
12	MIDI 12	Default assignment for Slider A
13	MIDI 13	Default assignment for Slider B
14-21	MIDI 14-21	MIDI Controllers 14-21
22	MIDI 22	Default assignment for Slider C
23	MIDI 23	Default assignment for Slider D
24	MIDI 24	Default assignment for Slider E
25	MIDI 25	Default assignment for Slider F
26	MIDI 26	Default assignment for Slider G
27	MIDI 27	Default assignment for Slider H
28	MIDI 28	Default assignment for Slider I
29	MIDI 29	Default assignment for Variation switch
30-31	MIDI 30-31	MIDI Controllers 30-31

Multi Edit Mode

Zone Parameters

Controller Number	Controller Destination	Description
32	MIDI Bank	MIDI Bank change message
33–63	MIDI 33–63	MIDI Controllers 33–63
64	Sustain	Default destination for Sustain Pedal
65	MIDI 65	
66	Sostenuto	Default destination for Sostenuto Pedal (Sustains notes that are currently down, but not notes played subsequently.)
67	Soft	Lowers the volume by a preset amount and may soften the timbre as well.
68	Legato	Forces mono playback.
69	Freeze	Envelopes freeze at current state.
70–79	MIDI 70–79	MIDI Controllers 70–79
80	MIDI 80	Default assignment for Switch 1
81	MIDI 81	Default assignment for Switch 2
82	MIDI 82	Default assignment for Switch 3
83	MIDI 83	Default assignment for Switch 4
84	Portamento	Standard MIDI controller for setting Portamento starting note
85	MIDI 85	Default assignment for Switch 5
86	MIDI 86	Default assignment for Switch 6 (KB3 only)
87	MIDI 87	Default assignment for Switch 7 (KB3 only)
88	MIDI 88	
89	MIDI 89	Default assignment for Switch 8 (KB3 only)
90	MIDI 90	Default assignment for Switch 9 (KB3 only)
91–95	MIDI 91–95	MIDI Controllers 94–95
96	Data Inc	Equivalent to pressing the Next Value button
97	Data Dec	Equivalent to pressing the Previous Value button
98	NRegParL	Non-Registered Parameter Least Significant Byte
99	NRegParM	Non-Registered Parameter Most Significant Byte
100	RegParL	Registered Parameter Least Significant Byte
101	RegParM	Registered Parameter Most Significant Byte
102–119	MIDI 102–119	MIDI Controllers 102–119
120	Sound Off	Stops all sound in the corresponding channel.
121	RstCtls	Resets Controllers to defaults in the corresponding channel.
122	Local	
123	Notes Off	Sends Note Off Message to all playing notes in the corresponding channel.
124	Poly	
125	Omni	
126	Mono On	
127	Mono Off	
128	Pitch	Values above 64 and below 64 bend the pitch up and down, respectively.
129	PitchRev	Values above 64 and below 64 bend the pitch down and up, respectively
130	PitchUp	Values above 0 bend the pitch up
131	PitchDwn	Values above 0 bend the pitch down
132	Pressure	
133	Tempo	Tempo

Multi Edit Mode

COMMON Page

Controller Number	Controller Destination	Description
134	KeyNum	Triggers playback of notes by Key Number—e.g., C4 is 60. Send a velocity first with Destination135, KeyVel.
135	KeyVel	Key Velocity
136	ProgInc	Program Increment—increments current Program number.
137	ProgDec	Program Decrement—decrements current Program number.
138	ProgGoto	Go to Program—selects Program.
139	MultiInc	Multi Increment—increments current Multi number.
140	MultiDec	Multi Decrement—increments current Multi number.
141	SetpGoto	Go to Multi—selects Multi.
145	TransUp	Transpose Up (ST)
146	TransDown	Transpose Down (ST)

Entry Value

The Entry Value parameter determines the value of the continuous controller that is sent as a MIDI message when the current Multi is loaded. You can set this parameter to any number between 0 and 127, or to None.

Pressing both Previous & Next buttons simultaneously will set this parameter to None.

If Entry Value is set to None, when you load the current Multi, no value will be sent. If you specify an Entry Value, then a MIDI controller message with this value will be sent when you load the current Multi.

Exit Value

The Exit Value parameter determines the value of the continuous controller that is sent as a MIDI message when the current Multi is exited. You can set this parameter to any number between 0 and 127, or to None.

Pressing both Previous & Next buttons simultaneously will set this parameter to None.

If Exit Value is set to None, then when you leave the current Multi, the controller will remain at whatever value corresponds to its current position. If you specify an Exit Value, then a MIDI controller message with this value will be sent when you close the current Multi.

COMMON Page

In addition to the Zone-specific parameters described above, a Multi has parameters common to all of its Zones.

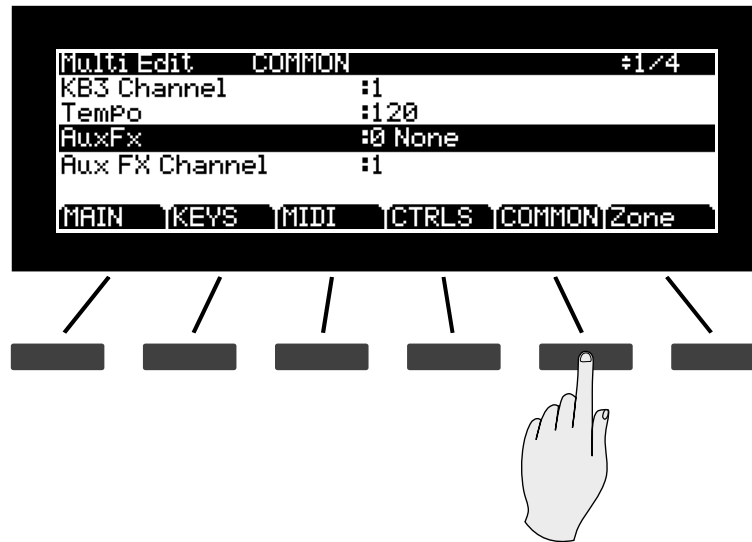

Parameter	Range Of Values	Default Value
AuxFX	(List of Effects)	none
Aux FX Channel	(Channels used in Multi)	(Channel of Zone 1)
KB3 Channel	1 to 16	(Channel of Zone 1)
Tempo	20 - 320	120

AuxFX

Use the AuxFX parameter to select an Aux Effect Chain from the list that can be accessed by all Programs in the current Multi. Setting this parameter to anything other than “0 None” uses the selected Chain for the Aux Effect, and the Chain selected by the Aux FX Channel parameter is disabled. When the AuxFX parameter is set to “0 None”, the Aux Effect Chain for the Multi is determined by the Aux FX Channel parameter (described below.)

Aux FX Channel

In Program Mode, each Program has its own factory set Aux Effect Chain. Use the AuxFX Channel parameter to use a Program’s factory set Aux Effect Chain in Multi Mode. All programs in a Multi share one Aux Effect Chain.

To use a Program’s factory set Aux Effect Chain in Multi Mode, set the Aux FX Channel parameter to the MIDI channel of the Zone containing that Program.

If the AuxFX parameter is set to something other than “0 None”, the Chain selected with Aux FX Channel parameter is disabled. See the AuxFx parameter above for details.

KB3 Channel

In the event there are more than one KB3 Programs specified in a Multi, this parameter specifies which MIDI Channel has priority to load a KB3 Program. You can set this parameter to a value between 1 and 16. Pressing both Value buttons simultaneously will set this parameter to the channel in Zone 1.

Tempo

Sets the Tempo to a value between 20 and 320 beats per minute.

Pressing both Previous & Next buttons simultaneously will set this parameter 120.

About Auxiliary Effects

Programs and Multis both have an auxiliary effect. An auxiliary effect is an effect that is not in the direct path of the sound, but rather, it “receives” and processes the sound applying the effect, which is mixed back with the original sound. The following diagram illustrates the signal path of a sound through the auxiliary effect:

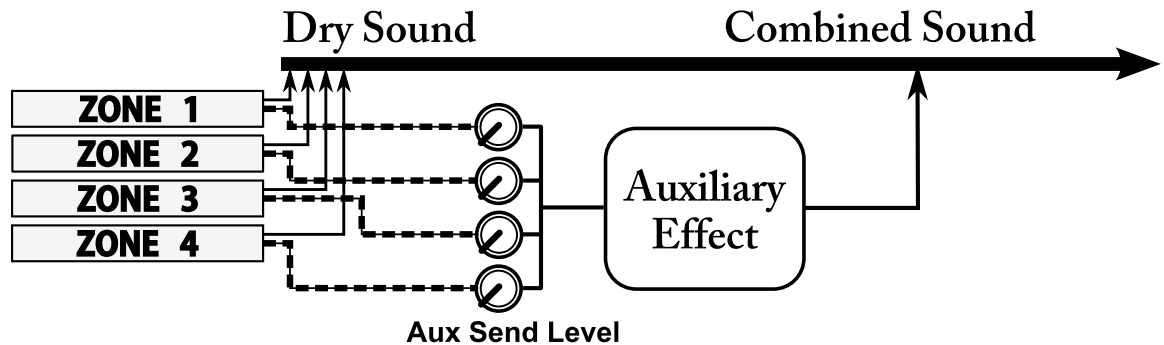

The Aux Send Level parameter (on each CH/PRG Zone page) determines the level the auxiliary effect will process the sound for that Zone.

Save and Delete User Multis

For details on saving and deleting user Multis, See the Save and Delete User Multis section on page 7-16 of the Multi Mode chapter.

Chapter 9

Global Mode

This chapter will help familiarize you with the features of Global Mode.

About Global Mode

Global Mode gives you access to the global parameters of the Artis. It allows you to edit the master settings of the unit. It also allows you to restore factory defaults on the unit by performing a Hard or Soft Reset.



CAUTION: Performing a Hard Reset will erase ALL User Programs, User Multis and reset Global settings to a factory state.

To enter Global Mode from another Mode, press the Global Mode button.

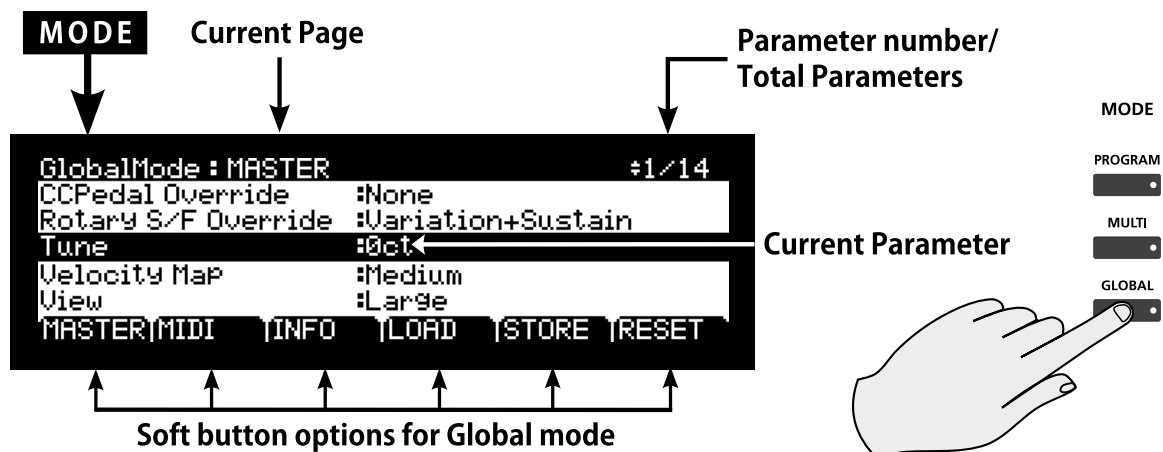

While you are in Global Mode, the Global button's indicator LED is lit.

Global Mode

Selecting and Editing Parameters

When you enter Global Mode, the last selected parameter since power-up (or the Tune parameter if you're entering Global Mode for the first time since power-up) will be the currently selected parameter.

Selecting and Editing Parameters

To scroll through the parameters of Global Mode, use the Param / Channel buttons.

First, using the buttons underneath the display, select the page you need.

To edit the currently selected parameter, use the Alpha Wheel or the Previous and Next buttons. Pressing both Previous & Next buttons simultaneously (called Value Jump) will jump to a different value depending on the parameter selected. The jump value is mentioned in each of the parameter descriptions below.

MASTER Page

The MASTER page in Global Mode allows you to set up the feel and response of the keyboard to your playing style, how effects are applied, tuning and the way things are displayed on the Artis LCD display.

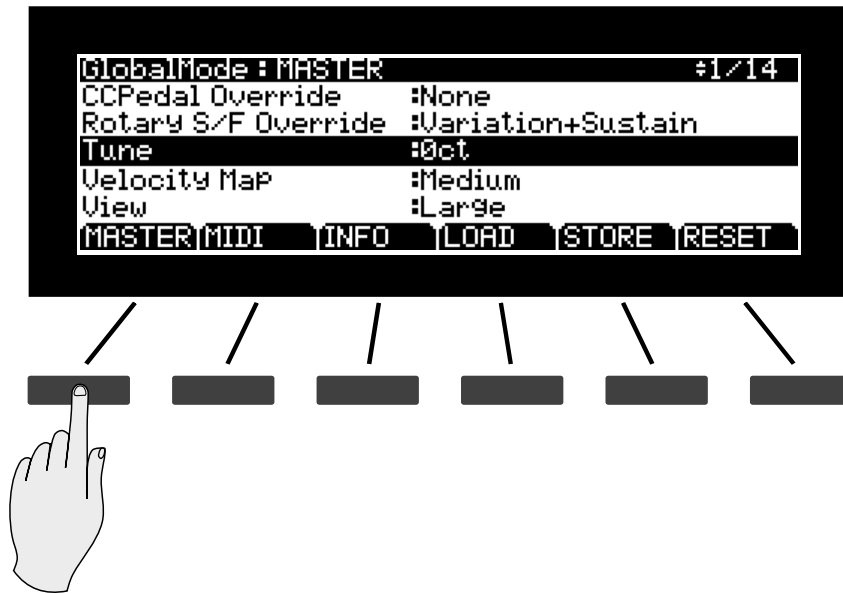

Parameter	Range of Values	Default Value
Tune	-100 to 100 Cents	0 Cents
Velocity Map	Lightest, Lighter, Light, Medium, Hard, Harder, Hardest, Piano Touch, Easy Touch, GM Receive	Medium
View	Large, Grid	Grid
FX Select (FXSel)	Performance, Multitrack	Performance

Parameter	Range of Values	Default Value
Auto Power Off	On, Off	On
Auto Power Off Time	15 min, 30 min, 1 hr, 2 hr, 4 hr	30 min
Auto Power Off Message	Show, Skip	Show
Pedal Noise	On, Off	On
Pedal SW1a Override	None, Sustain, Sostenuto, Soft, DataInc, DataDec, FavoriteInc, FavoriteDec	None
Pedal SW1b Override	None, Sustain, Sostenuto, Soft, DataInc, DataDec, FavoriteInc, FavoriteDec	None
Pedal SW2a Override	None, Sustain, Sostenuto, Soft, DataInc, DataDec, FavoriteInc, FavoriteDec	None
Pedal SW2b Override	None, Sustain, Sostenuto, Soft, DataInc, DataDec, FavoriteInc, FavoriteDec	None
CC Pedal Override	None, Mwheel, Foot/Way, Volume, Expression, Pressure	None
Rotary S/F Override	Variation+Sustain, Variation	Variation+Sustain

Tune

The Tuning parameter allows you to fine-tune the unit in cents—one cent is one hundredth of a semitone (100 cents comprise a semitone). You can select any tuning from -100 cents to 100 cents. By default this parameter is set to 0.

Pressing both Previous & Next buttons simultaneously will set this parameter to 0.

Velocity Map

The Velocity Map parameter determines the way the Artis generates MIDI velocity information. Different maps generate different MIDI velocity values for the same physical key strike velocity.

The default map (Medium) provides the widest range of velocity expression, but you may want to choose a different map if the default does not suit your playing style. You can select from any of the following settings:

Lightest Lighter Light	Makes it increasingly easier to produce high MIDI velocity values for the same key strike velocity (with Lightest being the easiest). These maps work best for those with a light touch.
Medium	The Artis default map. Medium, allows MIDI velocities to pass unchanged. It follows a linear response.
Hard Harder Hardest	Makes it increasingly harder to produce high MIDI velocity values for the same key strike velocity (with Hardest being the hardest). These maps work best for those with a heavy touch.

Global Mode

MASTER Page

Piano Touch	Simulates the general velocity response of an acoustic piano, and is best suited for playing acoustic piano programs.
Easy Touch	Similar to the Light/Lighter/Lightest settings. Makes higher velocities easier to play, but allows more sensitive control over playing high velocities by not boosting the MIDI velocity for fast strike velocities as much as it does for medium strike velocities.
GM Receive	Mimics the velocity response commonly used by keyboards that use the General MIDI (GM) sound set. The GM Receive map makes medium strike velocities produce higher MIDI velocities compared to the Medium map.

Pressing both Previous & Next buttons simultaneously will set this parameter to Medium.

View

The View parameter allows you to change the way that Programs and Multis are displayed. The standard default view is Large. The screen shot below shows the View parameter set to Grid.



FX Select (FXSel)

The FX Select (FXSel) parameter determines how the Artis responds to interrupts with regards to effects. You can set this parameter to either Performance or Multitrack.

With FX Select set to Performance, the Artis minimizes disruption of existing effects when changing Programs, and entry values will not disrupt sustained notes when changing Programs in Program Mode.

When controlling the Artis from an external sequencer in Program Mode, setting FX Select to Multitrack will minimize effect disruption.

Pressing both Previous & Next buttons simultaneously will set this parameter to Performance.

Auto Power Off

The auto power off parameter turns the power saving feature on. When the Auto Power Off parameter is set to Enable, the Artis will automatically power off after the Auto Power Off Time has expired, from the last key press (physical or MIDI), button press, controller movement, or USB MIDI activity.

Auto Power Off Time

If the Auto Power Off parameter is set to Enable, then the Artis will power off after the time selected by the Auto Power Off Time parameter has elapsed.

The Artis will display the following warnings before powering off. Press a key or move any Artis control to dismiss the warning message. After dismissing this message, the Artis will wait the selected amount of time before showing this warning again.

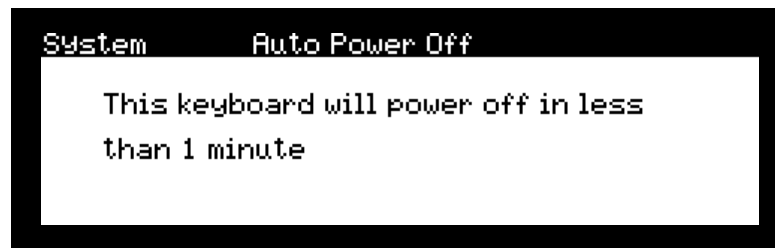
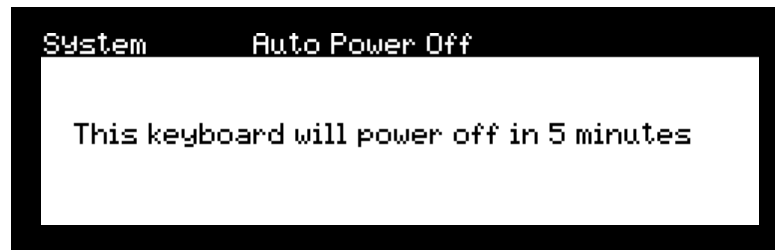

Auto Power Off Message

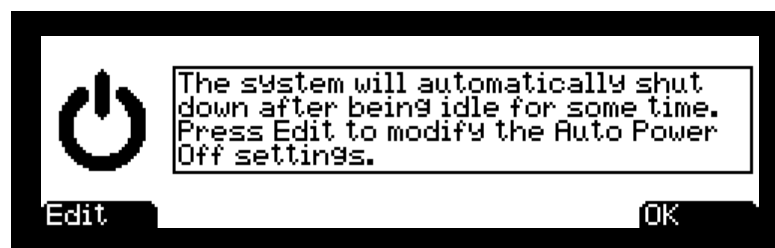

This parameter determines whether a reminder message is shown during boot up of the Artis, reminding you that the Artis will power off after a period of inactivity. By default this setting is set to Show, and the other option is to Skip. If Auto Power Off (page 9-5) is set to Disable, then this parameter has no effect, and no message is shown during the boot cycle.

Pedal Noise

Some piano Programs have a Pedal Noise feature programmed into the sound. This parameter allows you to turn the Pedal Noise off if you prefer not to use it. If it is on, it will only activate noise on those Programs that have been programmed to use it.

Pedal Switch Overrides

The Pedal SW Overrides allow the default controller assignments for the Switch Pedals to be changed. This applies both to Programs and to the default behaviour of the Multis. The alternative controllers available for the Pedal Switch Overrides include the standard Pedal controls of Sustain, Sostenuto and Soft and also includes performance orientated controls of DataInc, DataDec, FavoriteInc and FavoriteDec, which can be used to change Programs, Multis or Favorites, from a Foot Switch.

When using FavoriteInc and FavoriteDec, if you are playing a Favorite, when you depress the Pedal, the next Favorite will be loaded, with the last Favorite wrapping back around to the first favorite. If you are not playing any Favorites, the Pedal will load the first Favorite.

Pedal Switch Overrides are available for all four of the possible Pedal Switches. If a Pedal has a Global Pedal Override different from None, then in Multi Edit Mode, the Destination of the Pedal will be shown in parenthesis. Also, in Multi Mode a Pedal Switch Override will automatically set the Pedal Mode to Momentary, and the OnVal and OffVal to 127 and 0 respectively.

In Multi Edit Mode, setting a Pedal Destination to “None” will disable the override for that Pedal in the selected Zone. It can be useful in Multi Mode to disable the Pedal Override for some Zones. For example, you may want to use a Pedal Override to control Sustain in all Zones of a Multi, but disable Sustain for one Zone containing an organ Program.

When a Pedal Switch Override is set to Sustain, Sostenuto or Soft, the Pedal type will automatically be set to Momentary. When set to DataInc, DataDec, FavoriteInc or FavoriteDec the Pedal Type will be set to Toggle.

CC Pedal Override

In a similar manner to Pedal Switch Overrides, the Continuous Control Pedal can be set to alternatives defaults. In this case the controllers that the CC Pedal can be set to are: Mod Wheel (MIDI CC 1), Foot/Wah (MIDI CC 4), Volume (MIDI CC7), Expression (MIDI CC11) and Pressure.

Rotary S/F Override

By default KB3 programs have the rotary speaker speed control assigned to the Variation Button, and to any connected Switch Pedal assigned to control Sustain. This setting can allow the behavior of any Switch Pedal assigned to Sustain to be changed between controlling only Sustain or controlling both Sustain and rotary speaker speed control. Variation will always control the rotary speed, regardless of this setting.

MIDI Page

The Artis can transmit and receive MIDI via its MIDI ports and USB. The MIDI page in Global Mode allows you to configure how this will be handled.

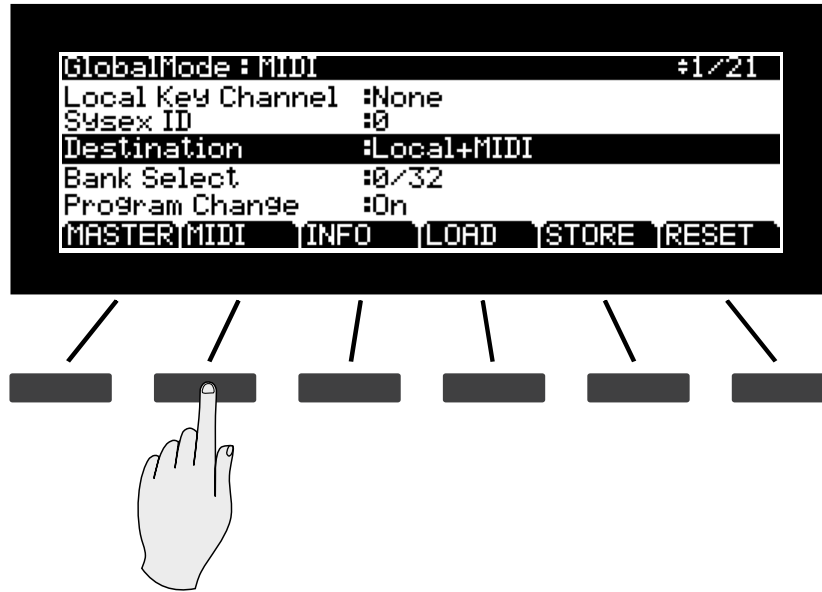

Parameter	Range of Values	Default Value
Destination (Destination)	Local, MIDI, Local+MIDI	Local+MIDI
Bank Select (BankSelect)	0, 32, 0/32	0/32
Program Change (ProgramChange)	On, Off	On
Channel Enable (Chan1-16)	Enable, Disable (For each Channel)	Enable (On all Channels)
Local Keyboard Channel (LclKbdChan)	None, 1 to 16	None
SysEx ID	0 to 127	0

Destination

The Destination parameter determines the destination of MIDI data generated by striking keys or activating controllers. This data can be sent to the Artis sound engine, through the MIDI out ports, or both. You can set this parameter to any of the three destinations for this parameter:

Note that this parameter is always active and works in conjunction with the Multi Mode Destination parameter (see page 8-7). These parameters act like filters, so if the Multi Mode Destination parameter is set to Local + MIDI and the Global Mode parameter is set to Local, the MIDI data will only be transmitted locally.



NOTE : MIDI OUT applies to the 5-pin MIDI OUT and USB ports.

Local	MIDI data is sent only to the Artis sound engine. MIDI Out is disabled.
MIDI	MIDI data is sent only through MIDI Out. The sounds of the Artis are disabled
Local+MIDI	MIDI data is sent both to the Artis sound engine and through the MIDI Out.

If you want to play the Artis, but not send any MIDI information to other MIDI instruments, then select Local.

If you want to use the Artis strictly as a MIDI controller for the other modules in your MIDI chain, then select MIDI.

If you want to make use of the Artis's sounds as well as use it as a MIDI controller, then select Local+MIDI.

Pressing both Previous & Next buttons simultaneously will set this parameter to Local+MIDI.



CAUTION: It is possible to stop all MIDI transmission, in Multi Mode, if one Destination parameter is set to Local, and the other is set to MIDI.

Bank Select (BankSelect)

The Bank Mode parameter determines the controller number with which MIDI Bank change messages are received.

For MIDI Bank change messages, various manufacturers have chosen different MIDI controller numbers. Most have chosen 0, 32, or both. You can set this parameter to any of the following three controller IDs:

0	MIDI Bank change messages are sent with controller number 0.
32	MIDI Bank change messages are sent with controller number 32.
0 / 32	MIDI Bank change messages are sent with both controller numbers 0 and 32.

Pressing both Previous & Next buttons simultaneously will set this parameter to 0/32.

Program Change

When Program Change (ProgChg) is set to On, the Artis sends program change commands to its USB or MIDI port when you select Programs/Multis from the front panel, or from your MIDI controller. Select a value of Off when you want to change Programs/Multis on the Artis but don't want to send program change commands to the USB or MIDI out port.

Pressing both Previous & Next buttons simultaneously will set this parameter to On.



NOTE : When you perform a MIDI Program Change through MIDI Program Change Mode, the setting of the Global Program Change parameter (as well as the setting of the Global Destination parameter) is ignored.

Channel Enable (ChanEn)

For each of the 16 MIDI channels, you can set the Channel Enable (ChanEn) parameter to either Enable or Disable. For each channel, setting this parameter to Enable enables the channel to transmit and receive MIDI messages and setting it to Disable disables such functions.

Pressing both Previous & Next buttons simultaneously will set this parameter to Enable.

Local Keyboard Channel (Local Key Channel)

Changing the setting of the Local Keyboard Channel parameter is useful only when the Artis is receiving MIDI information from an external source. Perhaps you have a favorite MIDI keyboard that you use to control all the gear in your studio, or you use a lot of outboard sequencing. If you're using the Artis as a standalone music workstation or performance keyboard, you can ignore this parameter and leave it set to None.

The local keyboard channel enables the Artis to receive MIDI information on a single channel, then rechannelize that information so you can play and control all four Zones of a Multi, even if your MIDI source transmits on only one channel.

Program Mode

When you're in Program Mode, the local keyboard channel remaps incoming information to the Artis's current channel. When using the local keyboard channel all the MIDI information received on the Local Keyboard Channel also gets sent, after being remapped to the Artis's MIDI Out and USB ports.

You may find it more convenient to use the local keyboard channel. In this case, the Artis remaps incoming MIDI to the Artis's current channel, so in Program Mode, you'll always play the Program on the Artis's current channel. Incoming MIDI also gets sent to the Artis's MIDI Out and USB port. When this parameter is set, you will need to transmit on the local keyboard channel from your DAW or controller keyboard for the Artis to respond correctly.

Multi Mode

Things are a bit different for playing Multis. In this case, you must use the Local Keyboard Channel to be able to play and control all of the Multis Zones. Set Local Key Channel to match the channel your external MIDI source is using (if for example your MIDI source transmits on Channel 1, set Local Key Channel to 1). All MIDI information that the Artis receives on the local keyboard channel gets remapped to the channels and control destinations used by the Zones in the Multi.

The Artis also remaps certain MIDI Controller messages that it receives on the Local Keyboard Channel, so that they correspond (in most cases) to the default assignments for the Artis's physical controllers (Mod Wheel, sliders, etc.). Physical controller assignments are handled by Multis, and are defined per Zone in Multi Edit Mode. Each Zone of a Multi has its own controller assignments.

Pressing both Previous & Next buttons simultaneously will set this parameter to None.

Sysex ID

The SysEx ID parameter determines the ID number for the unit if you are using more than one device with the same MIDI manufacturer ID number. You can set this parameter to any number from 0 to 127.

Unless you have multiple Artis keyboards receiving Sysex messages from a single source, you will not need to change the Sysex ID from the default setting of 0.

If you do have multiple Artiss receiving Sysex messages from a single source, make sure each Artis has a different Sysex ID. This will allow you to direct Sysex messages to the appropriate Artis by specifying which unit with the Sysex ID byte that's included with every Sysex message.

To have the unit respond to Sysex messages regardless of the Sysex ID, set Sysex ID to 127.

Pressing both Previous & Next buttons simultaneously will set this parameter to 0.

Global Mode

INFO Page

INFO Page

The INFO page contains the system information indicating what version of operating system and objects is currently installed in your Artis keyboard.

Go to the Kurzweil website at <http://www.kurzweil.com> and make sure that you have the latest operating system available.

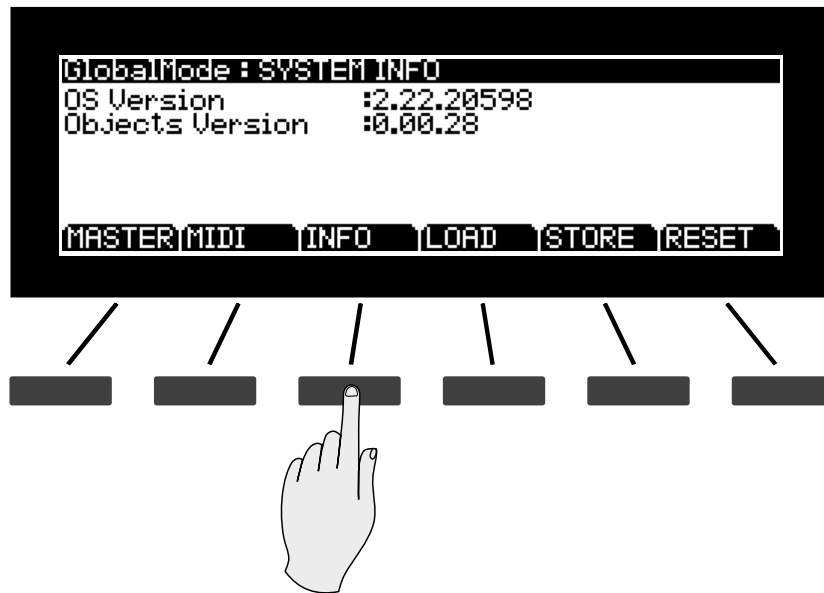

LOAD Page

The LOAD button allows you to load a file containing previously saved User Programs and User Multis from a computer or storage device connected to the Artis via USB.

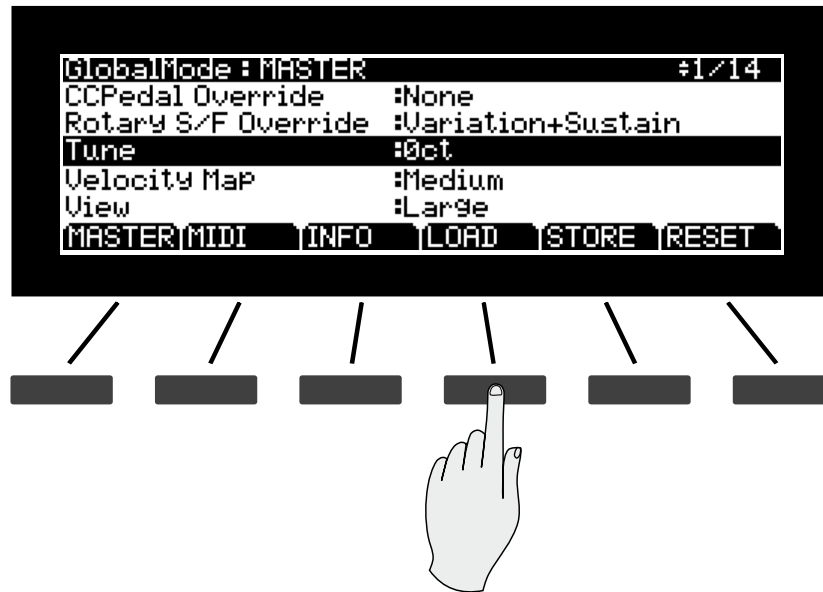

NOTE : If Artis is currently connected to your computer as a MIDI controller, eject or Safely Remove it before continuing. Selecting the Load page will disconnect any MIDI device connected via USB.

Before you press the LOAD selection button in Global Mode, make sure you have plugged the USB device containing your User Programs and/or Multis into the back of the Artis.

If your User Programs/Multis are located on your computer or Tablet, then use the cable that plugs into the computer/Tablet USB port on the rear panel of Artis.

If your User Programs/Multis are located on a USB flash drive, plug them into the Device USB port on the rear panel of Artis.

It is important for you to be aware of what USB port you have plugged into on Artis, as it will ask you from which USB port to load sounds from.

Pressing LOAD

Press the LOAD button when you have the hardware containing your User Programs/Multis plugged into the USB port.

Global Mode

LOAD Page

The next LOAD screen requires you to select which USB port to look for the hardware containing your User Programs/Multis.

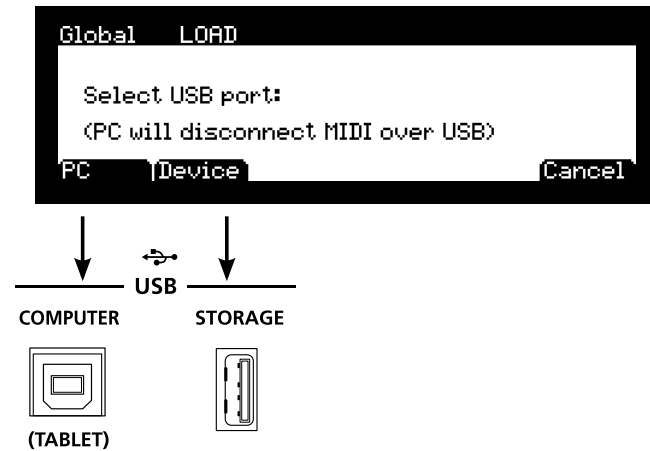

Choose PC if you are plugged into the computer/Tablet USB port.

Choose Device if you are plugged into the Storage USB port.

Selecting Cancel exits the loading screen without loading any sounds.

If no USB connection is detected by the Artis, you will see the following screen. In this case you will need to now connect your USB cable to either the the computer/Tablet or Device USB slot.

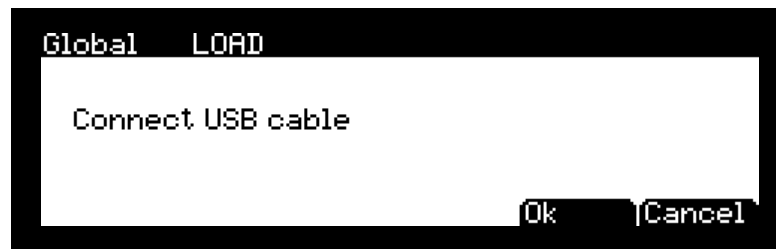

Selecting PC

If have you chosen PC, you have selected to load User Programs/Multis from either your computer or Tablet. The Artis will now create a temporary folder on your computer/Tablet.



Drag and drop the User Programs/Multis into the temporary folder on your computer/Tablet.

You now have the option how the User Programs/Multis will be loaded into Artis. Selection is either FILL or OVWRTE.



OPEN	Selecting Open will open a selected folder.
PARENT	Selecting Parent will close an existing open folder.
FILL	Selecting FILL means you would like to keep the existing Programs or Multis. Artis will now load the User Programs/Multis into the first empty ID slot it finds, and then subsequent empty slots.
OVERWRITE (OVWRTE)	Selecting OVWRTE first deletes all the existing User Programs or Multis, and then loads the new User Programs or Multis into the first user location at ID number 257 onwards.

Select which method you would like to use. Press Cancel if you would like to abort.



Press OK when the file has loaded.

Global Mode

LOAD Page

Selecting Device

If you have chosen Device, the Artis shows a screen listing files on the device.



OPEN	Selecting Open will open a selected folder.
PARENT	Selecting Parent will close an existing open folder.
FILL	Selecting FILL means you would like to keep the existing Programs or Multis. Artis will now load the User Programs/Multis into the first empty ID slot it finds, and then subsequent empty slots.
OVERWRITE (OVRWRTE)	Selecting OVRWRTE first deletes all the existing User Programs or Multis, and then loads the new User Programs or Multis into the first user location at ID number 257 onwards.

Select which method you would like to use. Press Cancel if you would like to abort.



Press OK when the file has loaded.

USB connection errors

If no file is in the Artis temporary drive during the load or an error occurs during the load operation, then the display will show the error message, "Load Error" and a message specifying the reason for the error.

STORE Page

The STORE button allows you to save a file containing User Programs and User Multis currently in the Artis to a computer or storage device connected via a USB connection.

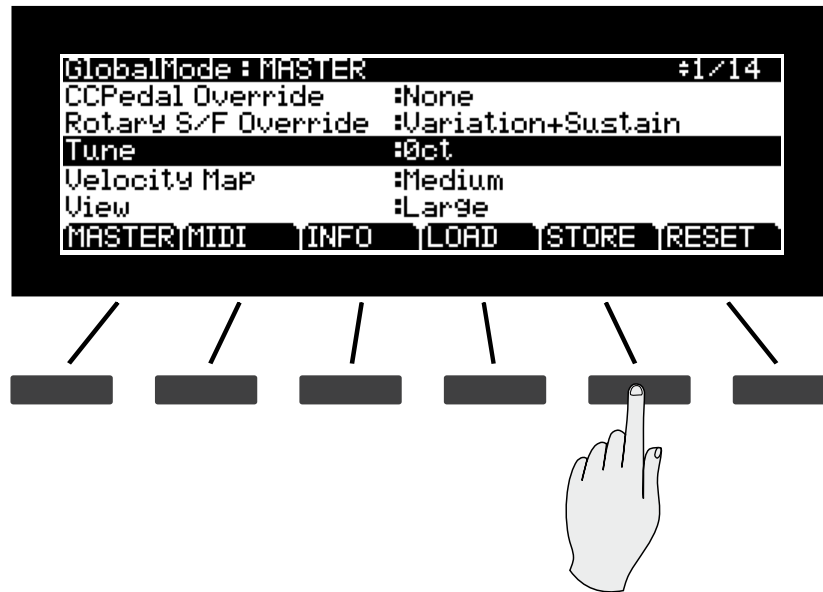

NOTE : If Artis is currently connected to your computer as a MIDI controller, eject or Safely Remove it before continuing. Selecting the Store page will disconnect any MIDI device connected via USB.

Before you press the STORE selection button in Global Mode, make sure you have plugged the USB device into the Artis.

If you are saving sounds to your computer or Tablet, then use the cable that plugs into the computer/Tablet USB port on the rear panel of the Artis.

If you are saving sounds to a USB flash drive, plug them into the Device USB port on the rear panel of the Artis.

It is important for you to be aware of what USB port you have plugged into on the Artis, as it will ask you which USB port to store sounds to.

Pressing STORE

Press the STORE button when you have a storage device plugged into a USB port.

The next STORE screen requires you to select which USB port you will be using to save your User Programs/Multis.

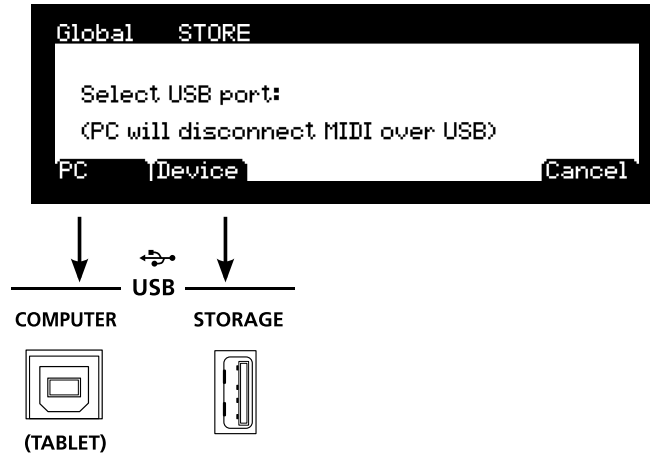

Choose PC if you are saving to a computer.

Choose Device if you are saving to a USB flash drive.

Selecting Cancel exits the loading screen without loading any sounds.

If no USB connection is detected by the Artis, you will see the following screen. In this case you will need to now connect your USB cable to either the the computer/Tablet or Device USB slot.

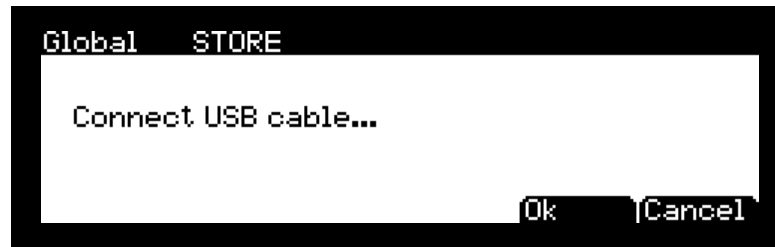

After selecting the USB destination you wish to store your sounds to, the Artis will now prompt you to enter a save file name.



Use the alphanumeric function of the Program/Multi buttons to enter a file name (8 character limit) and press Save. Select Cancel if you do not wish save anything and exit. The Artis uses the file extension of ART.



RESET Page

The RESET button allows you to reset the Artis back to varying default states. You can reset just the Global Mode parameters, or all user Programs and user Multis along with the Global parameters.



CAUTION: Be aware that performing any form of reset on the Artis will result in changes that can not be reversed. Kurzweil recommends that you save (STORE) all your Programs and Multis that you wish to keep before performing any type of reset on the Artis.

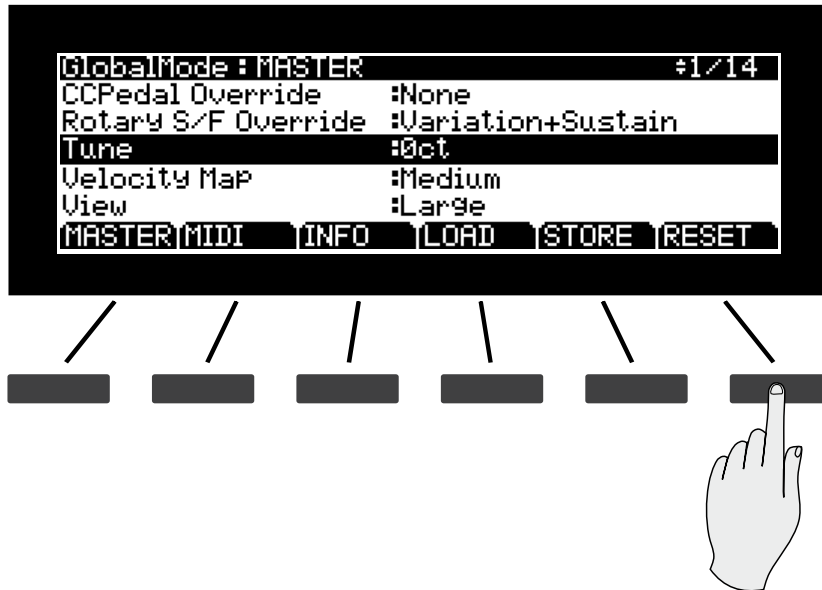

Press the RESET button to enter the reset process. You can CANCEL at any time if you are unsure, or do not want to proceed.

Reset Global Mode parameters only (Soft Reset)

If you want to keep all your User Programs & User Multis and only reset the Global Mode parameters, then select “Yes”.

User PROGRAMs	No changes. Nothing is reset
User MULTIs	No changes. Nothing is reset.
Global Mode	ALL GLOBAL PARAMETERS ARE RESET TO THE ORIGINAL FACTORY DEFAULTS.

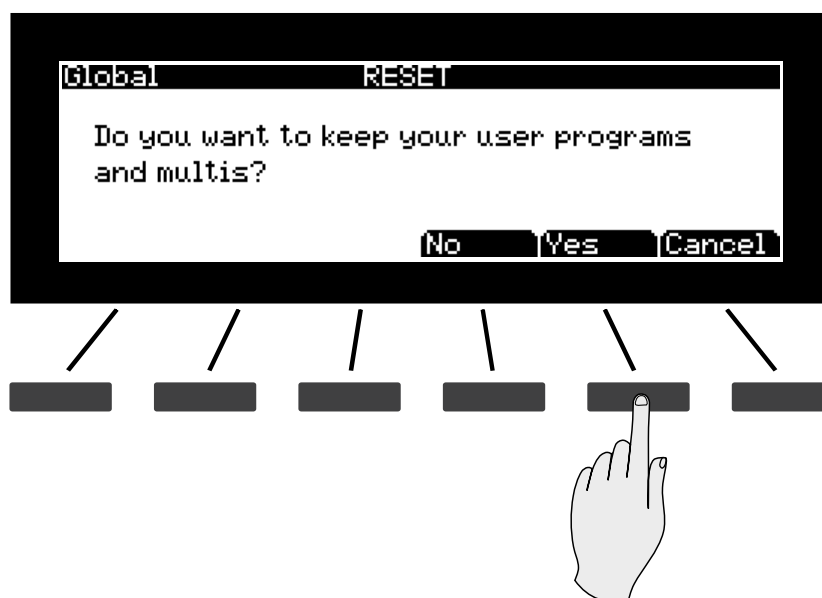

Press CANCEL if you are unsure, or do not wish to proceed with the reset.

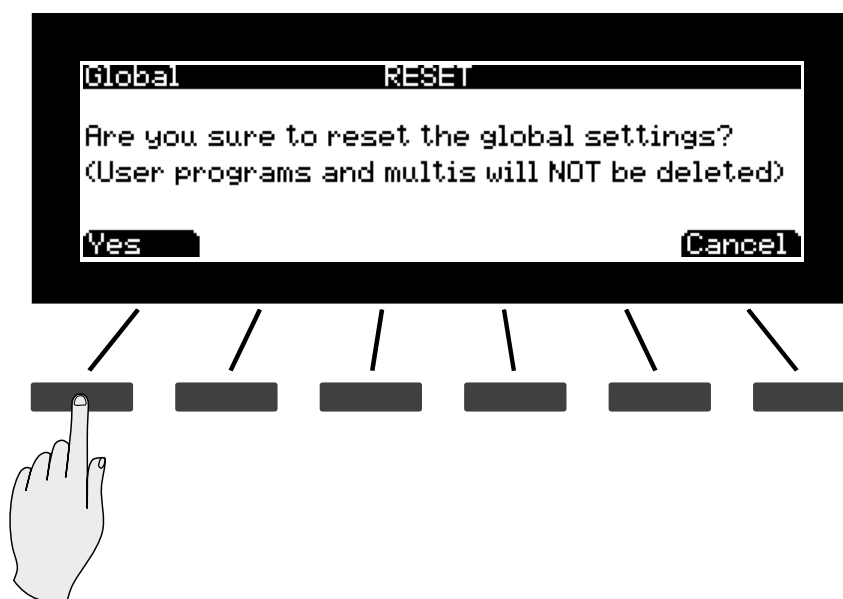

Press "Yes" if you wish to perform the global settings reset.

Press "Cancel" if you are unsure, or do not wish to proceed with the reset.

Reset Artis to its factory state (Hard Reset)

If you want to want to restore the Artis back to its factory state then select “No”.

The factory state means all your existing User Programs & User Multis will be permanently erased. This can not be undone. Make sure you have used the Store function to backup all of the Programs and Multis that you wish to keep. All Global Mode parameters, will be reset to default settings.



CAUTION: Performing the following reset, will result in **ALL** User Programs & User Multis will be erased. Global parameters are returned to there default state. This can not be reversed. Kurzweil recommends that you save (STORE) all your Programs and Multis that you wish to keep before performing any type of reset on Artis.

Selecting “No”:

User PROGRAMs	ALL USER PROGRAMS ARE DELETED.
User MULTIs	ALL USER MULTIS ARE DELETED.
Global Mode	ALL GLOBAL PARAMETERS ARE RESET TO THE ORIGINAL FACTORY DEFAULTS.

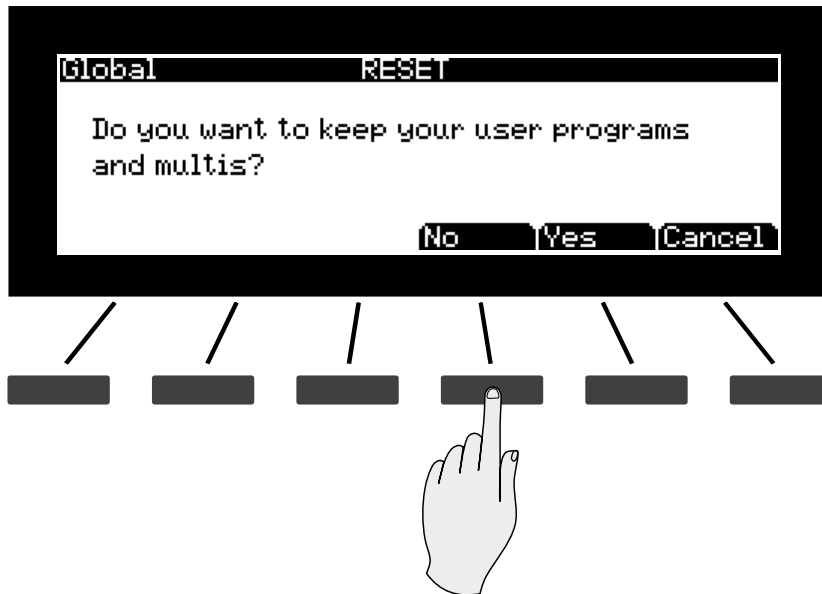

Press “Cancel” if you are unsure, or do not wish to proceed with the reset.

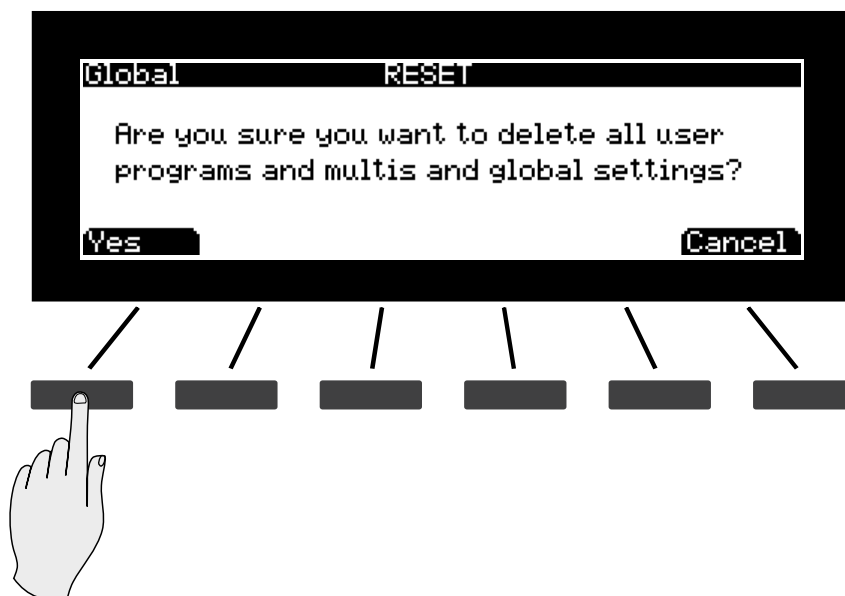

Press "Yes" if you wish to erase all the User Programs & User Multis and Global parameters.

Press "Cancel" if you are unsure, or do not wish to proceed with the reset.

Chapter 10

System Mode



CAUTION: DO NOT ATTEMPT TO MAKE ANY CHANGES IN SYSTEM MODE UNTIL YOU HAVE READ AND FULLY UNDERSTOOD THIS CHAPTER

This chapter will help you familiarize yourself with the functions of System Mode.

System Mode allows you manage and upgrade the OS software of your Artis as well as perform diagnostic tests of the instrument's various internal systems and processes. Note that the functions that you have access to in System Mode govern the operation of your Artis, so only use System Mode when you must perform essential maintenance tasks.

To enter System Mode, follow these steps:

1. Power off your Artis.
2. Press and the hold the **ENTER** button, and power on the unit. Make sure to keep holding the **ENTER** button until the display shows the following:
3. Release the **ENTER** button—at this point, you are in System Mode.

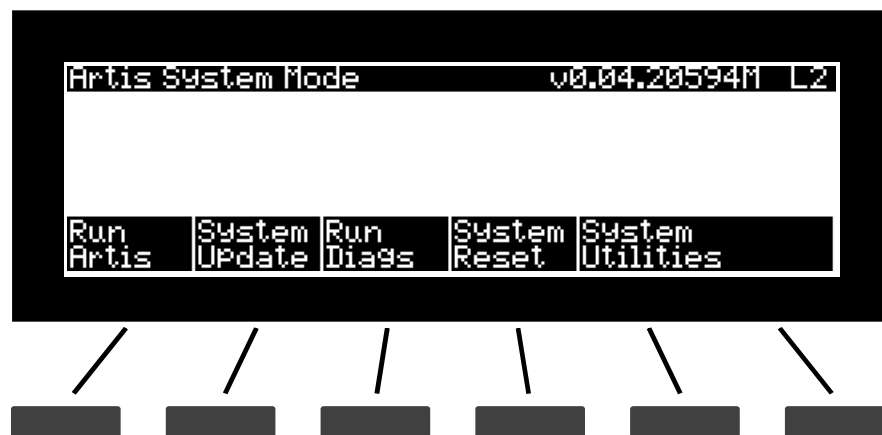

System Mode

Run Artis

Run Artis

This is the first System Mode menu item.

Pressing the “**Run Artis**” soft button will load the OS and the Artis will start up as if you just switched on the unit.

If the Artis operating system fails to load up, you will see an error message with an error code.

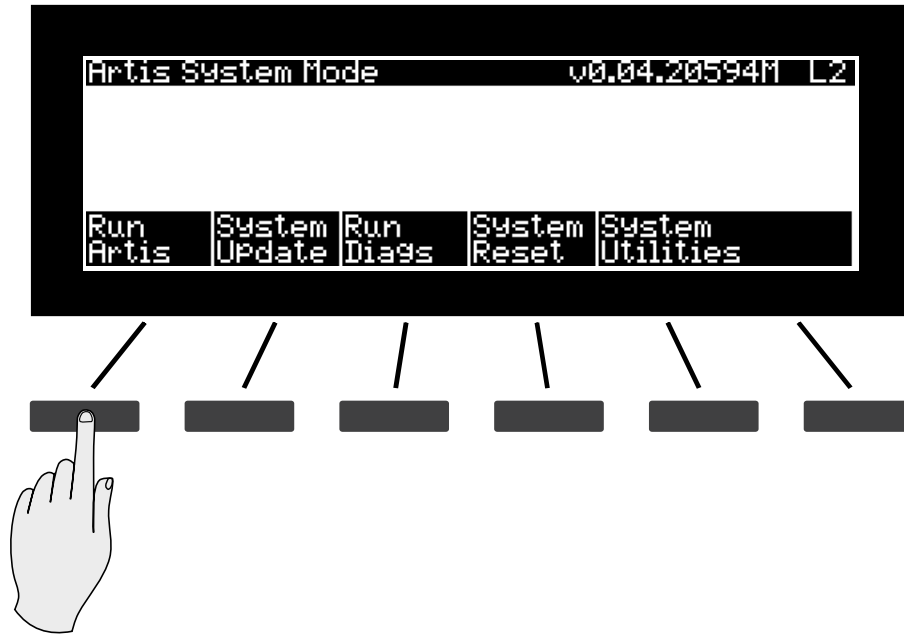

System Update

System Update allows you to keep your Artis running the latest available OS (Operating System), which you can download from the Kurzweil website.

The file that is used to install a new OS version with sounds is combined into one file called a KUF file (.KUF).

A USB flash drive or computer (using a USB cable) can be used to perform the System Update.

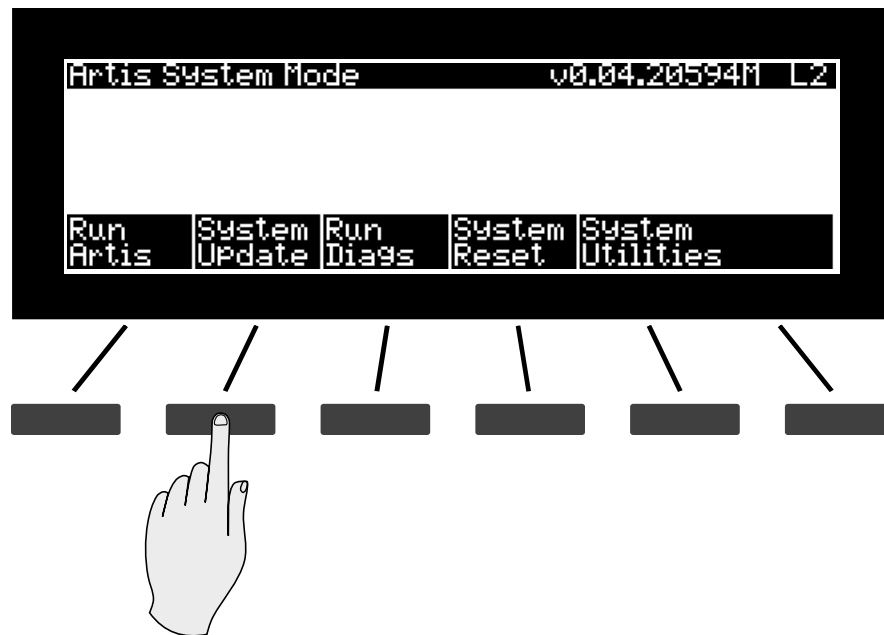

Install using a USB flash drive

1. Download the System Update file from the Kurzweil website or another reliable source and save it in a known folder or directory on your flash drive.

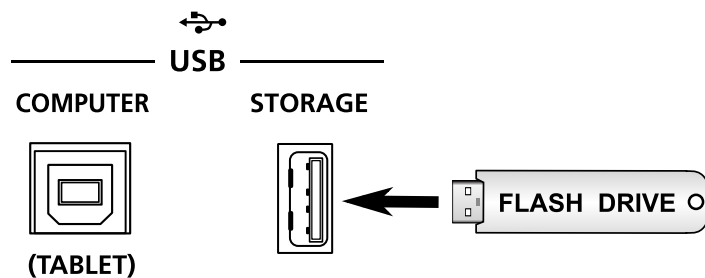

2. Connect the flash drive to the USB STORAGE slot of Artis (powered off).
3. Follow the instructions specified on page 10-1 to enter System Mode.

System Mode

System Update

4. In System Mode, select System Update.

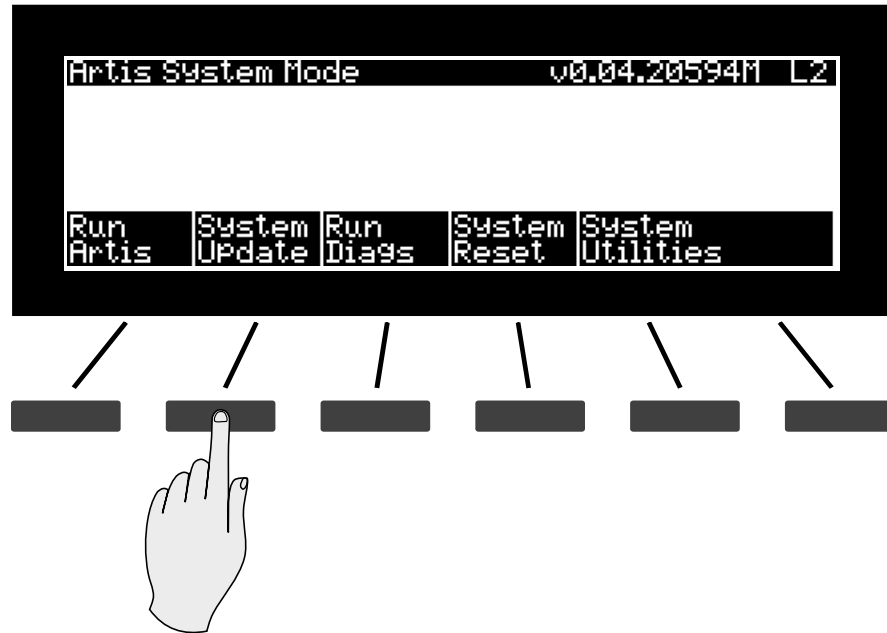

5. Select USB Device as the storage type.

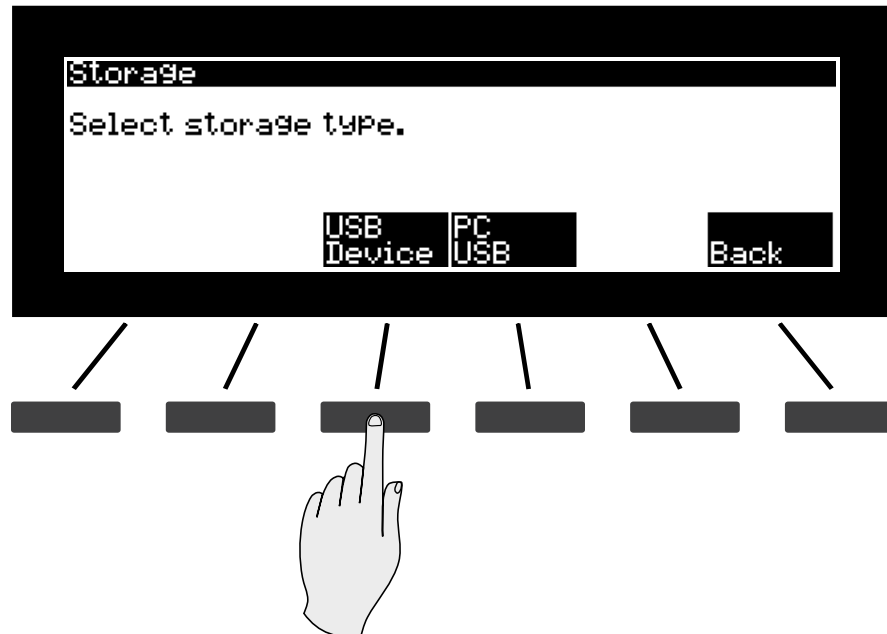

6. If the system was able to read the USB flash drive that was plugged in, it will display a list of files and folders as shown above. You can use the Chan Up/Down or Alpha wheel to move up and down the list. Select the UP soft button if you want to go up to the parent directory level. If the KUF file is selected, select the OK button.

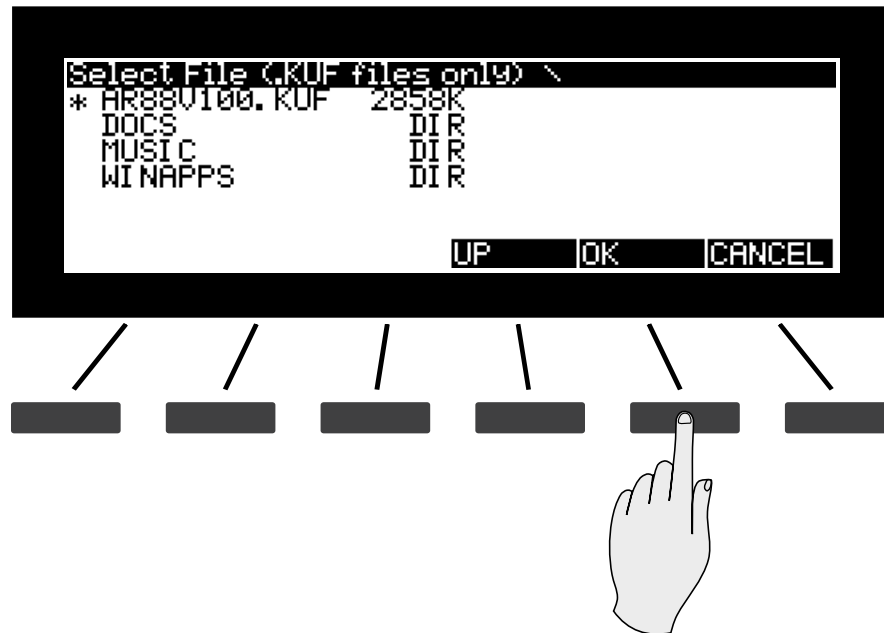

You will see a progress bar indicating the progress. If update was successful you will see a confirmation message. If there was a failure you will see a self-explanatory failure message (with error code) to indicate the failure.

Install using a computer/tablet

1. Download the System Update file from the Kurzweil website or another reliable source and save it in a known folder or directory on your flash drive.
2. Connect the Artis (powered off) to the computer/tablet with the USB cable provided into the USB COMPUTER slot.
3. Follow the instructions specified on page 10-1 to enter System Mode.
4. In System Mode, select System Update.

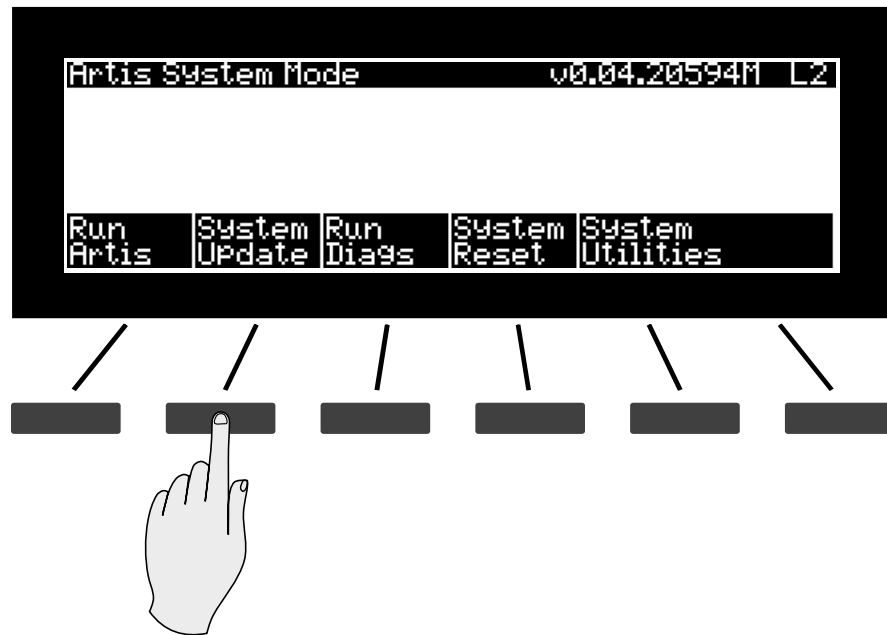

5. Select PC USB as the storage type.

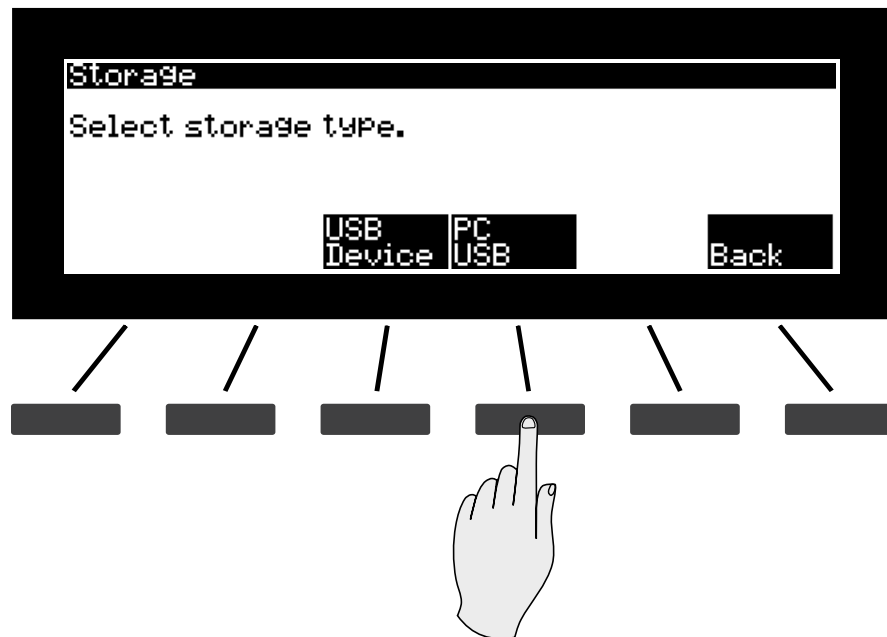

6. If the Artis cannot detect a connection to the computer it will display the message below.

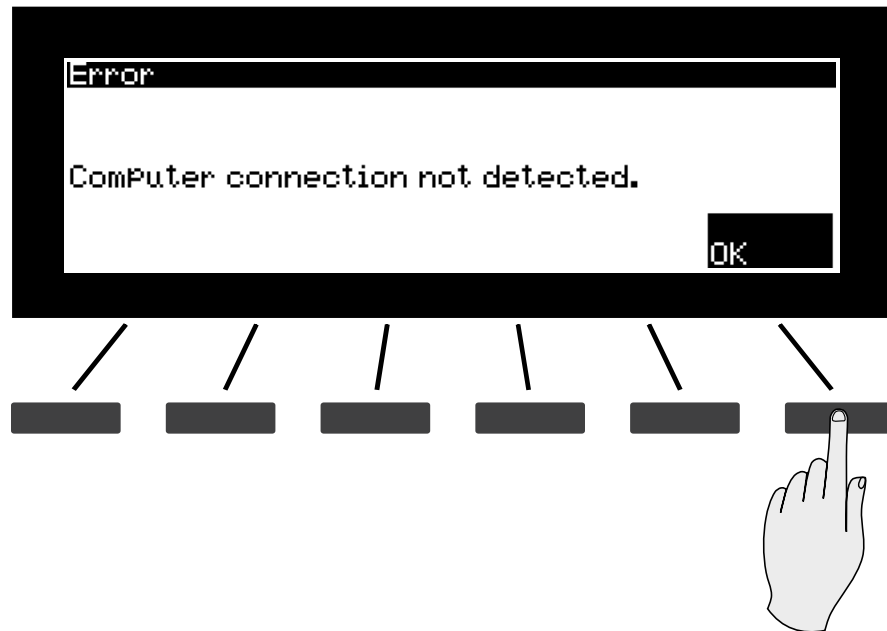

7. If the connection was detected, you will be prompted with the above message. Copy the KUF file to the virtual drive that appears on the PC and press OK.

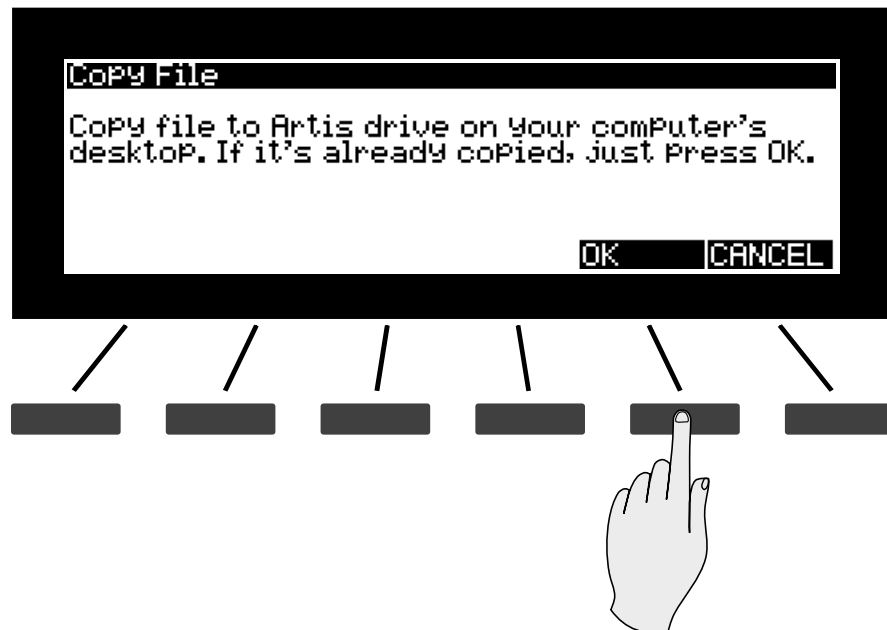

8. Select the file from the list displayed on the next screen and Press OK.

You will see a progress bar indicating the progress. If update was successful you will see a confirmation message. If there was a failure you will see a self-explanatory failure message (with error code) to indicate the failure.

Run Diagnostics

You will most likely not need to use the Run Diagnostics operations in normal cases.

These operations are mostly used at the factory and service centers by technicians for troubleshooting hardware problems. But, in some cases you might be required to run these diagnostics for troubleshooting and diagnosing symptoms. In these cases, following the direction of Kurzweil Technical Support.

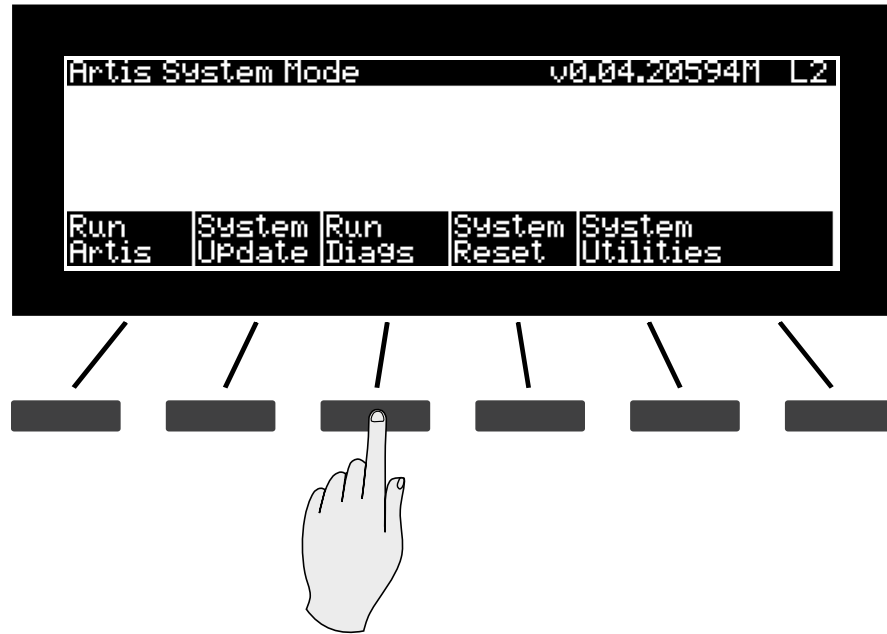

System Reset



CAUTION: THIS OPERATION ERASES ALL USER PROGRAMS & MULTIS.

System Reset will restore the Artis back to a Factory State. In addition to all user Programs and Multis being deleted, Global Mode settings will be restored to factory defaults.

To clear all user Programs/Multis and restore the factory default state, select the System Reset menu option.

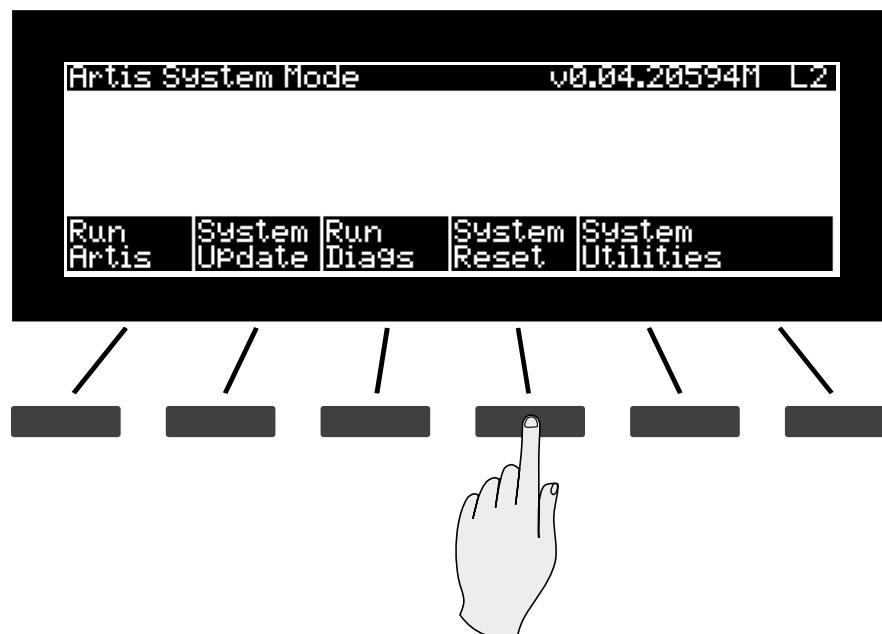

The Artis will now ask the question “This will delete all user objects. Are you sure?”

If you are not sure what you are about to do, select CANCEL. This will exit the System Reset process and take you back to the System Mode menu.

If you select OK you are now erasing all the user objects (Programs & Multis) in the Artis and restoring the instrument back to a Factory State.

System Mode

System Reset

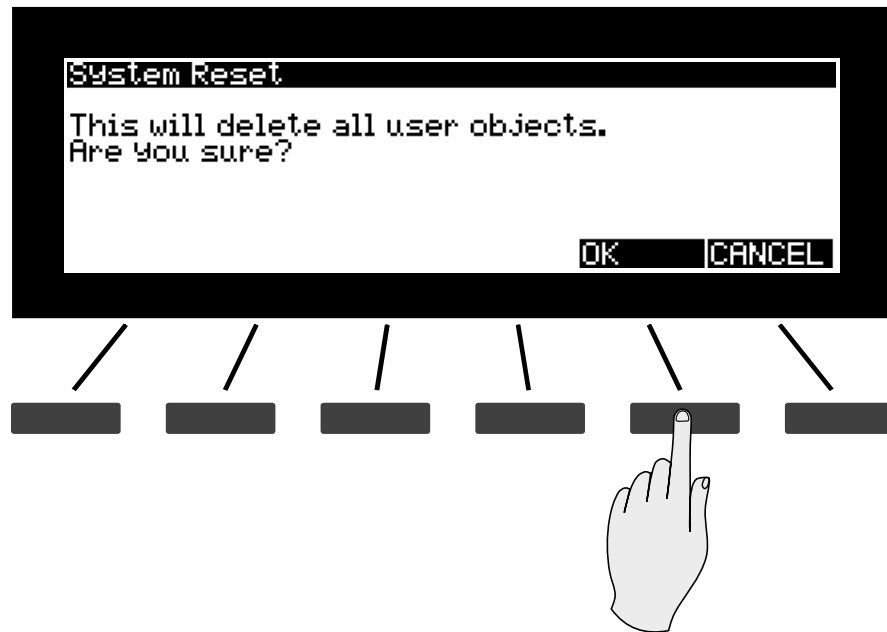

If you have completed the System Reset, select OK.

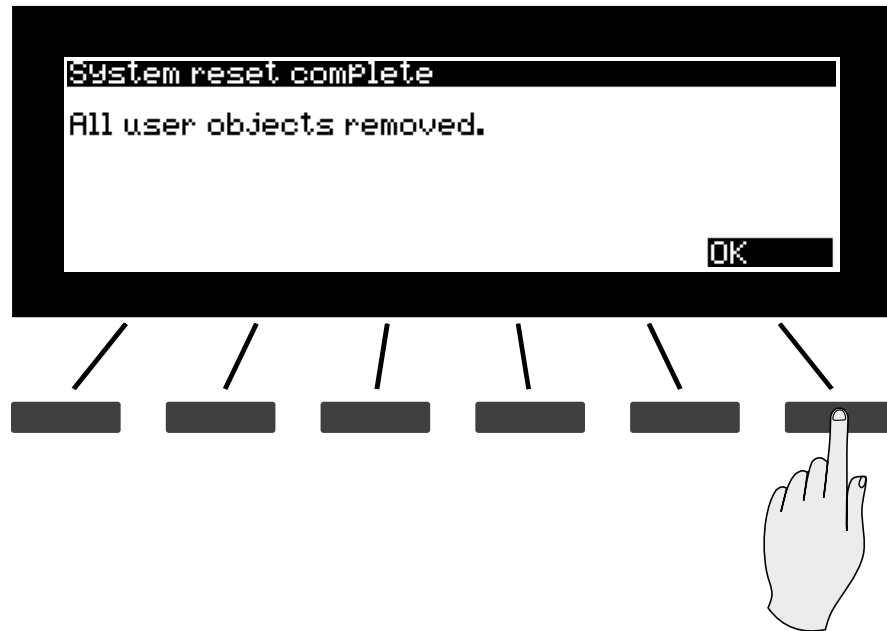

Remember to save your User Programs and User Multis to your computer following the instructions in the Store Page on page 9-17. Once deleted, these files are completely removed from the Artis and there is no way to retrieve them.

System Utilities

System Utilities contains various utilities for system administration.

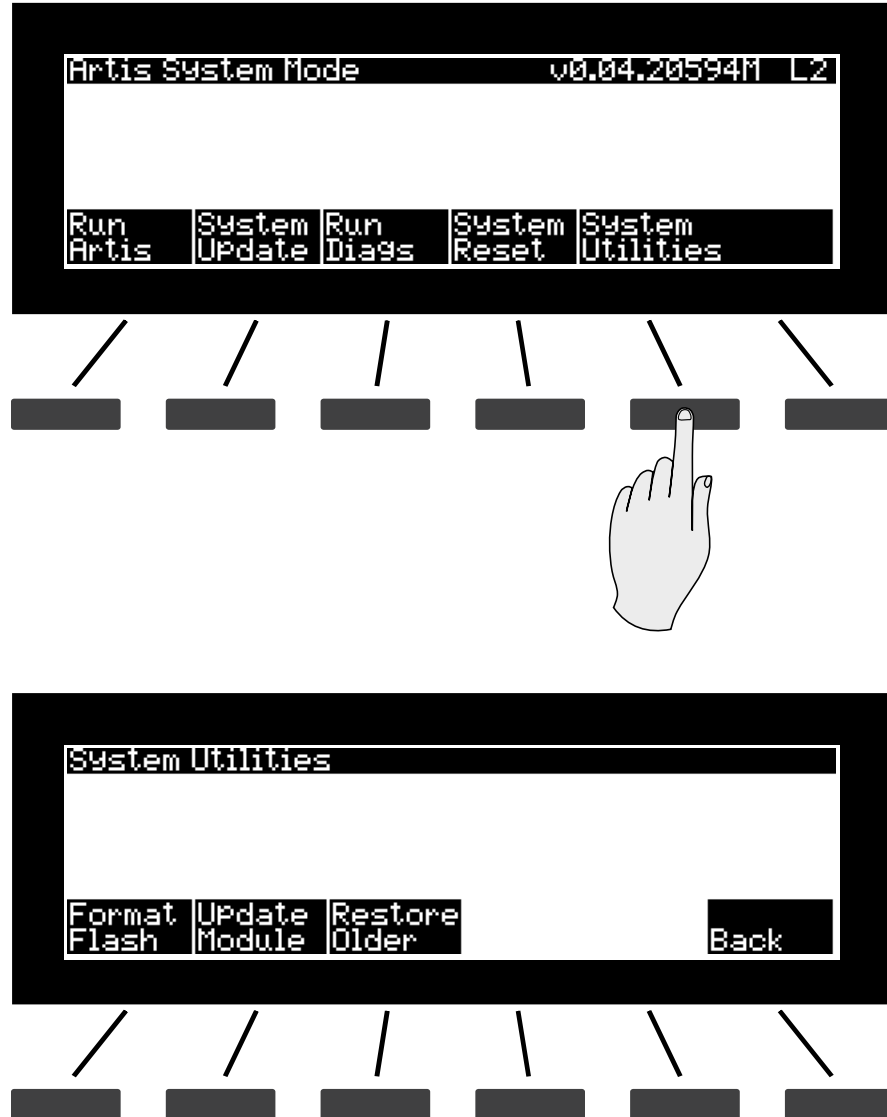

Select “Back” if you wish to exit and return back to the System Mode menu.

Format Flash



CAUTION: THIS OPERATION ERASES THE OPERATING SYSTEM, ALL FACTORY OBJECTS AND ALL USER OBJECTS.

Performing this operation will format the Artis's system flash memory and erase the OS software as well as *all* Objects. Do not do this unless you think it is necessary in order to improve the performance of your Artis. Should you decide to do so, be sure to back up all of your files and software. After you do this, System Mode will still be available, so you can run updates and get your Artis up-and-running again. After a Format the unit will come up in System Mode by default.

To perform a Format, follow these steps:

1. Follow the instructions specified on page 10-1 to enter System Mode.
2. Select System Utilities.

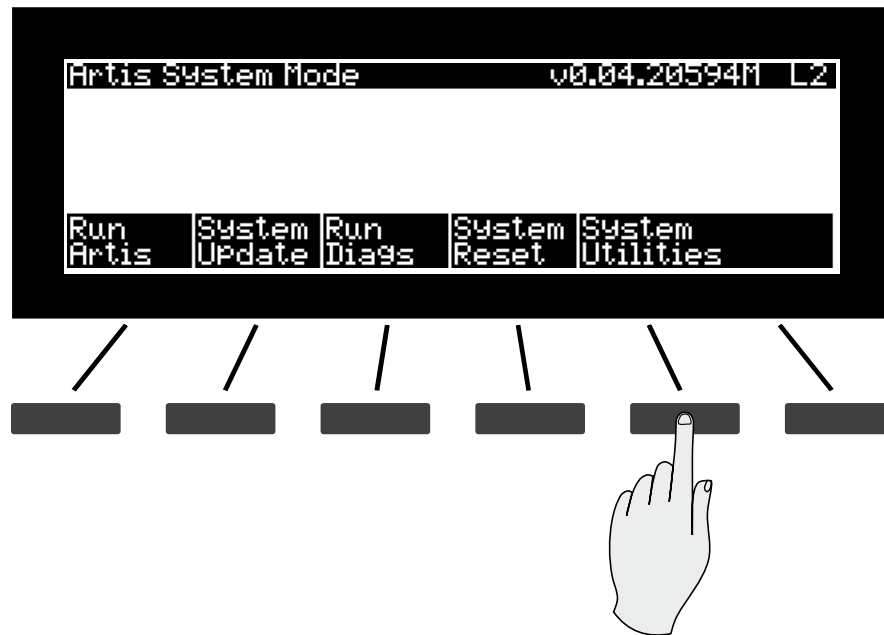

3. Press Format Flash.

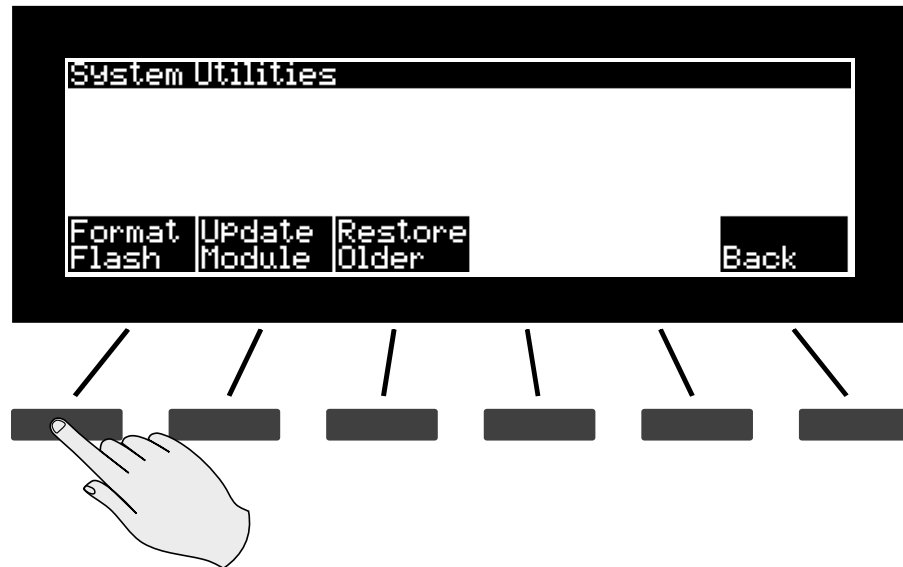

4. The next screen wants to make sure that formatting the flash and deleting everything is really what you want to do. Select OK to format the internal flash memory. Select CANCEL if you do not wish to proceed.

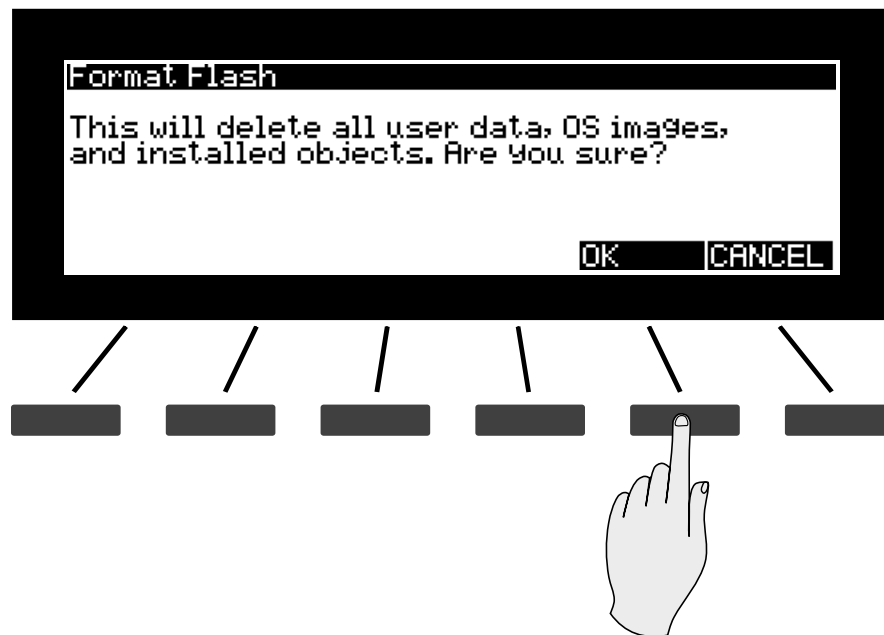

System Mode

System Utilities

5. When formatting of the internal flash memory is completed, the display will show the message "Done formatting flash.". Press OK.

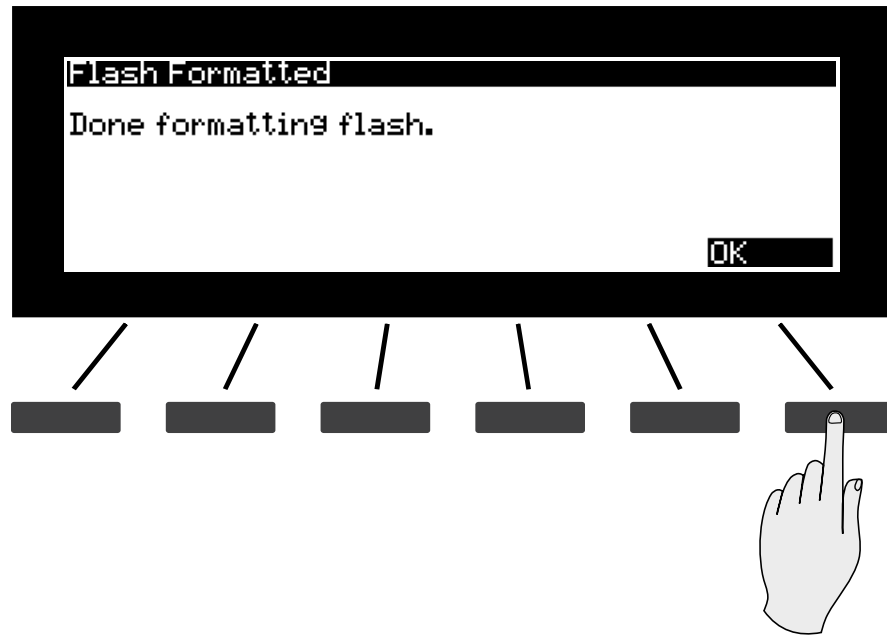

Update Module

This option allows the installation of individual files. You may be guided by Kurzweil Technical Support to use this option if needed.

Restore Older

If you have updated the Artis but wish to return to the earlier version, you can use the Restore Older option.

Chapter 11

Troubleshooting

Maintenance

Aside from normal care in handling and use, your Artis requires no regular maintenance. Clean with a soft cloth dampened with water. Never use abrasives or solvents as they may damage the unit's paint, markings and display lens. There are no batteries inside to replace—ever. Instead of volatile SRAM used in most other instruments, your Artis uses nonvolatile Flash Memory for storage, which retains information without power.

Common Problems

Below is a list of the most commonly encountered problems and diagnoses for each.

Power Problems

This is the normal power-up sequence:

1. The display backlight turns on.
2. “Loading...” appears on the display for a few seconds.
3. The Artis enters Program Mode with Program 1 or the Category Default Program for the Piano1 category selected.

If nothing at all happens when you turn the power switch on, check if one of the following might be the issue:

The power cable is not plugged securely into the wall outlet.

Plug the power cable securely into the wall outlet.

The power cable is not plugged securely into the Artis power jack.

Plug the power cable securely into the Artis power jack.

Troubleshooting

Common Problems

The wall outlet, power strip, or extension cord is defective or damaged.

Use a different wall outlet, power strip, or extension cord.

If there's evidence of the unit receiving power, but operation is abnormal, check if one of the following might be the issue:

The wall outlet voltage is below 90 volts due to overload.

Try a different outlet on a different circuit.

Powers up, Display is Blank

The Display is blank or difficult to read.

Slowly turn the Display contrast knob (located above the Alpha Wheel) to adjust the Display.

Audio Problems



CAUTION: Do not trouble shoot audio problems using headphones. Additionally, always be aware of the volume levels on the Artis and on the connected audio system or mixer.



NOTE: When diagnosing audio problems, set the Artis to play its Demo Song rather than intermittently pressing keys. This will prevent any unexpectedly loud volume changes.

If there is no sound from your Artis, check if one of the following might be the issue:

The volume slider is turned down.

Slowly push the volume slider up.

The volume control on the audio system or mixer is turned down.

Slowly turn the volume control up.

The signal source selection on the audio system or mixer is incorrect.

Set the volume of the audio or mixer to the lowest level, select the correct signal source, and then slowly turn up the volume.

The audio cables are not securely plugged into the Artis, audio system, or mixer.

Set the volume of the audio or mixer to the lowest level, securely plug in the audio cables on both ends, and then slowly turn up the volume.

The Destination parameter stops MIDI Data

Change the Global Destination parameter to Local + MIDI (see page 9-8)

The audio cable is of an incorrect type.

Obtain and securely connect an audio cable of the correct type. The Artis accepts both balanced (TRS) and unbalanced (TS) 1/4-inch audio cables.

If you can hear sound but it is low or distorted, check if one of the following might be the issue:

The audio cables are not securely plugged into the Artis, audio system, or mixer.

Set the volume of the audio system or mixer to the lowest level, securely plug in the audio cables on both ends, and then slowly turn up the volume.

A received MIDI volume message has specified a low volume.

Set the volume of the audio system or mixer to the lowest level. Disconnect all MIDI cables, set the Destination parameter in Global Mode to Local or MIDI+Local, and reset the volume level on the Artis, by pressing Panic (see page 3-17). Finally, slowly turn up the volume level of the audio system or mixer.

The current Multi has another controller assigned to volume, and it is turned down.

Select a different Multi. Or change the problematic controller setting by editing the Multi in Multi Edit Mode.

The input to the audio system is set for low impedance instead of high impedance.

Set the volume of the audio or mixer to the lowest level, change the impedance setting, and then slowly turn up the volume of the audio system or mixer.

The input trim to the audio system or mixer is set too low.

Slowly turn up the trim.

MIDI Problems

If you are experiencing problems sending MIDI to an external module, check if one of the following might be the issue:

The MIDI cable is not securely plugged in at both ends.

Securely plug in the MIDI cable at both ends.

The MIDI connections are wrong.

To send MIDI, plug the MIDI cable into the Artis' MIDI Out port and into the module's MIDI In port.

The MIDI cable is defective.

Obtain and securely connect a new MIDI cable.

The MIDI transmit channel does not match that of the receiving device.

Change the channel on either the Artis or on the device such that the channels match.

If there are problems with the internal sound module receiving MIDI from an external device like a computer sequencer, check if one of the following might be the issue:

The MIDI transmit channel of transmitting device does not match that of the receiving Program or Zone on the Artis.

Change the channel on either the Artis or on the computer such that the channels match.

The MIDI cable is not securely plugged in at both ends.

Securely plug in the MIDI cable at both ends.

The MIDI connections are wrong.

To receive MIDI, plug the MIDI cable into the Artis' MIDI In port and into the module's MIDI Out port.

Pedal Problems

Before you consult this section, be sure to read *Connecting Pedals* page 2-7.

Switch Pedal Problems

If you are having problems with connecting or using a switch pedal, check if one of the following might be the issue:

- Sustain or Sostenuto is stuck “on”. Be sure the pedal is plugged in before switching on the power. Turn power off, then on, if necessary.
- The pedal is acting backwards (“on” when up instead of down). Power cycle the unit making sure to NOT press on the pedal during startup.
- A dual switch pedal is not working correctly, see *Connecting a Dual Switch Pedal* on page 2-8. A dual switch pedal must be wired as shown below. Any other wiring pattern will not work correctly.

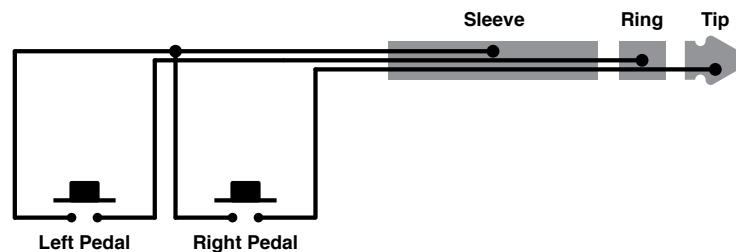

Continuous Control and Half Damper Pedal Problems

The continuous control pedal must be wired to a single stereo 1/4-inch plug as follows:

- Wiper to Tip
- Top end of resistance element to Ring
- Bottom end of resistance element to Sleeve

These connections are shown schematically below:

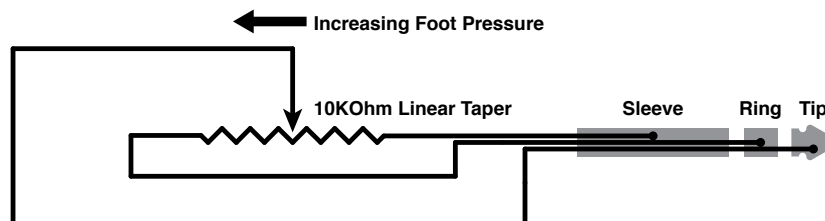

Use the correct impedance, taper, and range

Troubleshooting

If None of the Above...

For best results, use a Kurzweil CC-1 continuous control pedal, available from your dealer. The CC-1 meets all of the requirements described above at an economical price. A continuous control pedal should have an impedance between 5,000 and 100,000 ohms. An impedance less than 5,000 may overload the reference voltage source in the Artis and interfere with operation of other controls like the Master Volume slider or the other sliders. An impedance more than 100,000 may result in electrically noisy operation, which may cause your Artis to send MIDI controller messages constantly.

The taper of the control should be linear for easy, predictable control. Pedals designed for volume control typically have an exponential (or anti log) taper, which results in most of their range being concentrated in the upper half of pedal's path of travel.

Pedals may have a control range that is less than 100%. Make sure that when the pedal is in the fully down position, its impedance is 0, and when it is in the fully up position, the impedance is at its maximum rating.

If None of the Above...

If your problem is not covered above, or none of the suggestions seems to work, first check back and review the relevant sections of this manual. Many difficulties are just programming problems caused by settings of Multi parameters. If you want to be sure that all of the factory defaults are in place, see Restoring Factory Defaults on page 11-6.

Also be sure to check out Kurzweil's website for additional Artis information that may have been published since this manual was written: www.kurzweil.com.

If you still have problems, contact Kurzweil support in your country or at www.kurzweil.com/support/. You may also find unofficial help at some of the internet communities listed at www.kurzweil.com/community/.

Service Centers

Contact the nearest Young Chang office Kurzweil service representative. See page iv in the front matter of this manual for contact information.

Restoring Factory Defaults

There are two ways to restore factory defaults, both of which delete all User Programs and User Multis. The first method is described on page 9-20. The second is described in System Reset on page 10-9.



CAUTION: Restoring factory defaults cannot be undone. Back up your files before doing so by following the procedure on page 9-17

Diagnostics

You will most likely not need to use the System Mode diagnostic operations in normal cases. These operations are mostly used at the factory and service centers by engineers for troubleshooting hardware problems. But, in some cases you might be required to run these diagnostics for troubleshooting and diagnosing symptoms. In these cases, follow the direction of an authorized Kurzweil technician.

Troubleshooting

If None of the Above...

Appendix A

MIDI Implementation

Function		Transmitted	Recognized	Remarks
Basic Channel	Default	1	1	Memorized
	Changed	1–16	1–16	
Mode	Default	Mode 3	Mode 3	Use Multi-track mode (see FX Select (FXSel) on page 9-4 for multitimbral applications)
	Messages			
	Altered			
Note Number			0–127	
	True Voice	0–127	0–127	
Velocity	Note ON	O	O	
	Note OFF	O	O	
Aftertouch	Keys	X	O	
	Channels	X	O	
Pitch Bender		O	O	
Control Change		0–31 32–63 (LSB) 64–127	0–31 32–63 (LSB) 64–127	Controller assignments are programmable
Program Change		0 to 2,097,151	0–511	Standard and custom formats
	True #	0–127	0–127	
System Exclusive		O	O	
System Common	Song Pos.	X	X	
	Song Sel.	X	X	
	Tune	X	X	
System Real Time	Clock	X	X	
	Messages	X	X	
Aux Messages	Local Control	O	O	
	All Notes Off	O	O	
	Active Sense	X	X	
	Reset	X	X	
Notes	Manufacturer's ID = 07 Device ID: default = 0; programmable 0–127			

Mode 1: Omni On, Poly
Mode 3: Omni Off, Poly

Mode 2: Omni On, Mono
Mode 4: Omni Off, Mono

O = Yes
X = No

Appendix B

Physical Specifications¹

Keyboard:	<u>Artis</u> : 88-key, fully-weighted hammer-action (Fatar TP/100) with velocity sensitive adjustable keys. <u>ArtisZ</u> : 76-key, semi-weighted action (Fatar TP/8) with velocity sensitive adjustable keys.	
Display:	240x64 pixel monochrome LCD with front-panel contrast adjust.	
Polyphony:	128 Voice Polyphony, dynamically allocated.	
Multitimbral:	16 parts (one per MIDI channel).	
Quick Split / Layer:	Easy access with adjustable relative volume.	
Programs:	256 Factory plus 256 User Programs.	
Multis:	256 Factory Multis, plus 256 User Multi locations with 4 programmable zones for splits and layers.	
Effects:	Dozens of complex effect chains, incorporated into programs. Not editable, excepting Aux Override.	
Controllers:	<ul style="list-style-type: none"> • Pitch wheel • Modulation wheel • Volume Slider • 9 front panel sliders • 9 KB3 Control Switches / Control / Zone Mute Switches • 1 Variation switch • 4 Master EQ Knobs • 1 EQ On/Off Switch • 2 switch pedal inputs, each supporting single, dual switch pedals, or single half damper pedals • 1 continuous control pedal input • 2 Transpose buttons 	
Analog Outputs:	<ul style="list-style-type: none"> • Two 1/4" balanced TRS analog (24-bit DACs) • +21DBu maximum output • 400Ω balanced source impedance • 24-bit D-to-A converters 	
Headphones:	1 front panel 1/4" headphone output 8 V _{RMS} maximum output, 47Ω source impedance	
MIDI:	IN, OUT	
USB:	Complete MIDI functionality over USB User Program / Multi file transfer to/from PC / Mac / Tablet/ USB Flash Drives. Operating System updates from PC / Mac / USB Flash Drive	
Height:	<u>Artis</u> : 5.5" (14 cm)	<u>Artis7</u> : 4.8" (12.4 cm)
Depth:	<u>Artis</u> : 15.5" (39.5 cm)	<u>Artis7</u> : 14.2" (36 cm)
Length:	<u>Artis</u> : 54.5" (138.5 cm)	<u>Artis7</u> : 42.4" (107.7 cm)
Weight:	<u>Artis</u> : 46 lbs (21 kg)	<u>Artis7</u> : 27.7 lbs (12.6 kg)
Power:	<u>Artis</u> : Internal Switched Power Supply 90-265 V AC 50/60 Hz <u>ArtisZ</u> : Internal Switched Power Supply 100-240 V AC 50/60 Hz	

¹ Specifications subject to change without notice

Physical Specifications

Appendix C

Programs

PIANO 1

ID	PROGRAM
1	Concert Piano
2	Rock Piano
3	Recital Piano
4	Bright Classical
5	Parlor Piano
6	Jazz Piano
7	Stadium Pop Pno
8	Radio Pop Pno

ID	PROGRAM
9	Power Pop Piano
10	Big Rock Piano
11	Upright Piano
12	Blues Piano
13	Classic Rock Pno
14	Modern Rock Pno
15	NOLA Piano
16	Stage Piano

PIANO 2

ID	PROGRAM
17	R&B Keys
18	HipHop Piano
19	EDM Piano
20	Soul Piano
21	Pub Piano
22	Indie Piano
23	Seventies Piano
24	Piano & Pad

ID	PROGRAM
25	Piano & Choir
26	Piano & Harp
27	Film Piano
28	Ambient Piano
29	Dark & Distant
30	Delay Piano
31	Mono Piano
32	Triple Strike

ELECTRIC PIANO 1

ID	PROGRAM
33	Stevie's EP
34	Duke's Dyno EP
35	Beaten in EP
36	Fagen Phaser
37	Hotrod Dyno EP
38	Sweet Loretta EP
39	EP/WahSW
40	XfadBelltoneEP

ID	PROGRAM
41	WoodstockClunker
42	Stage Mix EP
43	Super EP
44	Darkside/Wah
45	What'd I SayEP
46	ACL EP
47	BrightDynamicEP2
48	DeepFuzz EP

ELECTRIC PIANO 2

ID	PROGRAM
49	FM EP 1
50	FM EP 2
51	Elec Grand Stack
52	Rich EP+Pad
53	Crisp and Soft
54	Tight Bright FM
55	Gabriel's Melt
56	CP80 Enhanced

ID	PROGRAM
57	VideoKilledRadio
58	UK Pop CP70
59	MistyMountain EP
60	No Quarter Pnt
61	Black Friday
62	Sly Ballad
63	RoyalKingWakeman
64	Spaced Out Bach

ORGAN 1

ID	PROGRAM
65	Classic B3
66	Funky Perc
67	Soul Perc
68	First Three
69	PerfectStrangers
70	'70s Drawbars
71	Progbars
72	Ezra II

ID	PROGRAM
73	Ezra's Burner
74	Classic Traffic
75	Mr Smith
76	HotTubeGospel
77	VASTBars1-3,8&9
78	Doors Vox
79	Animals Vox
80	Combo Organ

ORGAN 2

ID	PROGRAM
81	All Stops
82	AllStops AllVox
83	Pipe Stops
84	Chapel Organ
85	Pipes & Voices
86	16' Open Flute
87	16' Ped Reed
88	16' Reed A

ID	PROGRAM
89	16' Viol
90	LateNighter
91	Testify
92	The Ninth Bar
93	Blues Harmonica
94	ParisCmboAccordn
95	MellowAccordion
96	BrazilAccordion

CLAVINET

ID	PROGRAM
97	Black Cow Clav
98	Crisp Clav
99	RealSupasticious
100	Joe's Clav
101	Rufus/Marley WAH
102	Hiya Ground sw
103	TrampledUnder D6
104	HeartbreakerWAH

ID	PROGRAM
105	SailinShoes Clav
106	Shoobie Model C
107	Stevie Fuzz
108	StopMakingSense
109	Mutron+Synth sw
110	EvilWomanDeepFuz
111	Harpsichord
112	StBaroque Harpsi

BRASS/WINDS

ID	PROGRAM
113	Session Hornz
114	High-End Horns
115	Split SectionSW
116	Mancini Brass
117	Mostly Saxes
118	GB Hornz+Syn
119	Super-8 Brass
120	Brass Fanfare

ID	PROGRAM
121	Low Orch Brass
122	Bassoon/Oboe
123	Lead Trumpet
124	Solo Trombone
125	Solo Alto Sax
126	Solo Tenor Sax
127	Flute/Clarinet
128	Solo Bari Sax

STRINGS

ID	PROGRAM
129	Adagio Strings
130	Big LA Strings
131	Fast Strings
132	Slow String Trem
133	AdagioTutti 8ves
134	Adagio Octaves
135	NashvilleStrings
136	Poltergeist Pad

ID	PROGRAM
137	Full Pizzicato
138	Winds & Strings
139	Gothic Climax
140	Yesesis Tron Str
141	3Way Split Mltrn
142	Solo Violin fast
143	Solo Cello fast
144	Solo Harp

VOICES

ID	PROGRAM
145	Mixed Choir
146	Manhattan Voices
147	Choir Complete
148	NYC in LA
149	Crystal Voices
150	Cathedral Vox
151	Silent Sorrow
152	Swept Tron Voice

ID	PROGRAM
153	Slo Orch Chorus
154	Aaah Vocals
155	Jazzy Ballad Vox
156	Bright Syn Vox
157	AntiqueAhhChorus
158	Vox Orgel
159	Aaahlicious
160	PolyTechnobreath

SYNTHS

ID	PROGRAM
161	Super Saw
162	Classic SynBrass
163	80's Heaven
164	80's Lead Synth
165	PolySynth Stack
166	Chillwave Chords
167	Dark Wobbles
168	Classic Saws

ID	PROGRAM
169	Big Old Jupiter
170	Punchy Synth
171	Touch Trance
172	Minipulse 4Pole
173	FrankensteinWah
174	Grudge Lead
175	Square Bell
176	Daft Lead

PADS

ID	PROGRAM
177	Film Score Pad
178	MW S&H Filt
179	Runner Pad
180	Majestic Pad
181	So Lush Pad
182	Undercurrents
183	Fairlight Pad
184	Phase Shimmer

ID	PROGRAM
185	Evolving Pad
186	Lush Pad
187	Deeper Water
188	Lush Rhythm Pad
189	Cosmic Sus Pedal
190	Slo Syn Orch
191	Add A Pad 1
192	Add a Pad 2

GUITAR

ID	PROGRAM
193	Rich 'Caster
194	Rich Les
195	SuperStudioCast
196	PhasePickLes
197	TimeWarpCaster
198	Kinda Krunchy
199	Brown Sound
200	RedHot/StudioStr

ID	PROGRAM
201	SuperflyWahCast
202	Jack the Ripper
203	Raw & Bleedin'
204	Boutique Six Str
205	Boutique 12 Str
206	3Str Mandolin
207	3Str Banjo
208	Dulciliere

BASS

ID	PROGRAM
209	P-Bass
210	Motown Bass
211	E-Bass
212	Flea/Bootsy
213	Jaco Fretless
214	Noise Bass
215	AC Buzzer Bass
216	Woodhouse Bass

ID	PROGRAM
217	Aggro OctoBass
218	KneeDeepMinimoog
219	Squeeze Mini
220	Iceman Bass
221	ANGRYBass
222	Big Synth Bass
223	The Way It Is
224	Bass Pedal

DRUMS

ID	PROGRAM
225	Kit 1 Open Rock
226	Kit 2 J Geils
227	Kit 3 West Boxy
228	Kit 4 SquashRock
229	Kit 5 Beatbox101
230	Kit 6 Full Room
231	Kit 7 Brush
232	Kit 8 CopperRing

ID	PROGRAM
233	Kit 9 Big Buzz
234	Kit 10 DeadRockr
235	Kit 11 Low Rock
236	Kit 12 GaddsLair
237	Kit 13 KirkeeB
238	Kit 14 ModernRok
239	Kit 15 Drum&Bass
240	Kit 16 Skrlx

PERCUSSION

ID	PROGRAM
241	Celeste
242	Chimes/Glock
243	Real Vibes
244	Stereo Marimba
245	Xylophone
246	XHarmonicStlDrum
247	Carillon
248	Natural Perc

ID	PROGRAM
249	Percussionist
250	Basic Orch Perc
251	PERC Carnival
252	VRT Accessory
253	VRT BongoConga
254	VRT TalkingDrum
255	Vocal Percussion
256	Orch Timpani

Appendix D

KB3 Programs

Introducing KB3 Programs

There's nothing quite like the sound of a classic tone wheel organ, especially when played through a rotating speaker system. We've done extensive testing and analysis with several tone wheel organs, and created our own models to emulate the unique tone wheel sound. We even took into account the way that older organs start to sound different (and arguably better) as their capacitors begin to leak—and we included a parameter that varies the amount of grunge (leakage) in your sound.

First Some History

Countless blues, jazz, and rock recordings have centered around the distinctive sound created by classic tone wheel organs played through rotating speaker systems. Not only is the sound great, but it's supremely versatile, since the player can control timbre in real-time by adjusting drawbars that add or remove harmonics from the fundamental tone. Other cool sound-shaping tools include a percussive emphasis that can be added to each note and the capability to change speaker rotation speed. Many people, in fact, feel that the tone wheel organ was the first popular synthesizer. And although these organs haven't been made for years, they are still sought after, restored, and lugged about by legions of dedicated keyboard players. This despite archaic electronics, inscrutable wiring, and an unwieldy heft that tops 400 pounds.

Duplicating the sound and flexibility of these organs – without the nasty side effects – is the goal of KB3 Mode.

Drawbars

The drawbars on a tone wheel organ emulate pipes of different lengths on a pipe organ. In either case, they are controlled by changing the positions of a number of “stops”. As the organist pulls out or pushes in these stops, he adds or reduces harmonics. Whether it’s pipes or drawbars, though, the stops work like this: pull one out to add more of an overtone; push it in to reduce the volume of the overtone.

The stops on the most popular tone wheel organs are: 16’, 5 $\frac{1}{3}$ ’, 8’, 4’, 2 $\frac{2}{3}$ ’, 2’, 1 $\frac{3}{5}$ ’, 1 $\frac{1}{3}$ ’ and 1’. Note that they are still measured in feet, a carryover from pipe organ days. The 16’ and 5 $\frac{1}{3}$ ’ stops are considered the subharmonic group, while the third stop, 8’, produces the fundamental of a tone, and stops 4-9 produce harmonics above the fundamental. By making use of different combinations of these harmonics, a rich sort of additive synthesis is possible. Best of all, you can make radical changes to the tone dynamically as you play.

The nine sliders of the Artis are set to control the drawbars, as listed in blue below the sliders. Pulling the slider towards the keyboard increases the amount of the drawbar that is heard.

KB3 Mode Buttons

The nine buttons above the sliders on the Artis have special capabilities in KB3 Mode that are listed in blue, below the Multi Zone Mute Buttons and Programmable Switches. These are:

Brake

Brake starts and stops the rotary speaker effect. This effect is not immediate, instead the rotary speaker effect gradually slows down and speeds up, in a similar way that a real rotary speaker reacts.

Chorus/Vibrato

On/Off

This parameter turns the chorus or vibrato effect on and off.

Chor/Vib

This parameter determines which modulation effect is used. The choice is Vibrato or Chorus

Chorus/Vibrato Depth

This parameter determines how much of the effect is applied to the KB3 sounds. There are two levels of both Chorus and Vibrato available, depending on the setting for the Chor/Vib button.

Percussion

Percussion is a characteristic feature of tone wheel organs. It's especially useful while soloing, since percussion adds an extra plink (actually an extra tone at a defined harmonic) to the attack of individual notes. When you play more than one note simultaneously, only the first note you play will trigger the envelope of the percussion tone, though notes played shortly afterwards will also be affected by this envelope. When you play chords, all of the notes played simultaneously will get the percussive effect (provided percussion hasn't already been triggered.)

Percussion On/Off

This is where you turn the percussion effect on or off. Percussion is created by a decaying envelope applied to one of the nine drawbars (usually the 4th drawbar for the low pitch and the 5th drawbar for high pitch. The highest drawbar is normally stolen to generate the percussion sound). The percussion effect is "single-triggered", which means that once it's triggered, it won't trigger again until all keys go up.

The KB3 engine in the Artis is capable of generating the Percussion effect without stealing any of the drawbars, and while not authentic, is occasionally used on Artis Programs.

Percussion Loud/Soft

This parameter switches between loud and soft percussion settings.

Percussion Decay F/S

This parameter switches between fast and slow percussion settings.

Percussion Pitch H/L

This parameter switches between high and low harmonic percussion settings.

KeyClick

The Key Click feature adds a decaying burst of pitched noise to the attack of notes. Unlike the percussion, the key click is "multi-triggered", which means that every new note will trigger it. The parameters on this page primarily control the decay, volume, and pitch of the key click.

This button controls whether the Keyclick parameter is switched on or off.

KB3 Programs

KB3 Mode Buttons

Variation

The variation button acts as a Fast/Slow switch for the rotary speaker effect. Using the Rotary S/F Override in the Global mode, any Pedal assigned to Sustain can also be used to control the rotary speed. If Rotary S/F Override is set to Off, then Pedals assigned to Sustain will act normally as a Sustain Pedal.

Index

A

Activating Zones 7-8, 7-10.
 Aftertouch. **See** Mono Pressure.
 Alphanumeric Entry 3-13, 8-9, 8-14, 8-19.
 Alpha Wheel 2-2, 3-11, 3-12, 6-2, 6-4, 6-5, 7-2, 7-3, 7-13, 8-4, 9-2.
 Assign 3-18, 6-12, 7-9, 8-3, 8-5.
 Enter + Controller 3-18, 8-5.
 Enter + Key 3-18, 6-12, 7-9, 8-5.
 Enter + Zone Button 8-3.
 Audio Cables 2-2, 2-5, 11-3.
 Audio In 3-9.
 Audio Jacks 2-5, 3-9.
 Audio Problems 11-2.
 Auto Power Off 9-3, 9-5, 9-6.
 Message 9-3, 9-5.
 Time 9-3, 9-5.
 Aux Effects 8-9, 8-23, 8-25.
 Channel 8-23.

B

Balanced Cable 2-2, 2-5.
 Bank
 Change 8-12, 8-14, 8-21, 9-9. **See** MIDI: Bank Changes.
 MIDI 4-2, 8-4, 8-6, 8-12, 8-13, 8-14, 8-21, 9-9.
 Mode 8-12, 8-14, 9-9.
 Select 9-8, 9-9.
 Bend 3-3, 8-21, A-1.
 Bend Range Down 3-3, 3-18, 8-5, 8-12, 8-14.
 Bend Range Up 3-3, 3-18, 8-5, 8-12, 8-14.
 Buttons
 Alphanumeric. **See** Alphanumeric Entry.
 Category 2-2, 3-13, 6-2, 6-5, 6-6, 6-19, 7-2, 7-4, 7-13.
 Double Press
 Demo 3-17.
 MIDI Program Change 3-16.
 Panic 3-17, 6-17, 11-3.
 Parameter Jump 3-15.
 Program Demo 3-16, 5-6, 6-2, 6-3.

Reset Transposition 3-15.
 Value Jump 3-11, 3-14, 3-15, 6-4, 6-11, 6-14, 7-3, 7-9, 7-11, 8-4, 8-6, 8-9, 9-2.
 Global 3-10.
 Multi 3-10, 5-2, 7-1, 8-2.
 Mute 3-18, 8-3, 8-5, D-2.
 Next 2-2, 3-11, 6-2, 6-4, 7-2, 7-3, 9-2, 9-3, 9-4, 9-9, 9-10, 9-11.
 Param/Channel 3-11, 3-12, 5-6, 6-16, 6-22, 8-4, 9-2.
 Previous 2-2, 2-13, 3-11, 6-2, 6-4, 6-6, 7-2, 7-3, 9-2, 9-3, 9-4, 9-9, 9-10, 9-11.
 Program 3-10, 5-1, 6-1.
 Soft 3-11, 5-3, 5-6, 5-7, 6-3.
 Value 3-11, 6-4, 7-3, 8-4.
 Zone 3-5, 7-6.

C

Category Buttons 2-13, 6-2, 6-3, 7-2.
 Category Default. **See** Default (Category).
 CC Jack 1-2, 2-4, 2-7, 2-9, 2-10, 3-5, 3-6, 8-16, 11-6.
 Channel 3-1, 3-10, 3-11, 3-12, 4-1, 4-2, 5-2, 6-1, 6-3, 6-16, 7-1, 7-6, 8-1, 8-6, 8-7, 8-19, 8-21, 8-23, 8-24, 9-2, 9-8, 9-10, 9-11, 11-4, A-1, B-1.
 Common Page 3-11, 8-2, 8-22.
 Common Parameters 8-1, 8-2, 8-4, 8-9.
 Connecting Audio 2-2, 2-5.
 Connecting MIDI 2-4, 2-11 to 2-12.
 Connecting Pedals 2-4, 2-7, 11-5.
 Continuous (Control) Pedals 2-7, 2-9, 3-5, 11-5, 11-6.
 Contrast Knob 3-11, 3-12, 11-2, B-1.
 Controller 1-1, 1-2, 2-3, 2-4, 2-11, 2-12, 2-13, 3-4, 3-6, 3-8, 3-10, 3-18, 4-2, 5-1, 5-2, 6-9, 6-10, 6-12, 6-13, 6-15, 6-17, 6-18, 6-22, 7-1, 7-6, 7-9, 7-11, 8-1, 8-4, 8-5, 8-8, 8-11, 8-12, 8-13, 8-14, 8-15, 8-16, 8-17, 8-18, 8-19, 8-20, 8-21, 8-22, 9-8, 9-9, 9-11, 9-13, 9-17, 11-3, 11-6, A-1.
 CTRLS Page 8-4, 8-15.

D

DataDec 9-3, 9-6.
 DataInc 8-18, 9-3, 9-6.
 Default (Category) 3-14, 6-1, 6-4, 6-6, 7-1, 7-2, 7-3, 7-4.
 Choosing 6-6, 7-4.
 Default (Power Up) 3-1.
 Deleting User Multis 7-16.

Index

Deleting User Programs 6-21.
Demo Function 3-17, 5-6.
Demo Song 3-16, 3-17, 5-6, 6-2.
Destination 8-7, 9-6, 9-8, 9-10, 11-3.
 Controller 8-4, 8-5, 8-15, 8-16, 8-17, 8-18, 8-19, 8-20.
 Local 8-6, 8-7, 8-8, 8-9, 8-12, 8-13, 8-21, 9-8, 11-3, A-1.
 MIDI 8-6, 8-7, 8-8, 9-8.
Diagnostics 10-8, 11-7.
Display
 Contrast Knob 3-12, 11-2, B-1.
 Problems 11-2.
Double Button Presses 3-14, 3-15, 3-16, 3-17, 6-4, 7-3, 8-4,
 8-6.
Dual Switch Pedal 2-4, 2-7, 2-8, 2-10, 11-5, B-1.

E

Edit Button 5-7, 8-2.
Editing Parameters 3-15, 3-18, 6-11, 6-14, 7-11, 8-1, 8-3,
 8-4, 8-5, 8-6, 8-7, 8-12, 8-16, 8-17, 8-23, 9-1, 9-2.
Effects 8-9, 8-23, 8-25, B-1.
 Aux 8-4, 8-9, 8-23, 8-25.
 Aux FX Channel 8-23.
 Aux Override B-1.
 Aux Send Level 8-6, 8-9, 8-25.
Enter + Zone 3-18, 8-5.
Entry Program Change. **See** Program Change: Entry.
Entry State 8-16, 8-19.
Entry Value 8-16, 8-22.
EQ. **See** Master EQ.
Exit State 8-16, 8-19.
Exit Value 8-16, 8-22.

F

Factory 1-2, 2-13, 3-1, 3-10, 4-3, 5-2, 6-1, 6-2, 6-3, 6-4, 6-5,
 7-1, 7-2, 7-12, 8-23, 9-1, 9-22, 10-8, 10-9, 11-6, 11-7,
 B-1.
Favorite Buttons 3-1, 6-1, 6-2, 6-7, 7-2, 7-5, 9-6.
FavoriteDec 9-3, 9-6.
FavoriteInc 9-3, 9-6.
Features 1-1, 3-1.
Feet (Rubber) 1-3, 2-1, D-2.
Files 9-16, 10-5, 10-10, 10-12, 10-15, 11-6.
 Delete All 10-9, 11-6.
 Load (Fill) 9-15, 9-16.
 Loading 3-10, 5-2, 8-12, 8-13, 8-19, 8-22, 8-24, 9-13,
 9-14, 9-15, 9-16, 9-18, 10-2.
 Load (Overwrite) 9-15, 9-16.
 Saving. **See** Store.
File Utilities 10-11.
Flash Drive. **See** USB Flash Drive.
Format System Flash Memory 10-12, 10-13.

Front Panel 2-2, 2-13, 3-2, 3-4, 3-10, 3-11, B-1.
Functions 5-3.
 Demo. **See** Demo Function.
 Layer. **See** Layer.
 MIDI Program Change 3-16, 5-4, 8-13.
 Program Demo. **See** Program Demo.
 Split 5-3. **See** Split: Function.
FX. **See** Effects.
FX Select 9-2, 9-4, A-1.

G

General MIDI
 Velocity Map 9-2, 9-4.
Getting Started 2-1.
Global Button 3-10.
Global Mode 2-8, 3-1, 3-5, 3-10, 3-11, 3-15, 4-3, 5-2, 6-16,
 9-1, 9-2, 9-8, 9-13, 9-17, 9-20, 9-22, 10-9, 11-3.
Global Parameters 5-2, 8-7, 9-1, 9-20, 9-22, 9-23.

H

Half Damper Pedal 2-7. **See** Pedal: Half Damper.
Hard Reset 3-10, 4-3, 5-2, 9-1, 9-22.
Headphones 2-2, 2-5, 2-6, B-1.
High Key 3-18, 8-5, 8-10.
High Velocity 8-11.

I

ID Numbers 3-11, 5-6, 6-3, 6-18, 6-19, 7-2, 7-12, 7-13,
 9-11, 9-15, 9-16.

K

K2600 Bank Mode 8-12, 8-14.
KB3 Mode 1-1, D-1, D-2.
 Channel 8-23, 8-24.
 Controls 3-3, 3-4, 3-5, 3-6, 3-14, 8-21, 9-7, B-1, D-2 to
 D-4.
 KB3 LED 3-14.
Keyboard 1-2, 2-1, 2-2, 3-5, 4-1, 4-2, 5-2, 5-3, 6-10, 6-12,
 7-6, 7-7, 7-8, 7-9, 8-7, 8-11, 9-2, 9-8, 9-10, 9-11,
 9-12, B-1, D-1, D-2.
Key High. **See** High Key.
Key Low. **See** Low Key.
KEYS Page 8-4, 8-10.
Knob 3-7, 3-11, 3-12, 11-2.
KUF File 4-3, 10-3, 10-5, 10-7.

L

Layer 4-2.
 Function 4-2, 5-3, 5-4, 6-12, 6-13, 6-14, 6-15, 7-10, 7-11.
 Program 6-13, 6-14, 7-10, 7-11.

Transposition 6-14, 7-11.
 Volume 6-14, 7-11.
 LCD Display 3-8, 3-11, 5-3, 9-2, B-1.
 LED 3-5, 3-6, 3-7, 3-8, 3-10, 3-14, 6-1, 6-5, 6-6, 6-8, 6-9,
 6-18, 7-1, 7-4, 7-6, 7-7, 9-1.
 Load. **See also** Files: Loading.
 Errors 9-13, 9-14, 9-16.
 PC 2-13, 9-14, 9-15, 9-18, 10-6, 10-7, B-1.
 USB 1-3, 2-3, 2-13, 3-10, 9-5, 9-8, 9-9, 9-10, 9-11, 9-13,
 9-14, 9-16, 9-17, 9-18, 10-3, 10-5, 10-6, B-1.
 Local Keyboard Channel 9-8, 9-10, 9-11.
 Local Program 8-12, 8-13.
 Low Key 3-18, 8-5, 8-10.
 Low Velocity 8-11.

M

MAIN Page 8-4, 8-6.
 Maintenance 10-1, 11-1.
 Master EQ 3-1, 3-7, B-1.
 MIDI 1-1.
 Bank 5-5. **See** Bank: MIDI.
 Bank Change Messages 8-12, 8-13, 8-21.
 Channel 3-1, 3-10, 3-11, 3-15, 4-1, 4-2, 5-2, 6-1, 6-3, 6-16,
 8-6, 8-7, 8-23, 8-24, B-1. **See also** Channel.
 Channel Enable 6-16, 9-8, 9-10.
 Channel Transmit 3-11, 3-12, 6-16, 7-1, 7-6, 8-1, 8-7, 9-8,
 9-10, 9-11, 11-4.
 Connecting. **See** Connecting MIDI.
 Implementation Chart A-1.
 Page 8-12, 9-8.
 Ports 2-4, 2-11, 9-8.
 Problems 11-4.
 Program Change 3-16, 5-1, 5-4, 5-5, 8-12, 8-13, 8-14, 9-8,
 9-10, A-1.
 Program Parameter 8-6, 8-12, 8-13, 8-14.
 Mode 2-2, 3-7, 3-12, 3-13, 4-2, 5-1, 5-3.
 Buttons 2-2, 3-10, 5-1, 5-2, 6-1, 6-20, 7-1, 7-15, 8-2, 9-1,
 D-2.
 Global. **See** Global Mode.
 Multi 2-8, 2-13, 3-1, 3-4, 3-5, 3-8, 3-10, 3-11, 3-12, 3-13,
 3-15, 4-1, 5-2, 5-3, 5-4, 5-7, 6-10, 6-12, 6-13, 6-15,
 7-1 to 7-16, 8-7, 8-20, 8-26, 9-8, 9-9, 9-11.
 Multi Edit 3-8, 3-11, 3-15, 3-18, 5-7, 6-12, 6-13, 8-1, 8-2,
 8-3, 8-5, 9-11, 11-3.
 Program 2-2, 2-13, 3-1, 3-4, 3-5, 3-8, 3-10, 3-11, 3-14,
 3-15, 3-16, 5-1, 5-3, 5-4, 5-6, 6-1 to 6-22, 8-20, 8-23,
 11-1.
 System. **See** System Mode.
 Mod Wheel 1-2, 3-3, 3-6, 3-18, 4-1, 5-1, 6-8, 6-9, 6-22, 7-7,
 8-5, 8-15, 8-18, 8-19, 8-20, 9-7, 9-11.
 Mono 2-2, 2-5, A-1.
 Mono Pressure 4-2, 8-21, 9-3, 9-7, A-1.

Mono Switch Pedal. **See** SW1; **See** SW2.
 Multi Edit Mode 3-8, 3-11, 3-15, 3-18, 5-7, 6-10, 6-12, 6-13,
 6-15, 7-8, 7-9, 7-10, 7-11, 8-1, 8-2, 8-3, 8-5, 9-6,
 9-11, 11-3.
 Multis 2-13, 3-10, 3-13, 4-1, 5-2, 7-1 to 7-16.
 Deleting. **See** Deleting User Multis.
 Editing. **See** Multi Edit Mode.
 Favorites 7-5. **See also** Favorite Buttons.
 Parameters List. **See** Zone: Parameters.
 Saving 6-12, 6-15, 7-9, 7-11, 7-12.
 Zones. **See** Zone.
 Muting Zones 1-2, 2-4, 7-6.

N

Naming 6-3, 6-16, 6-18, 6-19, 7-2, 7-12, 7-14, 8-6.
 Navigation 3-2, 3-11.
 Note Map 8-11.
 Numeric Entry. **See** Alphanumeric Entry.

O

Objects 4-3.
 Deleting All 10-9, 11-6.
 Loading. **See** Files: Loading.
 Programs. **See** Program.

P

Pan 8-20.
 Entry 8-6, 8-9.
 Panic 3-17, 11-3. **See also** Buttons: Double Press: Panic.
 Param/Channel buttons 5-5.
 Param/Channel Buttons 3-15, 5-6. **See** Buttons: Param/
 Channel.
 Parameter 7-8, 7-9, 8-22.
 List 3-12, 8-20.
 Parameter Assignments 6-9, 8-20.
 PC 2-13, 10-6, 10-7, B-1.
 Pedal 1-2, 1-3, 2-4, 2-7, 2-8, 2-9, 2-10, 2-13, 3-1, 4-1, 5-1,
 6-22, 8-16, 8-18, 11-5, 11-6, B-1, C-5.
 Dual Switch 2-4, 2-7, 2-8, 11-5, B-1.
 Half Damper 2-4, 2-9, 11-5, B-1.
 Mode 9-6.
 Pedal Page 8-16.
 Pedal Switch Override 9-6.
 Switch 9-6.
 Switch Parameters 8-16.
 Pitch Wheel 1-2, 3-3, 3-18, 8-5, 8-14.
 Power ii, iii, 2-2 to 2-8, 3-1, 6-11, 6-14, 7-9, 7-11, 9-2, 9-5,
 9-6, 10-1, 11-1, 11-2, 11-5, B-1.
 Problems 11-1.
 Power Cable iii, 1-3, 2-2.
 Power Off. **See** Auto Power Off.

Index

Pressure. **See** Mono Pressure.
Program 2-2, 2-13, 3-10, 3-13, 4-1, 5-1, 6-1 to 6-22.
Favorites. **See** Favorite Buttons.
List C-1.
Mode 9-4, 9-10, 9-11. **See** Mode: Program.
Saving 6-18.
Selection 2-13, 6-2, 6-5.
Program Change. **See** MIDI: Program Change.
Difference 8-13.
Entry 8-12, 8-14.
Function. **See** Functions: MIDI Program Change.
Program Demo. **See** Functions: Program Demo.
PRSMW Page 8-4.

R

Real Time Control 3-4.
Rear Panel Connections 1-2, 2-3, 2-5, 2-7, 2-9.
Reset
Hard 3-10, 4-3.
Soft 4-3.
System 10-9, 10-10, 11-6.
Restore 10-15. **See also** Reset.
Rotary S/F Override D-4.
Rubber Feet. **See** Feet (Rubber).

S

Save. **See** Multis: Saving; **See** Program: Saving; **See** Store.
Button 3-8.
Selecting
Modes. **See** Mode: Buttons.
Objects. **See** Objects: Selecting.
SLIDER Page 8-16.
Sliders 1-2, 2-13, 3-4, 3-8, 4-1, 5-1, 6-9, 6-22, 8-19, 9-11,
11-6, B-1, D-2.
Soft Button. **See** Buttons: Soft.
Soft Pedal 8-21, 9-6.
Soft Reset 3-10, 4-3. **See also** Reset: Soft.
Software
Restore. **See** Restore.
Update. **See** System Update.
Sostenuto 1-2, 2-4, 2-7, 2-9, 2-10, 3-5, 8-21, 9-6, 11-5.
Specifications B-1.
Split 4-2.
Button 6-10, 7-8.
Function 4-2, 5-3, 6-10, 6-11, 6-12, 6-15, 7-8, 7-9.
Key 3-18, 6-12, 7-9.
Program 6-10, 6-11, 6-12, 7-8, 7-9.
Transposition 6-12, 7-9.
Volume 6-11, 7-9.
Store 9-17, 9-18, 9-20, 9-22.
Support 2-4, 2-8, 10-8, 10-15, 11-6.
Sustain 1-2, 2-4, 2-7, 2-9, 2-10, 3-5, 8-18, 8-21, 9-6, 11-5,

D-4.
SW1 1-2, 2-4, 2-7, 2-8, 2-9, 8-18.
SW2 1-2, 2-4, 2-8, 2-9, 8-18.
Switch 1-2, 2-7, 3-8, 8-18, D-2, D-3.
Switch Buttons 3-5, 3-18, 4-1, 5-1, 6-9, 8-5, 8-18.
SWITCHES Page 8-17.
Switch Pedal 1-2, 2-4, 2-7, 2-8, 2-9, 2-10, 3-5, 11-5, B-1.
See also Pedal.
System Mode 10-1, 10-2, 10-3, 10-4, 10-6, 10-9, 10-11, 10-12, 11-7.
System Update 1-3, 2-3, 4-3, 10-3, 10-4, 10-5, 10-6, 10-7,
10-12, B-1.

T

Tablet 1-3, 2-3, 2-12, 10-6, B-1.
Thumb Drive. **See** USB Flash Drive.
Transpose
Buttons 3-6, 6-8, 7-7, B-1.
Reset 3-6, 3-15, 6-8, 7-7.
Zones 7-7, 8-10.
Troubleshooting 10-8, 11-1, 11-7.
Tuning 3-6, 3-10, 6-8, 7-7, A-1.

U

Update 2-3.
Update Module 10-15.
USB Flash Drive 2-3, 9-13, 9-17, 9-18, 10-3, 10-5.
USB MIDI 9-5, 9-8, 9-10.
USB Port 2-3, 2-13, 8-7, 8-8, 8-19, 9-9, 9-10, 9-11, 9-13,
9-14, 9-17, 9-18.
User Multis
Deleting. **See** Deleting User Multis.
Saving. **See** Multis: Saving.
User Objects
Deleting all. **See** Files: Delete All.
User Programs
Deleting. **See** Deleting User Programs.
Saving. **See** Program: Saving.

V

Variation Button 3-6, 6-9, 8-17, 8-18, 8-20, B-1, D-4.
Velocity 3-1, 3-10, 8-10, 8-11, 8-22, A-1, B-1.
Velocity Maps 3-1.
Volume 1-2, 3-4, 6-11, 6-14, 7-9, 7-11, 8-6, 8-9, 8-18, 8-20,
11-6, B-1.
Slider 2-2.

Z

Zone 1-2, 2-7, 3-4, 3-5, 3-11, 3-18, 4-1, 5-2, 6-10, 6-12,
6-13, 6-15, 7-1, 7-6 to 7-11, 8-1 to 8-26, 9-6, 9-10,
9-11, 11-4, B-1, D-2.

Activating. **See** Activating Zones.
Changing 8-3.
Muting 1-2. **See** Muting Zones.
Parameters 8-6.
Status 8-6.

KURZWEIL

www.kurzweil.com