



KURZWEIL

Music Systems

KURZWEIL Co., Ltd.

178-353 Gajwa-dong, Seo-gu, Incheon, KOREA
Tel:82-32-580-1500 Fax:82-32-584-4863

AND Music Corporation

10107 South Tacoma Way, Suite A-3 Lakewood, WA 98499
Tel:(253)589-3580 Fax:(253)589-3585

KURZWEIL



KURZWEIL

Music Systems

RE-110

Digital Piano
Owner's Manual

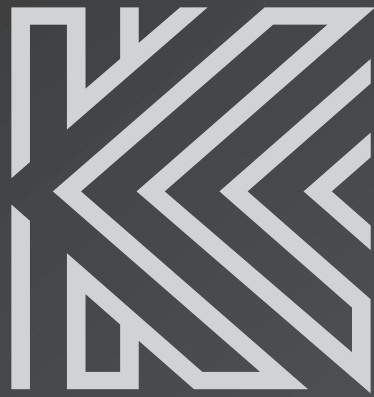

RE-110

Digital Piano Owner's Manual

Table of Contents

Important Safety & Installation		
Instructions	4	
Important Safety Instructions	5	
The Panel of the RE-110	6	
Introduction		
The Features of the RE-110	7	
Setting up the Instrument	8	
VOICE Button		
Main Voice	12	
Reverb & Chorus	13	
Demo Song	14	
SPLIT Button		
Split Point	15	
Lower Voice	15	
Upper Voice	15	
Lower Octave Shift	16	
Upper Octave Shift	16	
4-Hand Setup	16	
FUNCTION Button		
Touch	17	
Tune	17	
Transpose	18	
MIDI Receive and Transmit Channel	19	
Local Control	20	
Reset	20	
Pedals		
Sustain Pedal	21	
Sostenuto Pedal	21	
Soft Pedal	21	
MIDI		
MIDI Connection	22	
MIDI Channels	23	
Miscellaneous		
Headphone	24	
Audio In Jack	24	
Audio Out Jack	24	
MIDI Implementation Chart	25	
Appendix		
Specifications	26	
Quick Operation Guide	27	

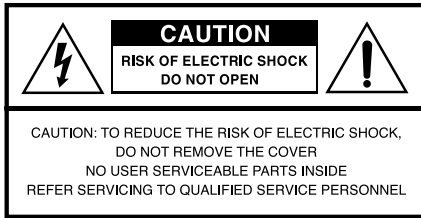

The lightning flash with the arrowhead symbol, within an equilateral triangle, is intended to alert the user to the presence of uninsulated "dangerous voltage" within the product's enclosure that may be of sufficient magnitude to constitute a risk of electric shock to persons.



The exclamation point within an equilateral triangle is intended to alert the user to the presence of important operating and maintenance (servicing) instructions in the literature accompanying the product.

IMPORTANT SAFETY & INSTALLATION INSTRUCTIONS

INSTRUCTIONS PERTAINING TO THE RISK OF FIRE, ELECTRIC SHOCK, OR INJURY TO PERSONS

WARNING : When using electric products, basic precautions should always be followed, including the following:

1. Read all of the Safety and Installation Instructions and Explanation of Graphic Symbols before using the product.
2. Do not use this product near water-for example, near a bathtub, washbowl, kitchen sink, in a wet basement, or near a swimming pool, or the like.
3. This product should only be used with a stand or cart that is recommended by the manufacturer.
4. This product, either alone or in combination with an amplifier and speakers or headphones, may be capable of producing sound levels that could cause permanent hearing loss. Do not operate for a long period of time at a high volume level or at a level that is uncomfortable. If you experience any hearing loss or ringing in the ears, you should consult an audiologist.
5. The product should be located so that its location or position does not interfere with its proper ventilation.
6. This product should be located away from heat sources such as radiators, heat registers, or other products that produce heat.
7. This product should be connected to a power supply only of the type described in the operating instructions or as marked on the product.
8. This product may be equipped with a polarized line plug (one blade wider than the other). This is a safety feature. If you are unable to insert the plug into the outlet, contact an electrician to replace your obsolete outlet. Do not defeat the safety purpose of the plug.
9. The power supply cord of the product should be unplugged from the outlet when left unused for a long period of time. When unplugging the power supply cord, do not pull on the cord, but grasp it by the plug.
10. Care should be taken so that objects do not fall and liquids are not spilled into the enclosure through openings.
11. The product should be serviced by qualified service personnel when:
 - A. The power supply cord or the plug has been damaged;
 - B. Objects have fallen, or liquid has been spilled into the product;
 - C. The product has been exposed to rain;
 - D. The product does not appear to be operating normally or exhibits a marked change in performance;
 - E. The product has been dropped, or the enclosure damaged.
12. Do not attempt to service the product beyond that described in the user maintenance instructions. All other servicing should be referred to qualified service personnel.
13. **WARNING :** Do not place objects on the product's power supply cord, or place the product in a position where anyone could trip over, walk on, or roll anything over cords of any type. Do not allow the product to rest on or be installed over cords of any type. Improper installations of this type create the possibility of a fire hazard and/or personal injury.

RADIO AND TELEVISION INTERFERENCE

WARNING : Changes or modifications to this instrument not expressly approved by KURZWEIL could void your authority to operate the instrument.

IMPORTANT : When connecting this product to accessories and/or other equipment use only high quality shielded cables.

NOTE : This instrument has been tested and found to comply with the limits for a Class B digital device, pursuant to Part 15 of the FCC Rules. These limits are designed to provide reasonable protection against harmful interference in a residential installation. This instrument generates, uses, and can radiate radio frequency energy and, if not installed and used in accordance with the instructions, may cause harmful interference to radio communications. However, there is no guarantee that interference will not occur in a particular installation. If this instrument does cause harmful interference to radio or television reception, which can be determined by turning the instrument off and on, the user is encouraged to try to correct the interference by one or more of the following measures:

- Reorient or relocate the receiving antenna.
- Increase the separation between the instrument and the receiver.
- Connect the instrument into an outlet on a circuit other than the one to which the receiver is connected.
- If necessary consult your dealer or an experienced radio/television technician for additional suggestions.

NOTICE

This apparatus does not exceed the Class B limits for radio noise emissions from digital apparatus set out in the Radio Interference Regulations of the Canadian Department of Communications.

AVIS

Le présent appareil numérique n'émet pas de bruits radioélectriques dépassant les limites applicables aux appareils numériques de la class B prescrites dans le Règlement sur le brouillage radioélectrique édicté par le ministère des Communications du Canada.

SAVE THESE INSTRUCTIONS

IMPORTANT SAFETY INSTRUCTIONS

1. Read these instructions.
2. Keep these instructions.
3. Heed all warnings.
4. Follow all instructions.
5. Do not use this apparatus near water.
6. Clean only with dry cloth.
7. Do not block any of the ventilation openings. Install in accordance with the manufacturer's instructions.
8. Do not install near any heat sources such as radiators, heat registers, stoves, or other apparatus (including amplifiers) that produce heat.
9. Do not defeat the safety purpose of the polarized or grounding-type plug. A polarized plug has two blades with one wider than the other. A grounding type plug has two blades and a third grounding prong. The wide blade or the third prong are provided for your safety. If the provided plug does not fit into your outlet, consult an electrician for replacement of the obsolete outlet.
10. Protect the power cord from being walked on or pinched, particularly at plugs, convenience receptacles, and the point where they exit from the apparatus.



11. Only use attachments / accessories specified by the manufacturer.
12. Use only with a cart, stand, tripod, bracket, or table specified by the manufacturer, or sold with the apparatus. When a cart is used, use caution when moving the cart / apparatus combination to avoid injury from tip-over.
13. Unplug this apparatus during lightning storms or when unused for long periods of time.
14. Refer all servicing to qualified service personnel. Servicing is required when the apparatus has been damaged in any way, such as power-supply cord or plug is damaged, liquid has been spilled or objects have fallen into the apparatus, the apparatus has been exposed to rain or moisture, does not operate normally, or has been dropped.
15. Allow adequate ventilation for the power adapter. Do not hide it under a carpet or behind a curtain or place it in an enclosed space where heat buildup can occur.

WARNING : To reduce the risk of fire or electric shock, do not expose this apparatus to rain or moisture. Do not expose this equipment to dripping or splashing and ensure that no objects filled with liquids, such as vases, are placed on the equipment.

To completely disconnect this equipment from the AC Mains, disconnect the power supply cord plug from the AC receptacle.

To reduce the danger of explosion if the lithium battery is incorrectly replaced, replace only with the same or equivalent type.

KURZWEIL

Music Systems



The Panel of the RE-110

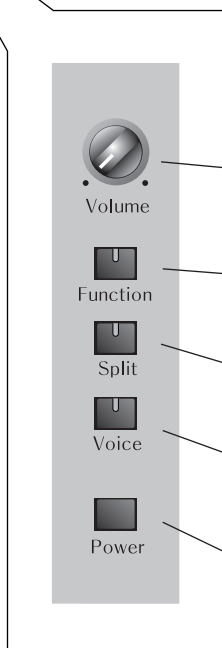
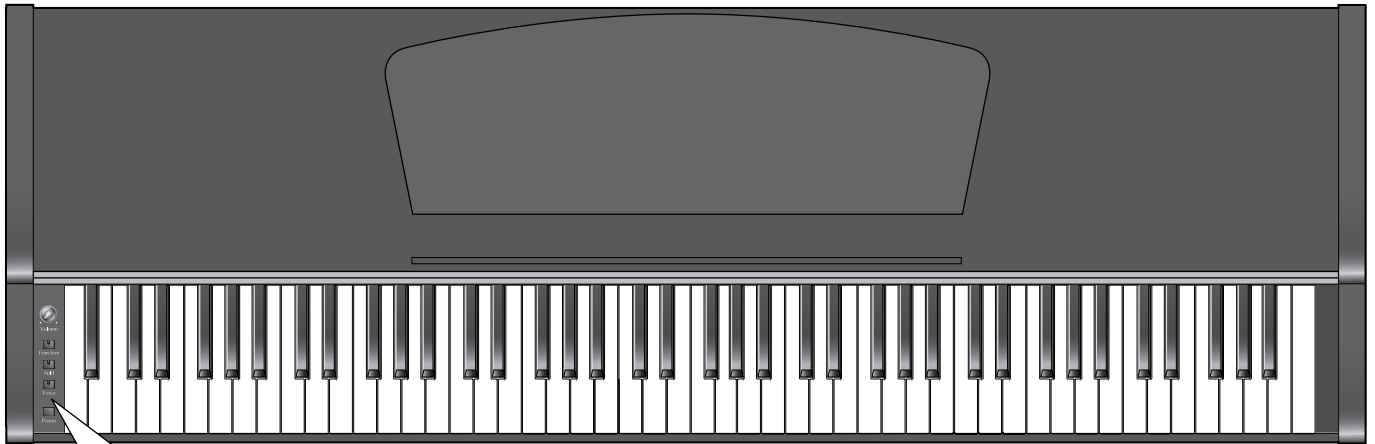
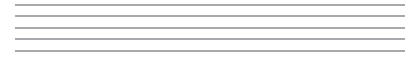

- ① Volume**
Adjust the volume level using this control
- ② Function**
Modify parameters of Touch, Tune, Transpose and MIDI channel
- ③ Split**
Divide the keyboard into two different sounds
- ④ Voice**
Select voices from 10 primary sounds and more, select various reverb effects
- ⑤ Power**
Turn the power On or Off





Introduction

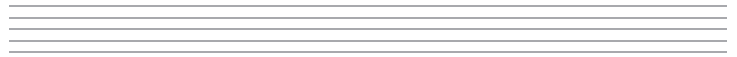

Welcome to the world of the KURZWEIL RE-110 Digital Piano.

The RE-110 gives you easy access to KURZWEIL's high-quality sound technology. Authentic digital representations of musical instrument sounds are the starting points. The RE-110 reproduces the finest details of the original sounds; you'll even hear differences in tone as you play from bass to treble and from soft and loud, just as in the original instruments.

The Feature of the RE-110

- 88 Notes, Hammer type keys
- 3 Pedals
- 5 Different levels of keyboard sensitivity
- 32 Preset voices
- Transpose, Tune
- 4 Reverbs, 1 Chorus effect
- Split keyboard mode
- 5 Demo songs
- Line In/Out
- MIDI In/Out
- 2 Headphone jacks
- 25 Watt Stereo sound system



Setting up the Instrument



Check that all of the following items are present.

Item	No.	Item	No.
① Keyboard	1EA	⑦ Screws for Side Panel and Keyboard	4EA
② Side Panel (Left)	1EA	⑧ Screws for Side Panel and Pedal Box	4EA
③ Side Panel (Right)	1EA	⑨ Screws for Rear Panel	2EA
④ Pedal Box	1EA	⑩ Screws for Rear Panel and pedal Box	4EA
⑤ Rear Panel	1EA	⑪ Cable Clamp	1EA
⑥ Headphone Hanger	1EA		

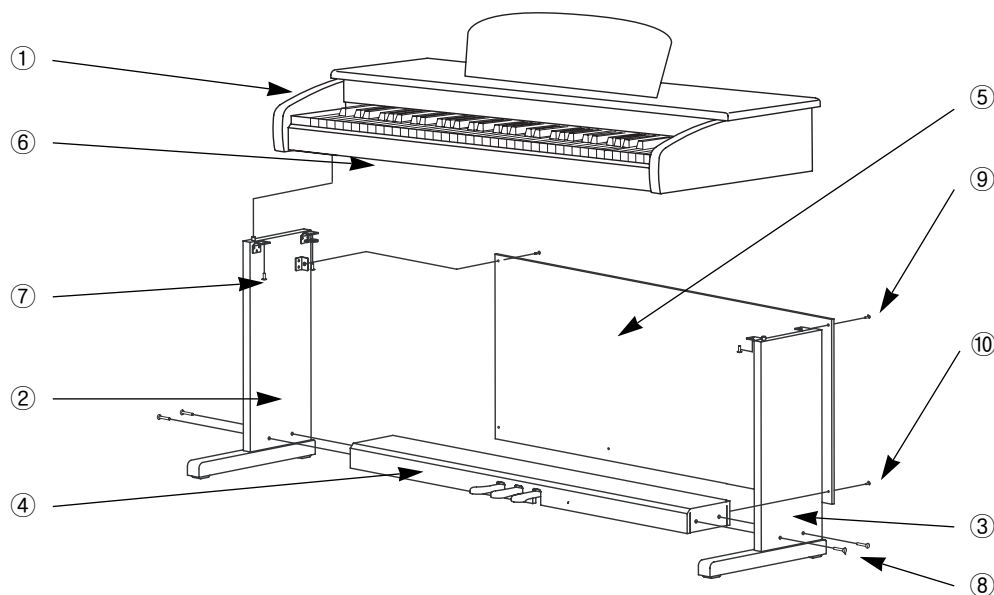



- We do not recommend attempting to assemble the RE-110 alone. The job can be easily accomplished, however, with only two people.
- Use only the screws provided or replacement of exactly the specified size. Using screws of the wrong size can result in damage to the instrument and personal injury.

Side Panel and Pedal Box assembly

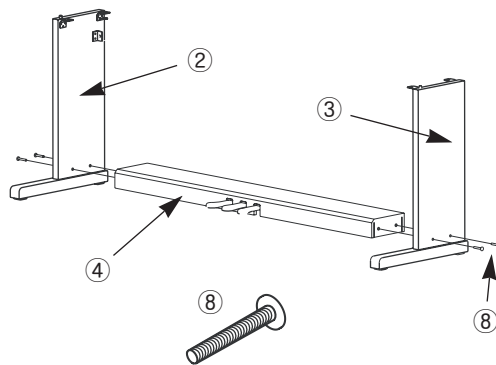

1. Place the pedal box ④ on the side panel ③ and then use ⑧ screws to fasten the side panel.
2. Place the Pedal Box ④ on the side panel ② and then use ⑧ screws to fasten the side panel.
3. You can find the pedal cable in the pedal box ④. Untie and straighten out the cable attached to the bottom of the pedal box.

Rear Panel assembly

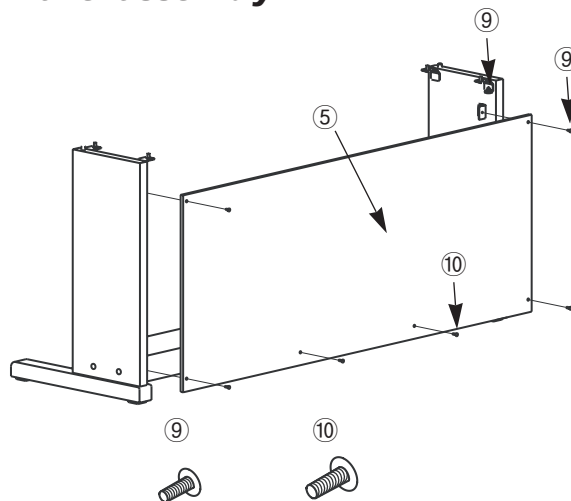

1. Fit into the holes ⑨ in the side panel brackets and then use the screw ⑨ to fasten the rear panel.
2. Use the screw ⑩ to fasten the bottom of the rear panel.

Attach the Keyboard

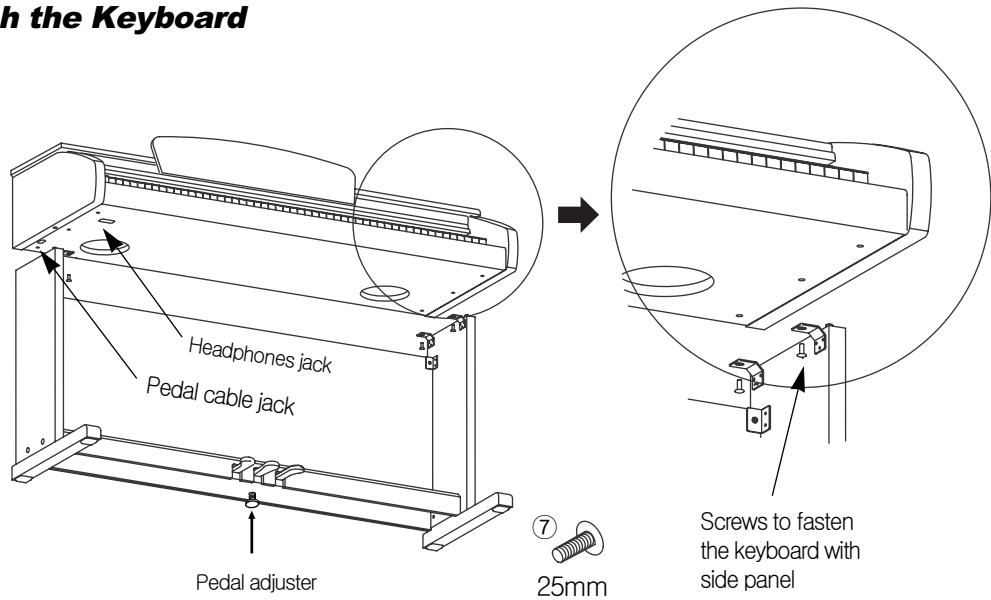

1. Place the keyboard on the stand so that the wood pegs on the bottom of the keyboard fit into the holes in the side panel brackets.
2. Fasten the keyboard to the side panel using screw number ⑦.
3. Insert the pedal cable connector into the pedal jack located on the bottom of the keyboard.

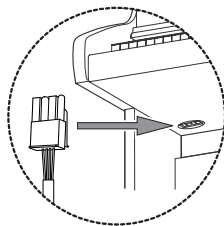

Be sure that the connector is inserted in the correct orientation.
Make sure that the cable clamp fastens to the pedal cable.

4. Rotate the pedal adjuster until it comes in firm contact with the floor surface. If the adjuster is not in firm contact with the floor, the pedal will wobble and cause malfunctions.
5. Install the headphone hanger as shown in the figure.

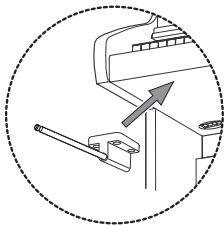

Turning on the Instrument (Power)

The RE-110 operates on AC adapter power. A power cord is included with the AC adapter to connect it to an AC outlet. Before connecting the power cord, be sure that the power switch, located left side of the keyboard, is off. First plug the adapter's small, round plug in the matching jack in the back of the piano. Then plug the power cord into an AC outlet. Once the power cord is connected, you can turn the power switch on.

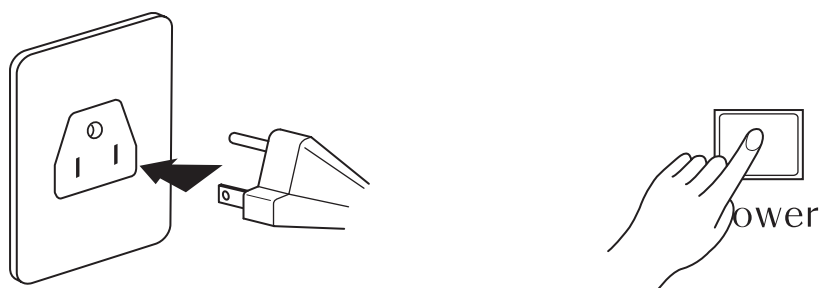

(The shape of plug differs depending on locale).

Setting the Volume

To be sure that you can hear the instrument, turn the Volume knob (on the upper side of the left panel) to the middle of its range. This should be a reasonably comfortable level of volume which you can adjust if you wish the sound to be louder or softer.

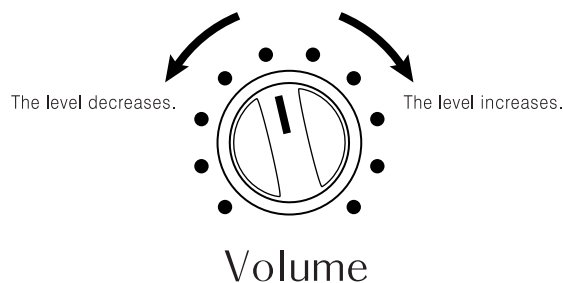



VOICE Button

Please refer to the Voice Button section of the Quick Operation Guide on page 27 while reading the following sections.

MAIN VOICE

To select one of the 10 primary voices, hold down the **Voice** button then press and release a keyboard key between C1 and A1. Then release the **Voice** button. For example, to select Digital E. Piano, hold down **Voice**, press and release the E1 key, then release **Voice**. Now when you play the keys you should hear the Digital E. Piano voice.

To select any of the 32 available voices, hold down the **Voice** button then "enter" the voice's number (1~32) by pressing the number keys (C2~A2) then press the "Enter" key (A#2), then release **Voice**. For example, to select Voice #23 (Ballad Organ 1), hold down **Voice**, press and release D2 (2), press and release D#2 (3), press and release A#3 (Enter), then release **Voice**. For voice numbers between 1 and 9, you need only press one number key.

If you get confused, just release the **Voice** button for a second then try again from the beginning.

For your reference, below is a list of the available voices, their number, and for the primary voices, their key.

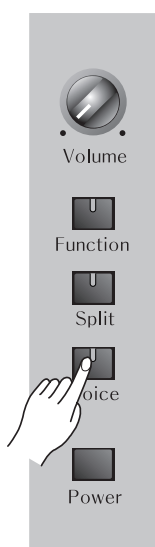
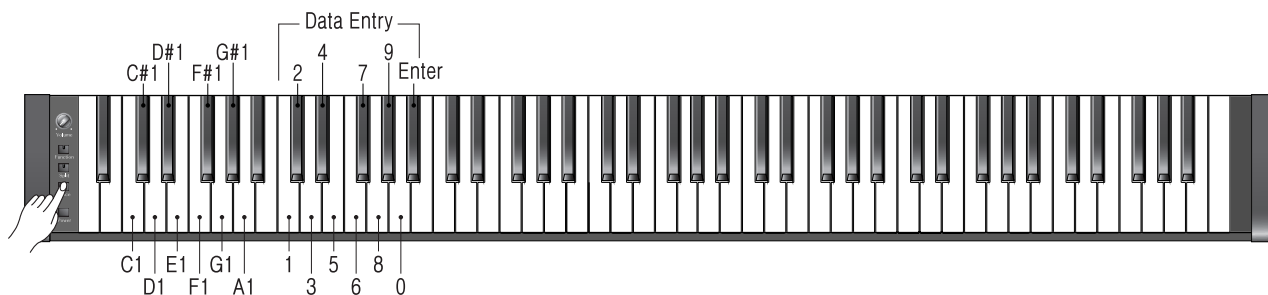

No	Key	Voice	No	Key	Voice
1	C1	Grand Piano 1 (Default)	17		Tremolo Digital E. Piano
2		Grand Piano 2	18		Stereo Hard E. Piano
3	C#1	Stage Piano 1	19	E1	Digital E. Piano
4		Stage Piano 2	20	G#1	Digital E. Piano + Strings Pad
5		Bright Piano	21	F1	Rock Organ 1
6		Sustain Piano	22		Rock Organ 2
7	D1	Stage Piano + Strings	23		Ballad Organ 1
8		Piano + Strings Pad	24		Ballad Organ 2
9		Tack Piano	25	F#1	Perc Organ
10		Tight E. Grand	26		Organ + Piano
11		Bright E. Grand	27	G1	Fast Strings 1
12		Warm E. Grand	28		Fast Strings 2
13		Classic E. Grand	29		Touch Strings
14		Digital E. Grand	30	A1	Stereo Slow Strings
15	D#1	Dyno E. Piano	31		Stereo Slow Strings Pad
16		Hard Dyno E. Piano	32		Slow Digital Pad

REVERB & CHORUS

Reverb

While holding down the **Voice** button, press one of the C3 ~ E3 keys to select a reverb type. If you select Effect Off (E3 key), both reverb and chorus will be turned off.

Key	Reverb Type
C3	Room (with Chorus)(Default)
C#3	Stage(with Chorus)
D3	Hall (with Chorus)
D#3	Large Hall (with Chorus)
E3	Effect Off

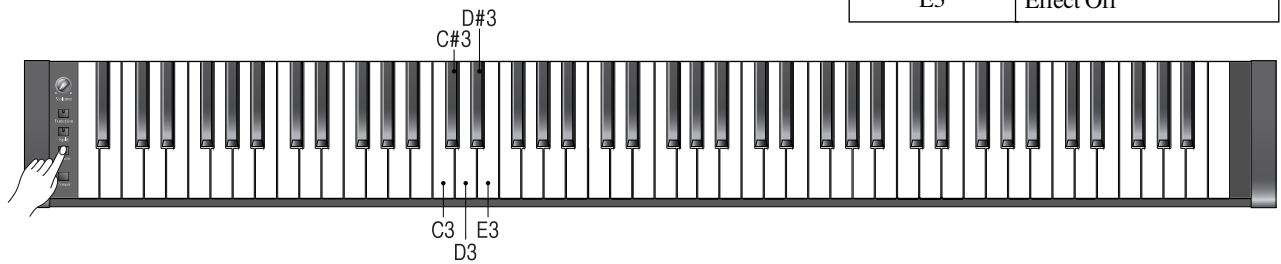

Reverb Wet/Dry Mix

"Wet/dry mix" is a term that describes how loud the effect sound (wet sound = reverberation or chorus) is compared to the direct sound (dry sound = played notes). A ratio of 10% for example will be mostly direct sound with very little effect sound. A ratio of 50% will be about half and half while 90% will be nearly all effect sound.

Adjust the reverb wet/dry amount for the selected reverb type by pressing one of the C4 ~ A#4 keys while holding down the **Voice** button. The wet/dry mix range is from 0 to 100%. The default reverb type and wet/dry amount are Room and 10% respectively.

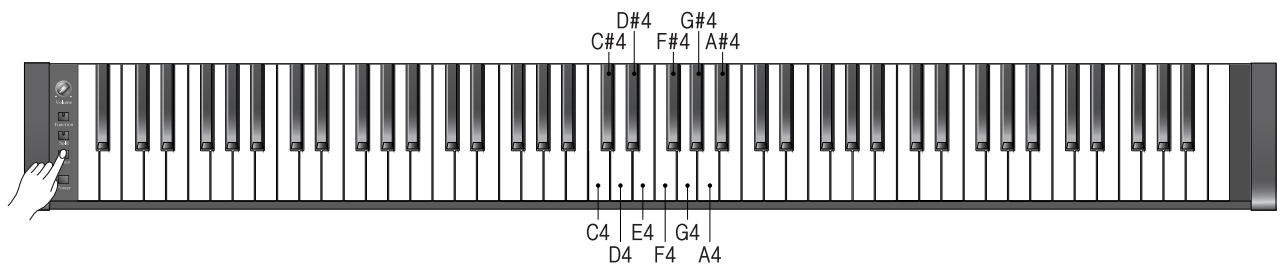

Key	Reverb Wet/Dry	Key	Chorus Wet/Dry
C4	0	C5	0 (Default)
C#4	10 (Default)	C#5	10
D4	20	D5	20
D#4	30	D#5	30
E4	40	E5	40
F4	50	F5	50
F#4	60	F#5	60
G4	70	G5	70
G#4	80	G#5	80
A4	90	A5	90
A#4	100	A#5	100

Chorus Wet/Dry Mix

While holding down the **Voice** button, press one of the C5 ~ A#5 keys to select the chorus wet/dry amount. The default wet/dry amount for chorus is 0%. If you select Effect Off for the reverb type, then the chorus effect will also be turned off and you will only hear the direct sound.

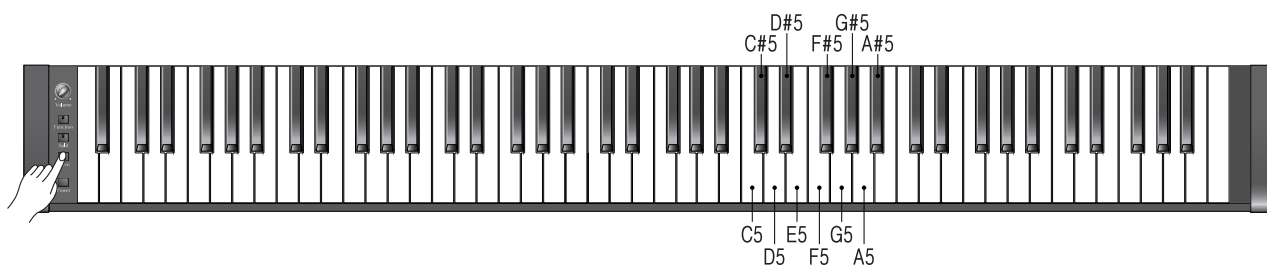

DEMO SONG

While holding down the **Voice** button, press one of the C6 ~ F6 keys to select and play a demo song. If you want all demo songs to be played in a loop, press the F6 key. While playing the demo, the **Voice** LED is blinking. To stop the demo song playback, press the **Voice** button again.

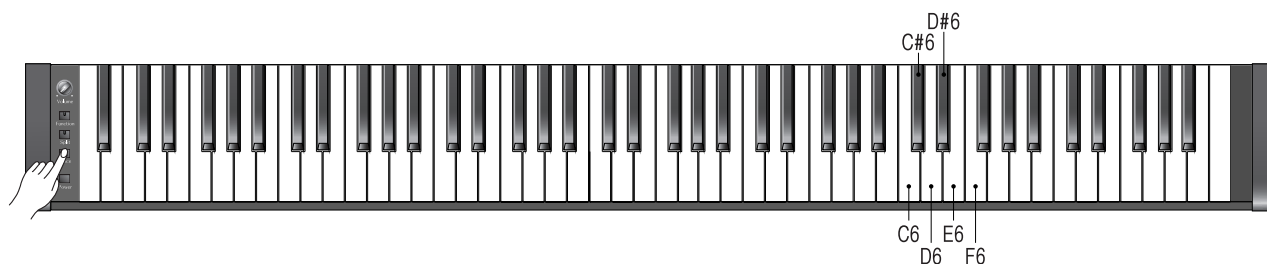

Key	Demo Song		
C6	Demo 1	Witches Dance	Macdowell
C#6	Demo 2	Arabesque	Debussy
D6	Demo 3	French Suite No 5	Bach
D#6	Demo 4	Capriccio in B Op76 No 2	Brahms
E6	Demo 5	Oriental	Granados
F6	Repeat All (Demo 1 ~ Demo 5)		



SPLIT Button

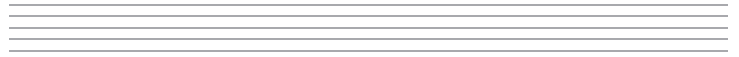

Press the **Split** button to activate split mode. The **Split** button indicator will light.

Splits are an easy way to make one performer sound like two. When you play the keyboard, your right hand plays one voice and your left hand plays another. To exit split mode, press the **Voice** button.

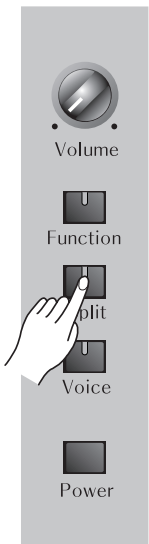

SPLIT POINT

While holding down the **Split** and **Function** buttons simultaneously, press any key of the keyboard to set the split point. The split point is the point on the keyboard where the left sound and right sound meet. The default split point set at the factory is F#3.

LOWER VOICE

The Lower Voice is the Left Sound as described above. To select one of the 10 primary voices as the lower voice, hold down the **Split** button then press and release a keyboard key between C1 and A1. To select any of 32 available voices as the lower voice, hold down the **Split** button then "enter" the voice's number (1~32) by pressing the number keys (C2~A2) then press the "Enter" key (A#2), then release **Split**. See Page 12 for the voice list.

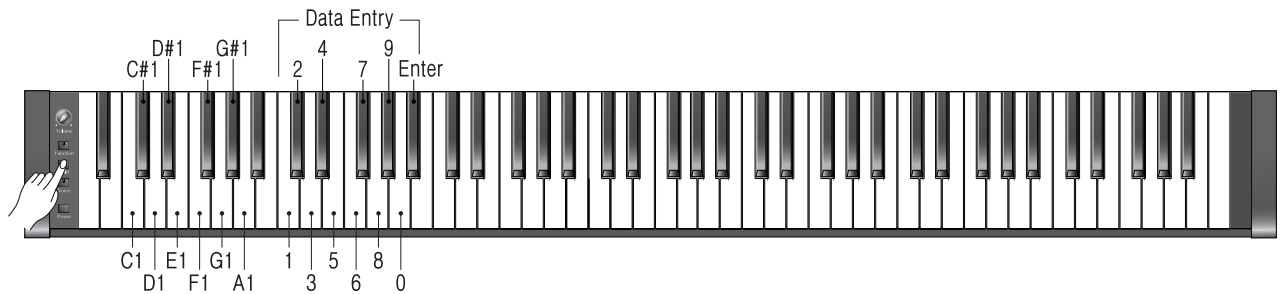

UPPER VOICE

The upper voice in Split Mode is the same as the main voice. It's not necessary to select the upper voice separately.

LOWER OCTAVE SHIFT

You can shift the left sound pitch up one or two octaves if you wish. To do this, press and hold the **Split** button then press C#3 for a one octave shift, D3 for two octaves, or C3 to restore normal pitch.

Key	Lower Octave
C3	0 (Default)
C#3	+1
D3	+2

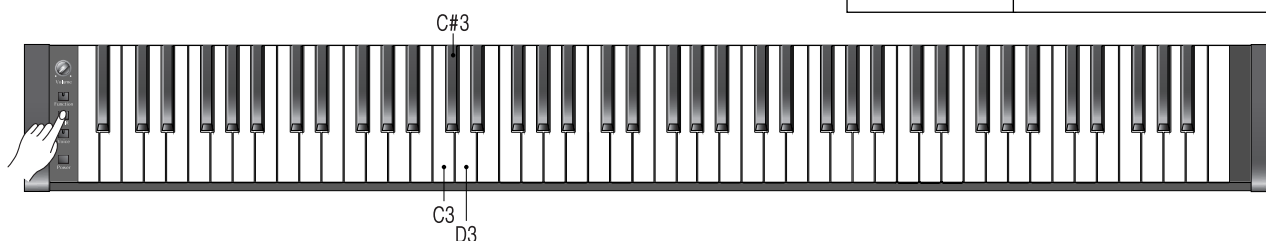

UPPER OCTAVE SHIFT

You can shift the right sound pitch down one or two octaves if you wish. To do this, press and hold the **Split** button then press F#3 for a one octave shift, F3 for two octaves, or G3 to restore normal pitch.

Key	Upper Octave
F3	-2
F#3	-1
G3	0 (Default)

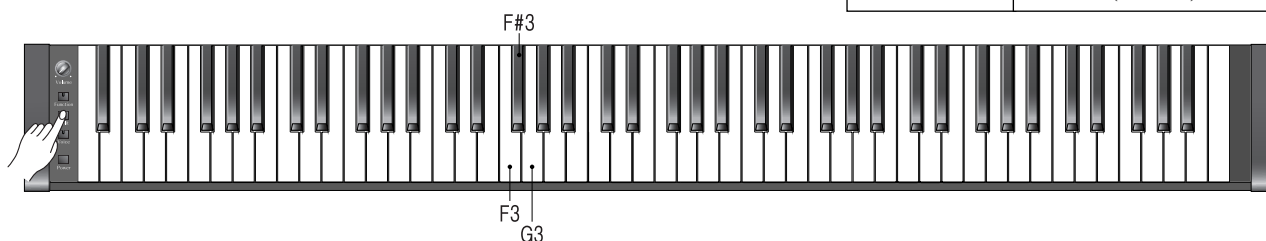

4-HAND SETUP

The 4-hand setup makes it easy to set the Split Point and Octave Shifts for 2-person (4-hand) playing. To enable 4-Hand Setup, press and hold **Split** then press and release the C4 (Middle C) key. This will set the upper and lower voice, the split point, and octave shifts as shown below. If any of these defaults are not suitable, they can be changed using the methods described earlier.

Key	4-Hand Setup	
C4	Lower Voice	Grand Piano 1
	Upper Voice	Grand Piano 1
	Split Point	C4
	Lower Octave	+2
	Upper Octave	-2

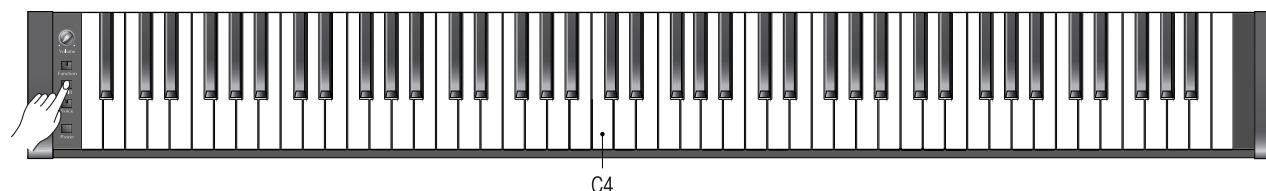



FUNCTION Button

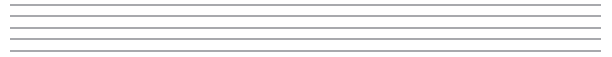

TOUCH

You can adjust the touch sensitivity of the entire keyboard - how the dynamics of the sounds respond to key velocity.

While holding down the **Function** button, press one of the C1 ~ E1 keys to select the touch sensitivity.

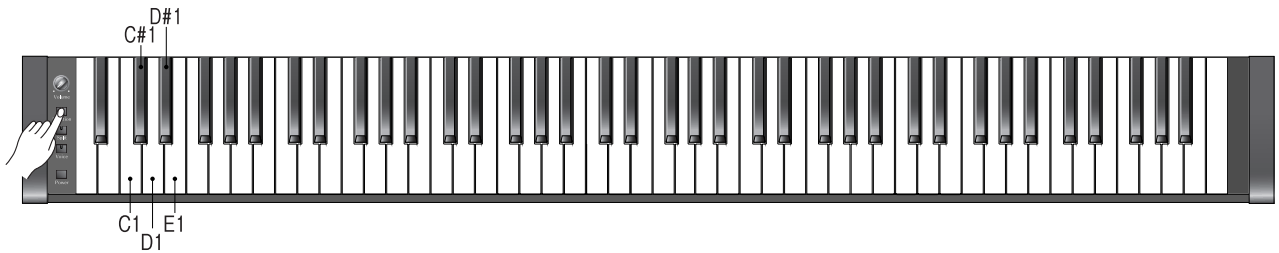

Key	Touch	
C1	Light 1	For players who have a light touch-that is, you can play more lightly and still get the same attack velocity values. Light 2 is a bit more sensitive than Normal, Light 1 is the most sensitive.
C#1	Light 2	
D1	Normal (Default)	The standard value
D#1	Hard 1	For players who have a heavier touch-that is, you can play harder and still get the same attack velocity values. Hard 1 is less sensitive than Normal, Hard 2 is the least sensitive.
E1	Hard 2	

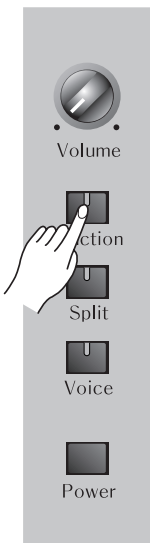

TUNE

You can finely tune the pitch of the RE-110 up or down. This function is useful when you play the RE-110 along with other instruments that can't be easily retuned.

While holding down the **Function** button, press the C#2 or D#2 key to adjust the pitch by steps of 1 cent. The C2 or E2 key adjust the pitch in steps of 5 cents. The tuning range is 64 cents flat to 64 cents sharp.

Key	Tune Value
C2	-5 (Step)
C#2	-1 (Step)
D2	0 (440Hz-Default)
D#2	+1 (Step)
E2	+5 (Step)

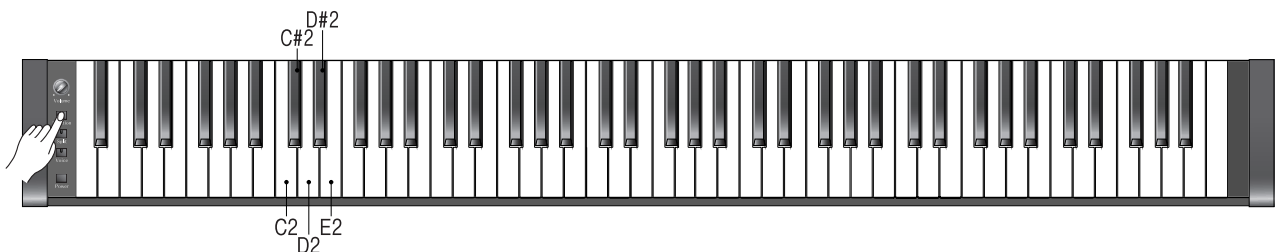

TRANPOSE

Transpose allows you to play the keyboard in one key and have the notes sound in another key. This is useful when accompanying singing, if the key of the written music is too high or too low for the singer, or when playing music written for a transposing instrument, such as a clarinet. The transpose function makes it possible to shift the pitch of the entire keyboard up or down in semitone intervals up to six semitones.

While holding down the **Function** button, press one of the F#2 ~ F#3 keys to set the desired amount of transposition.

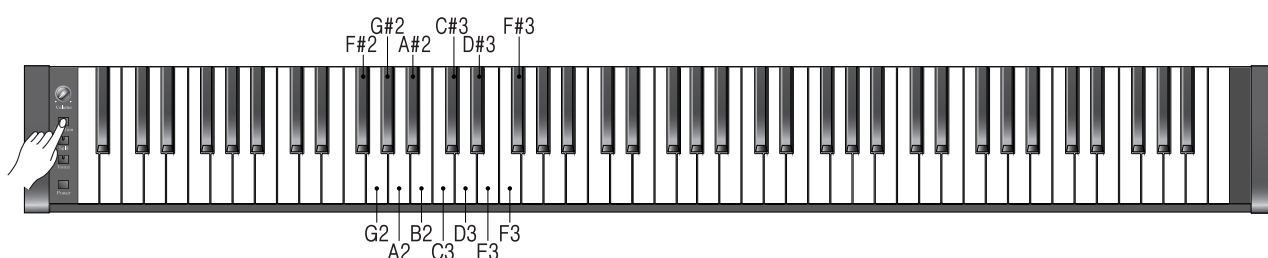

Key	Transpose Value	Key	Transpose Value
F#2	-6	C#3	+1
G2	-5	D3	+2
G#2	-4	D#3	+3
A2	-3	E3	+4
A#2	-2	F3	+5
B2	-1	F#3	+6
C3	0 (Default)		

MIDI RECEIVE AND TRANSMIT CHANNEL

The MIDI channels of the receiving and transmitting equipment must be matched for proper data transfer. This function enables you to specify the channel on which the RE-110 transmit and receives MIDI data.

While holding down the **Function** button, press one of the C4 ~ D#5 keys to set the desired MIDI receive channel. And press one of the C6 ~ D#7 keys to set the desired MIDI transmit channel. See Page 22 for more about your RE-110's MIDI features.

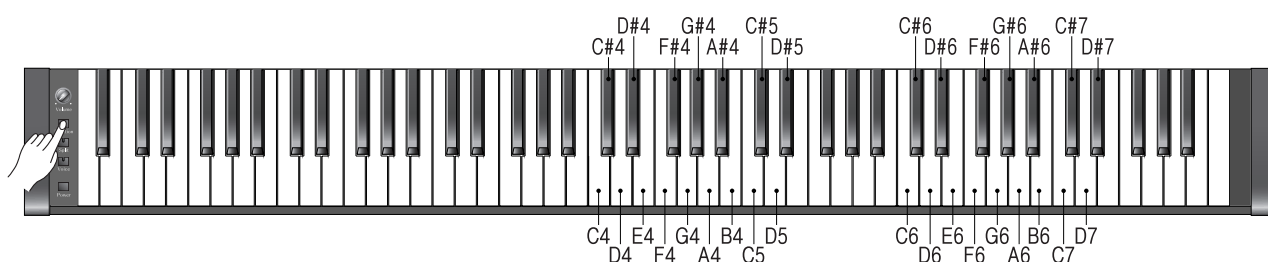

Key	Receive Channel	Key	Transmit Channel
C4	Ch 1 (Default)	C6	Ch 1 (Default)
C#4	Ch 2	C#6	Ch 2
D4	Ch 3	D6	Ch 3
D#4	Ch 4	D#6	Ch 4
E4	Ch 5	E6	Ch 5
F4	Ch 6	F6	Ch 6
F#4	Ch 7	F#6	Ch 7
G4	Ch 8	G6	Ch 8
G#4	Ch 9	G#6	Ch 9
A4	Ch 10	A6	Ch 10
A#4	Ch 11	A#6	Ch 11
B4	Ch 12	B6	Ch 12
C5	Ch 13	C7	Ch 13
C#5	Ch 14	C#7	Ch 14
D5	Ch 15	D7	Ch 15
D#5	Ch 16	D#7	Ch 16

Notes transmitted are the actual keyboard keys pressed irrespective of splitting, transposition, and octave shift. Notes received are treated just like keypresses and may be modified by the current split, transpose, and octave shift settings.

Program Changes received will only affect the current Upper Voice if the keyboard split is active.

LOCAL CONTROL

Local Control is the connection between the keyboard of the RE-110 and the internal sound-producing circuitry of the instrument. Normally, Local Control is ON; in fact, every time you power-up the RE-110, it automatically sets to Local Control ON, so you can play the keyboard and hear the sounds of the instrument. But, there are reasons for setting Local Control to OFF especially when MIDI Out of the RE-110 is connected to feed back to the instrument's MIDI In port. One example of this is when using an external sequencer whose MIDI In port is connected to MIDI Out of the RE-110 and whose MIDI Out port is connected to MIDI In of the RE-110. In such a case, you can eliminate the doubling of notes by setting Local Control to OFF.

While holding down the **Function** button, press the key G7 or A7 to set Local Control. See Page 22 for more about your RE-110's MIDI features

Key	Local Control
G7	ON(Default)
A7	OFF

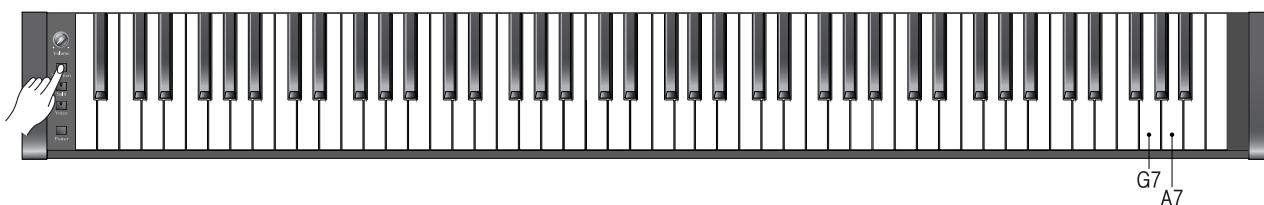

RESET

Since the RE-110 does not have a display, it is hard to know the current settings. If you get confused or want to restore the default settings, just hold down the **Function** button then press and release the C8 key. After doing this, all of the settings will be reset as the table below.

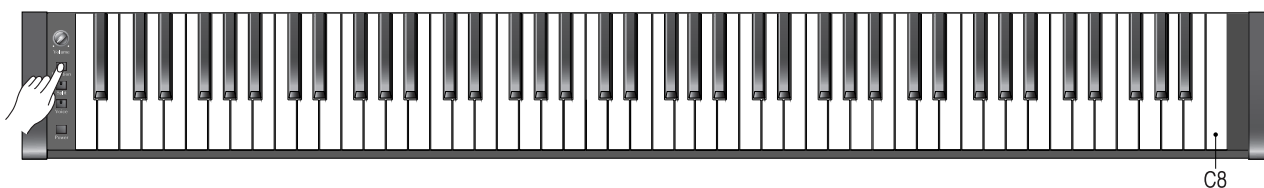

Key	Reset Value	
C8	Voice	Grand Piano 1
	Reverb Type	Room
	Reverb Wet/Dry	10
	Chorus Wet/Dry	0
	Upper Voice	Grand Piano 1
	Lower Voice	Fast Strings 1
	Split Point	F#3
	Upper Octave	0
	Lower Octave	0
	Touch	Normal
	Tune	0 (440Hz)
	Transpose	0
	MIDI Receive Channel	1
	MIDI Transmit Channel	1
Local Control	On	



PEDALS

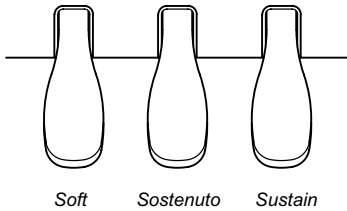
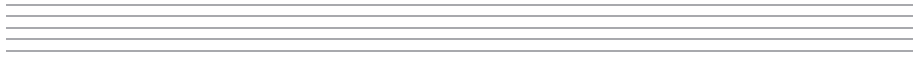

SUSTAIN PEDAL

The sustain pedal (rightmost pedal) functions in the same way as the damper pedal of an acoustic piano. When the sustain pedal is pressed, notes continue to play after their keys have been released. Releasing the pedal will silence the sustained notes.

SOSTENUTO PEDAL

If you play a note on the keyboard and press the sostenuto pedal while the notes are held, those notes will still sustain as long as you hold the pedal. But all subsequently played notes will not be sustained.

SOFT PEDAL

The soft pedal reduces the volume while the pedal is pressed. The soft pedal will not affect notes that are already playing when it pressed.



MIDI

"MIDI" stands for "Musical Instrument Digital Interface." It is an international standard that allows electronic musical instruments to communicate with each other, using a simple cable connection. It ensures that the RE-110 will remain compatible with the instruments of today and tomorrow.

MIDI Connection

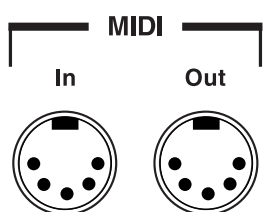

On the rear panel are two MIDI ports:

- MIDI In receives MIDI messages **from** other equipment.
- MIDI Out sends MIDI messages **to** other equipment.

MIDI cables provide the connection between the MIDI ports of one piece of equipment and those of another. To keep things simple, there are only two valid MIDI connections: Out to In, In to Out.

The simplest use of MIDI is to play two instruments at a time from the keyboard of one of them. This is known as a "Master-Slave" connection. Use a MIDI cable to connect the MIDI Out port of the "Master" (the instrument whose keyboard you'll play) to the MIDI In port of the "Slave".

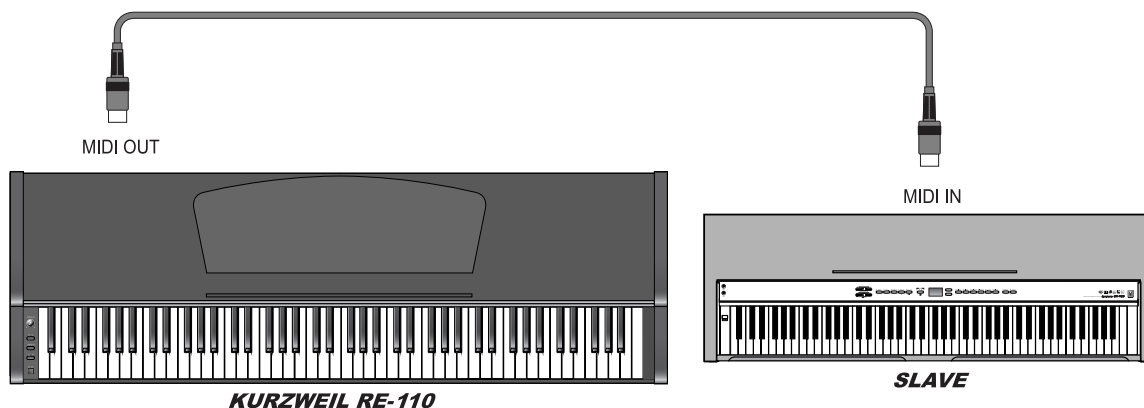

If you connect In to Out, rather than Out to In, the other instrument becomes the Master. And if you use two cables, connecting In to Out, Out to In, you can use either instrument as the Master.

You probably will want to use the RE-110 as your master keyboard. It is important to explain that what is sent over the MIDI cables is information (data), not sound. In fact, the usefulness of the master-slave setup lies in having each instrument produce a different sound, resulting in a layering of sounds that expands on the layering that is possible with the RE-110 itself.

The slave can be a MIDI organ, portable keyboard, synthesizer, tone module, drum machine, or effects device. If it doesn't have built-in amplification and speakers, connect its audio output to the RE-110 Audio In jacks on the RE-110 rear panel.

Another application of MIDI is in using a sequencer to record and play back your performance. An external sequencer can be a special hardware unit designed for that purpose, or it can be a PC running special sequencing software. In either use, the MIDI connections are the same - Out to In, In to Out.

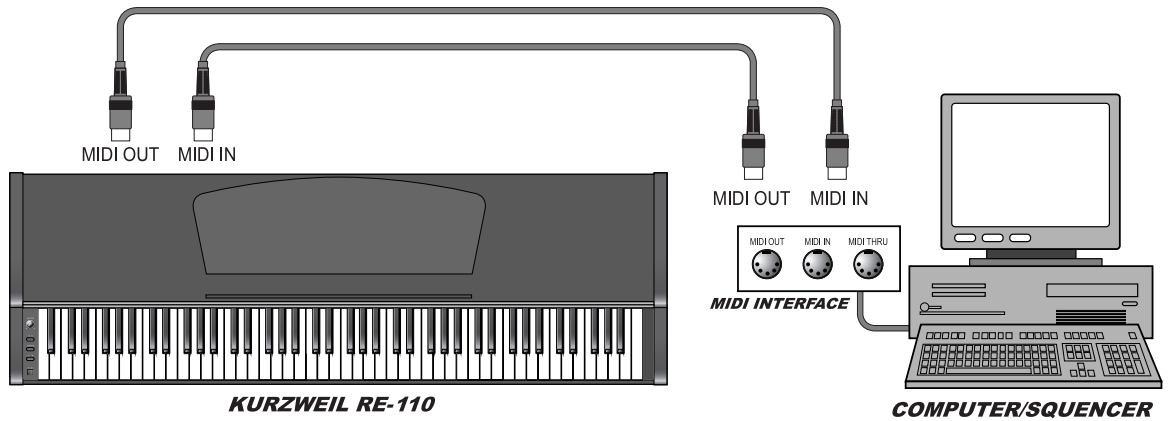

MIDI Channels

For MIDI to control several instruments, each playing a different part at the same time, it relies on different **channels**. MIDI channels are like TV channels: an instrument has to be "tuned" to the correct one or it won't receive what is being transmitted. There are 16 channels available, and each one can transmit any number of notes to any number of instruments, over the same MIDI cable.



Miscellaneous

HEADPHONES

A headphone jack allows private practice. Plugging in a pair of headphones turns off the speakers. You can also insert a "dummy" stereo headphone adapter. This is useful if you want to mute the internal speaker system while using a more powerful external amplification system connected to Audio out jack. There are two identical headphone jacks on the RE-110.

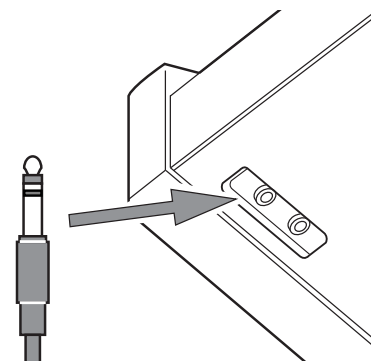

AUDIO IN JACK

The Audio In jacks allow you to play along with a tape, CD player or to have an external tone module connected to the RE-110 audio system. It is best to use a tone module, tape or CD player that has its own output volume control because the volume control of the RE-110 does not affect the signal coming from the Audio In jacks.

AUDIO OUT JACK

The Audio Out jack is used to boost the sound level coming from the piano by hooking it to external amplifier and speaker systems. It can also be connected to an audio recorder to preserve your performance. The RE-110's volume control also affects the signal at the Audio Out jacks. If you wish to silence the RE-110's speakers while using the Audio Out jacks, plug a pair of headphones into either Headphone jack.

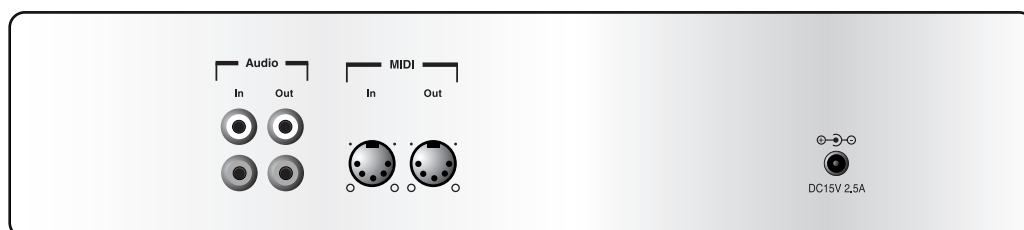

MIDI Implementation Chart

Manufacturer : KURZWEIL
 Model : RE-110 Digital Piano

Date : 2/1/2006
 Version 1.0

Function	Transmitted	Recognized	Remarks	
Basic Channel	Default	1	1	
	Changed	1-16	1-16	
Mode	Default		Poly	
	Messages	Any	Mode 3	
	Altered	X		
Note Number	Key range	0 - 127	12 - 108	
	True Voice	0 - 127	12 - 108	
Velocity	Note ON	O	O	
	Note OFF	O	O	
After Touch	Keys	X	X	
	Channels	X	X	
Pitch Bender		X	X	
Control Change	0, 32	X	X	Bank Select
	1	X	O	Mod Wheel
	6	X	X	Data Entry
	7	X	O	Volume
	10	X	X	Pan
	11	X	X	Expression
	64	O	O	Sustain Pedal
	66	O	O	Sostenuto Pedal
	67	O	O	Soft Pedal
	83	X	O	Reverb Select
	91	O	O	Reverb Wet/Dry
	93	O	O	Chorus Wet/Dry
	120	X	X	All Sound Off
121	X	O	Reset All Controllers	
Program Change		O 1 - 32	O 1 - 32	
	True #	O 0 - 31	O 0 - 31	
System Exclusive		X	X	
System Common	Song Pos.	X	X	
	Song Sel.	X	X	
	Tune	X	X	
System Real Time	Clock	X	X	
	Messages	X	X	
Aux Messages	Local Control	X	X	
	All Notes Off	O	O	
	Active Sense	X	X	
	Reset	X	X	

Notes

Mode 1 : Omni On, Poly
 Mode 3 : Omni Off, Poly

Mode 2 : Omni On, Mono
 Mode 4 : Omni Off, Mono

O = Yes
 X = No



Appendix

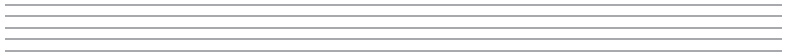

Specification

Physical

Height	32.3 inch	82 cm
Depth	16.5 inch	42 cm
Length	54.3 inch	138 cm
Weight	112 lbs	51 kg

Audio

25 Watt Amplification	2 x 12.5 Watts RMS Per Channel
2 Speakers	4 x 6 inch (10cm x 15cm) Oval Type
Audio Outputs	Impedance : 1K Ω source Level : nominal 0.5V RMS
Audio Inputs	Impedance : 50K Load Level : nominal 0.5V RMS
Headphone Output	Impedance : 47 Ω source Level : nominal 0.5V RMS

Electrical

Safe Voltage Range	90~125 Volts or 190~250 Volts depending on adapter
Safe Frequency Range	47 ~ 63Hz
Power Consumption	20 Watts nominal (Piano sound at normal volume)

Environmental

Operating Temperature	5 to 40 $^{\circ}$ C	(40 to 104 $^{\circ}$ F)
Storage Temperature	-25 to +85 $^{\circ}$ C	(-13 to 185 $^{\circ}$ F)
Operating Humidity	5 to 95% (non ~ condensing)	
Storage Humidity	5 to 95% (non ~ condensing)	



Quick Operation Guide

While holding down the **Voice, Split** or **Function** button, press the keys shown below to select voices, split voices or functions.

Function

Split

Voice

Touch	Lower Voice	Voice & Upper Voice	A0
Light 1	Grand piano 1	Grand piano 1	A#0
Light 2	Stage piano 1	Stage piano 1	B0
Hard 1	Piano+String	Piano+String	C1
Hard 2	Dyno E. Piano	Dyno E. Piano	C#1
	Digital Piano	Digital Piano	D1
	Rock Organ 1	Rock Organ 1	D#1
	Perc Organ	Perc Organ	E1
	Fast String 1	Fast String 1	F1
	E. Piano + Str Pad	E. Piano + Str Pad	F#1
	Slow String	Slow String	G1
			G#1
			A1
			A#1
			B1
			C2
			C#2
			D2
			D#2
			E2
			F2
			F#2
			G2
			G#2
			A2
			A#2
			B2
			C3
			C#3
			D3
			D#3
			E3
			F3
			F#3
			G3
			G#3
			A3
			A#3
			B3
			C4
			C#4
			D4
			D#4
			E4
			F4
			F#4
			G4
			G#4
			A4
			A#4
			B4
			C5
			C#5
			D5
			D#5
			E5
			F5
			F#5
			G5
			G#5
			A5
			A#5
			B5
			C6
			C#6
			D6
			D#6
			E6
			F6
			F#6
			G6
			G#6
			A6
			A#6
			B6
			C7
			C#7
			D7
			D#7
			E7
			F7
			F#7
			G7
			G#7
			A7
			A#7
			B7
			C8

Reverb

- 0 Effect Off
- Room
- Hall
- Stage
- Large Hall

Reverb Wet/Dry

- 0
- 10
- 20
- 30
- 40
- 50
- 60
- 70
- 80
- 90
- 100

Chorus Wet/Dry

- 0
- 10
- 20
- 30
- 40
- 50
- 60
- 70
- 80
- 90
- 100

Demo song

- Repeat All
- Demo 5
- Demo 4
- Demo 3
- Demo 2
- Demo 1

Lower [Octave]

- 0
- +1
- +2

Upper [Octave]

- 0
- 1
- 2

Data Entry

- 0 Enter
- 1
- 2
- 3
- 4
- 5
- 6
- 7
- 8
- 9

Transpose

- 6
- 5
- 4
- 3
- 2
- 1
- 0
- +1
- +2
- +3
- +4
- +5
- +6

Tune

- 5
- 1
- 0 (440Hz)
- +1
- +5

MIDI Receive Channel

- Channel 1
- Channel 2
- Channel 3
- Channel 4
- Channel 5
- Channel 6
- Channel 7
- Channel 8
- Channel 9
- Channel 10
- Channel 11
- Channel 12
- Channel 13
- Channel 14
- Channel 15
- Channel 16

MIDI Transmitt Channel

- Channel 1
- Channel 2
- Channel 3
- Channel 4
- Channel 5
- Channel 6
- Channel 7
- Channel 8
- Channel 9
- Channel 10
- Channel 11
- Channel 12
- Channel 13
- Channel 14
- Channel 15
- Channel 16

Local

- On
- Off

Reset

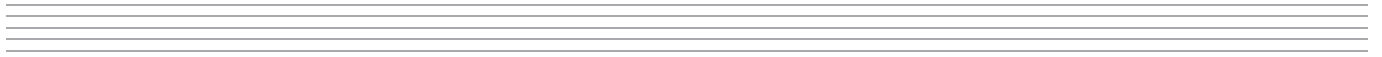

Notes



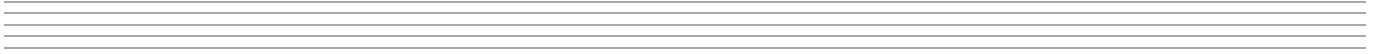

Notes



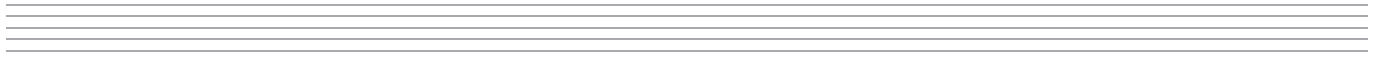

Notes



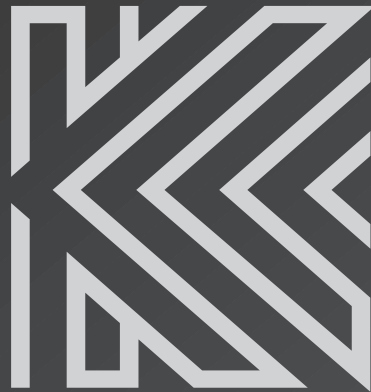

KURZWEIL

Music Systems

www.ycpiano.co.kr
www.kurzweilmusicsystems.com